



SLIM

Wired Intercom System

- Wired audio intercom system.
- Up to 4 handsets per system.
- Curved profile stylish handset available in black.
- 150m typical cabled range using twisted pair cables.
- 24V dc 2A power supply included. (Handsets 12v dc)

Indoor Speech Unit

Outdoor Speech Unit

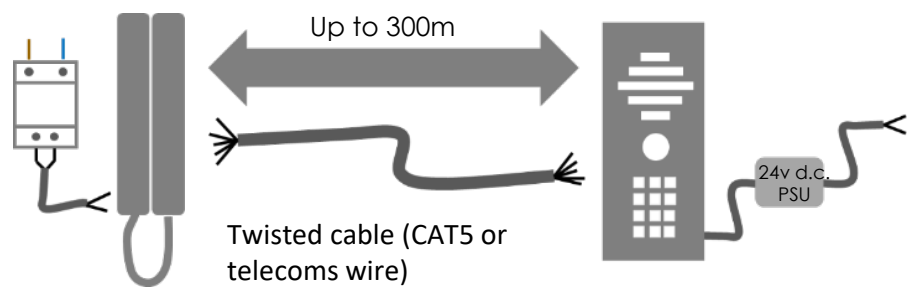

Technical Details

| | |
|-------------------------|------------------------------|
| Power | 24v dc (24c dc 2A included) |
| Working Distance | 150m on 24AWG CAT5 cable |
| Weather Rating | IP55 |
| Wiring | 3 Wire or 5 wire option |
| Max Handsets | 4 |
| Relay Type | N/O momentary 4 second pulse |



SLIM-CL-AB (Architectural Model)



SLIM-HF-AB (Architectural Model)



- Stylish curved architectural model, featuring modern blue back lighting effect, constructed from BS316 marine grade, brushed stainless steel with gloss acrylic trim.
- Kit includes speech panel, **black** handset, power supply and manual.

SLIM-CL-AS (Architectural Model)



SLIM-HF-AS (Architectural Model)



- Stylish curved architectural model, featuring contemporary white back lighting effect, constructed from BS316 marine grade, brushed stainless steel.
- Kit includes speech panel, **black** handset, power supply and manual.

SLIM-CL-IMP (Imperial Model)



SLIM-HF-IMP (Imperial Model)



- Ultra stylish hooded model. All black panel with textured powder coated aluminium hood and gloss black acrylic facia trim over a tough metal back plate, with white illuminated push button.
- Kit includes speech panel, **black** handset, power supply and manual.



SLIM-CL-ABK (Architectural Keypad Model)



SLIM-HF-ABK (Architectural Keypad Model)



- Stylish curved architectural model, with built in illuminated code-lock keypad for access control.
- Keypad includes 3 relays with latching and momentary operation and many more features.
- BS316 marine grade, brushed stainless steel construction with gloss acrylic trim and blue back lighting effect.
- Kit includes speech panel, **black** handset, power supply and manual.

SLIM-CL-ASK (Architectural Keypad Model)



SLIM-HF-ASK (Architectural Keypad Model)



- Stylish curved architectural model with built in, illuminated code-lock keypad for access control.
- Keypad includes 3 relays, with latching and momentary operation and many more features.
- 100% BS316 marine grade stainless steel construction with contemporary cool-white back lighting.
- Kit includes speech panel, **black** handset, power supply and manual.

SLIM-CL-IMPCK (Imperial Model with Keypad)



SLIM-HF-IMPCK (Imperial Model with Keypad)



- Hooded model with built in illuminated code-lock keypad for access control.
- Keypad includes 3 relays, 1200 codes with latching and momentary operation and more.
- Stylish all black panel with textured powder coated aluminium hood and gloss black acrylic fascia trim over a tough metal back plate.
- Kit includes speech panel, **black** handset, power supply and manual.



Industrial Panel NON Keypad

SLIM-CL-IMP-PED (Industrial Model)



SLIM-HF-IMP-PED (Industrial Model)



- Industrial model for high volume applications on pedestals, vehicle entrances, etc.
- Super loud 4 watt speaker and sensitive microphone, with illuminated push button.
- Brushed stainless steel construction with gloss acrylic trim.
- Kit includes speech panel, **BLACK** handset, power supply and manual.

Industrial Panel with Keypad

SLIM-CL-IMPK-PED (Industrial Model with Keypad)



SLIM-HF-IMPK-PED (Industrial Model with Keypad)



- Industrial model for high volume applications on pedestals, vehicle entrances, etc.
- Super loud 4 watt speaker and sensitive microphone, with illuminated push button.
- Keypad includes 3 relays, 1200 codes with latching and momentary operation and more.
- Brushed stainless steel construction with gloss acrylic trim.
- Kit includes speech panel, **BLACK** handset, power supply and manual.

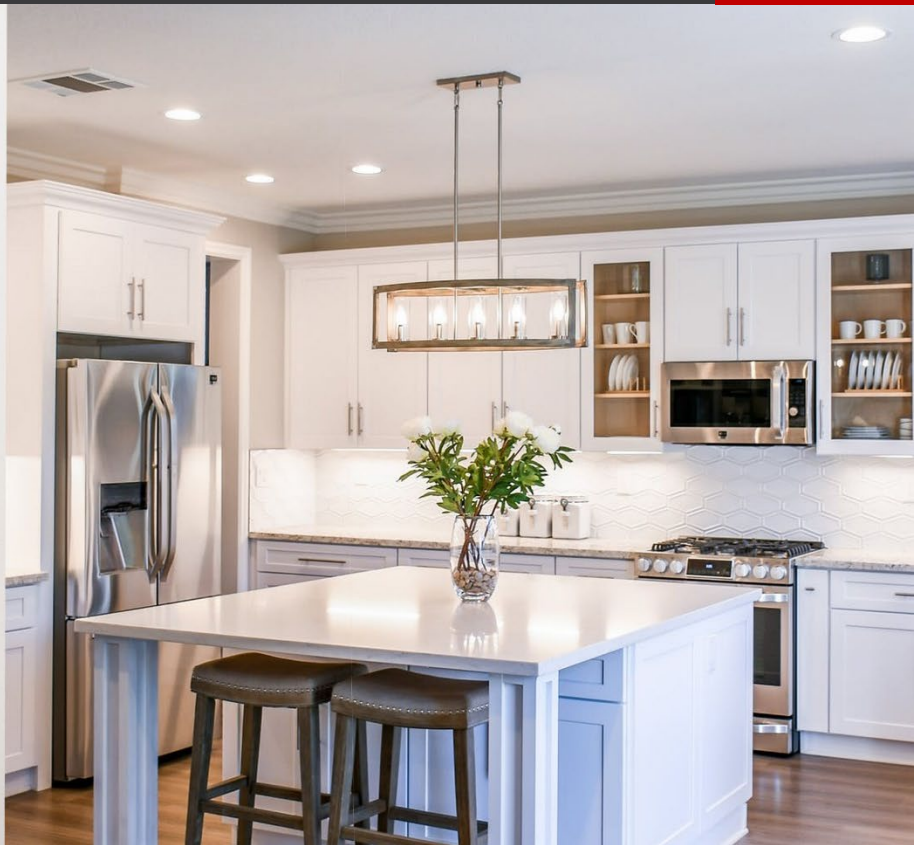

Black Handset



SLIM-CL-EH-B

- Black corded handset.
- Add up to 3 extra handsets to any kit (total 4 per system) for larger homes or premises.

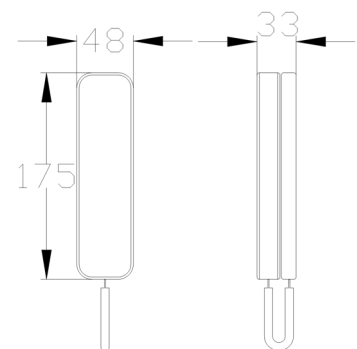

SLIM-HF-EH-B

- Black Handsfree handset.
- Add up to 3 extra handsets to any kit (total 4 per system) for larger homes or premises.

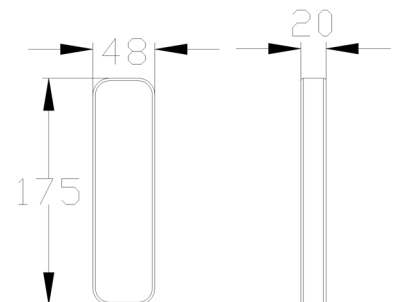



PSU-12V

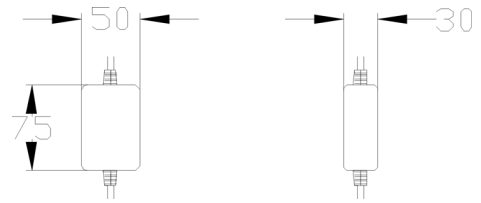

Additional 12V, 1 amp power supply for longer cable runs, especially required when call point has a keypad and the original PSU is located in the house or where there are multiple handsets.

Call Panel Dimensions

AB/AS PANEL

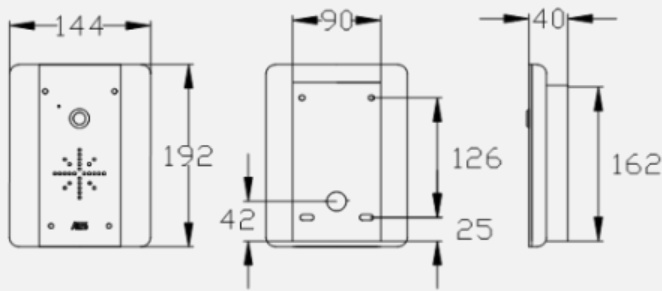

ABK/ASK PANEL

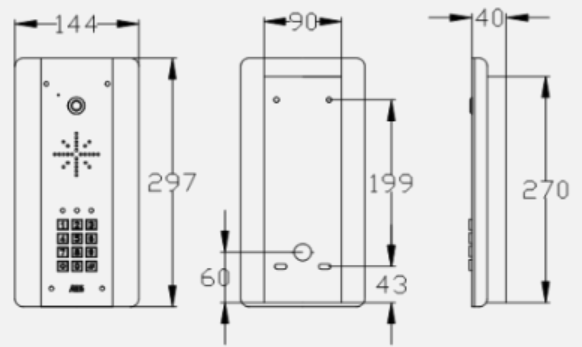

IMP PANEL

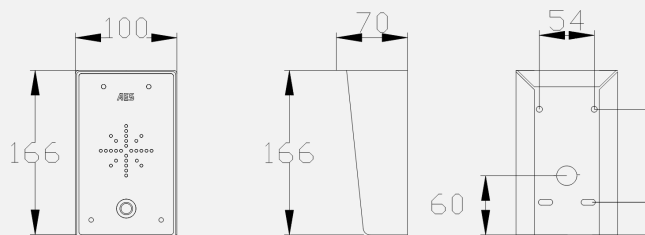

IMPK PANEL

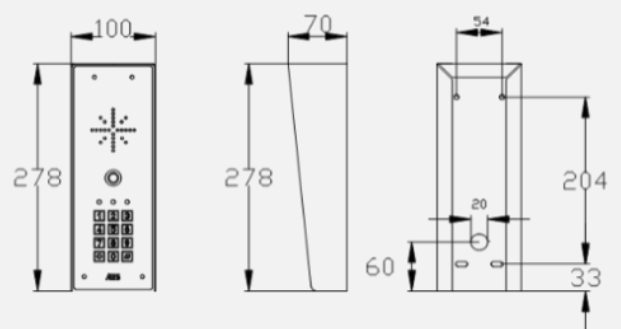

IMP-PED PANEL

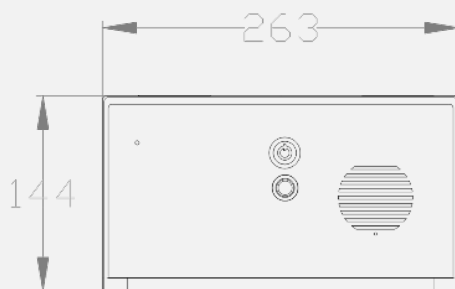

IMPK-PED PANEL

