

SURFACE FIXED DIGITAL GATE LOCK



SPECIFICATION SHEET

DGLW

A marine grade Digital Gatelock with many unique features.

G Auto-latching – close the gate and the latchbolt latches into the gate frame. To open the gate - enter the code and turn the handle.

G No power needed – High quality digital keypads ensure long lasting durability.

G Latchbolt is adjustable in length for precise fitting on site.



RIGHT HAND LOCK SHOWN

PRODUCT DETAILS

Product code: Description:

DGLWL	Left handed, double sided (keypad on both entry and exit side)
DGLWR	Right handed, double sided (keypad on both entry and exit side)
DGLSWL	Left handed, single sided (keypad one side, handle other side)
DGLSWR	Right handed, single sided (keypad one side, handle other side)

Latchbolt: Adjustable, moves 22mm (7/8"). Auto-latching when gate closes.

Keep is included with lock.

Strike plate to be used for outward opening gates only. To install, slot it behind the keep and fix to the gate post as shown on page 2.



INSTALLATION

1. Position angle bracket on edge of the gate (can overhang edge of gate by up to 15mm (9/16") if required to accommodate a gap between the gate and gate post) and mark 3 holes for the outside keypad fixing screws and spindle. Remove angle bracket and drill 3 holes at minimum 9mm (3/8") diameter through the gate. Ensuring the holes are drilled straight is important to reduce the risk of the lock binding.
2. Cut the 2 x M5 screws and the spindle to length to suit the gate thickness. M5 screws should be cut to gate thickness less 16mm (5/8"). The spindle should be cut to gate thickness plus 68mm (2-5/8") for double sided and plus 82mm (3-1/4") for single sided.
3. Fit the outside keypad and angle bracket using M5 screws. (CAUTION: when fitting to wooden gates, ensure screws are not over-tightened as wood can expand causing fixing failure). Insert spindle, ensuring it has plenty of clearance inside the hole (hole can be enlarged if there is risk of binding).
4. Fix angle bracket securely using screws through the remaining 2 countersunk holes.
5. Position lock on to the spindle and fix to the angle bracket using 2 x M8 countersunk screws.
6. Test the lock to check it operates freely.
7. For all locks, fix the keep to the gate post by measuring the correct position and installing with the included screws. For outward opening gates, fix the strike plate to the gate post as shown on p. 2.
8. **ADJUSTMENT** To adjust latchbolt length insert 3mm (1/8") long arm hex key (supplied) into end of bolt and release locking screw. Rotate bolt as required and re-tighten locking screw. Lubricate with light oil periodically.

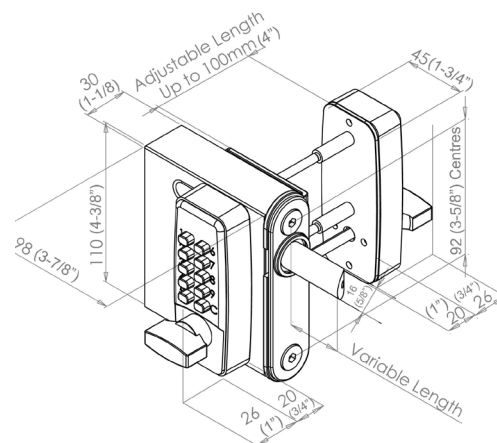

Installation video

G GATEMASTER

VISIT GATEMASTERLOCKS.COM FOR MORE INFORMATION

SURFACE FIXED DIGITAL GATE LOCK



INWARD OPENING GATES

For inward opening gates, you have to install the keep on the gate post as described on p. 1.

OUTWARD OPENING GATES

For outward opening gates, fix the included strike plate to the outside of the gate post. This is done by slotting it in behind the keep and fixing with the screws.



LOCK CODE:

C _ _ _

TO CHANGE THE CODE

1. Check the original code is working on both keypads
2. For standalone keypad: remove rear black plate from keypad using flat screwdriver or similar tool as seen below.
For DGLW double sided locks - to remove the keypad attached to the lock:
Left handed lock - Slide out the internal lock mechanism and the keypad can be removed by accessing the screws through the inside of the lockcase.
Right handed lock - Insert a flat screwdriver into the hole in the forend plate and lever out the keypad retaining plate (see image opposite). This will release the keypad.
3. Turn the keypad over and remove the 4 red screws
4. Lift off the covering panel. Be careful as there are 10 springs attached to this panel. Note that the red tumblers relate to the code shown above. Also note that the C tumbler is uncoloured and should not be removed.
5. To change the code hold the keypad with the code buttons down and depress and hold the C button (if this is not done you may damage some of the internal components). Reposition the tumblers to the new code (red tumblers are coded and blue tumblers are uncoded). Ensure that the square cut-out on each tumbler is facing the outside of the lock body, also ensure that the coloured mark is facing upwards as pictured below. If any one tumbler is upside down or the wrong way round the lock will not work and if forced will break the internal components. The code must always start with a 'C'.
6. Replace the covering panel and tighten the 4 red screws.

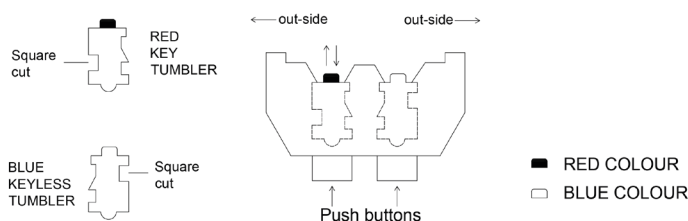
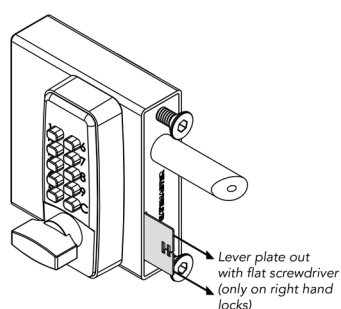

MAINTENANCE

Every 3 months:

1. Remove keypads from the lock
2. Spray the inside of the lock thoroughly with WD40 or equivalent, through the tumbler holes at the back of the lock
3. Spray all the fixing accessories and the latch with WD40 or equivalent.
4. Push each of the buttons and rotate the knob several times to make sure the lock is working smoothly



VISIT GATEMASTERLOCKS.COM FOR MORE INFORMATION

