

- I Ruota rivestita in materiale "Vulcolan" a 2 cuscinetti • gola V per **ANGULA**
- UK "Vulcolan" coated wheel 2 bearings • V groove
- D "Vulcolan" verkleidert. Rolle 2-Lager • V Nut
- F Roue revêtue "Vulcolan" 2 roulements • gorge V
- E Rueda recubierta "Vulcolan" 2 Cojinetes • guía V

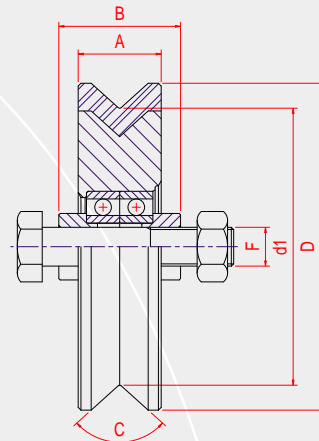

ARTICOLO-ARTICLE	D	F	C	A	B	d1	PORTATA CAPACITY			€
Riferimento-Reference	Ø	UNI	V	mm	mm	Ø		N°		X 1
1230 VN RN 12 30 V2	120	M14x70	96°	30	44	100	180	8	11,5	

- I Ruota rivestita in materiale "Vulcolan" a 2 cuscinetti • gola O per
- UK "Vulcolan" coated wheel 2 bearings • O groove
- D "Vulcolan" verkleidet. Rolle 2 Lager • O Nut
- F Roue revêtue "Vulcolan" 2 roulements • gorge O
- E Rueda recubierta "Vulcolan" 2 cojinetes • guía O

NEW OMEGA **NEW OMEGA 2**
FLOOR **HEAVY**

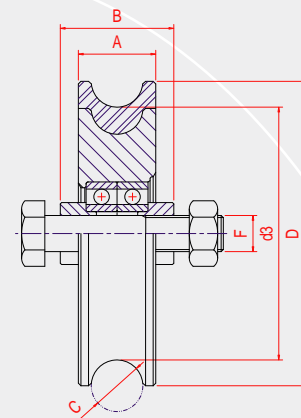
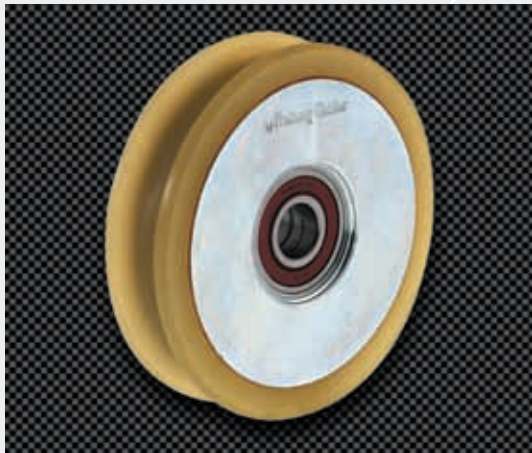

ARTICOLO-ARTICLE	D	F	C	A	B	d3	PORTATA CAPACITY			€
Riferimento-Reference	Ø	UNI	O	mm	Ø	mm	N°			X 1
1230 ON RN 12 30 O2	120	M14x70	21	30	44	100	210	8	11,5	

- I Ruota rivestita in materiale "Vulcolan" a 1 cuscinetto • gola V con supporto per
- UK "Vulcolan" coated wheel 1 bearing • V groove with support
- D "Vulcolan" verkleidert. Rolle 1-Lager • V Nut mit Stuetzplatten
- F Roue revêtue "Vulcolan" 1 roulement gorge • V avec support
- E Rueda con soporte recubierta "Vulcolan" 1 cojinete • guía V

ANGULA

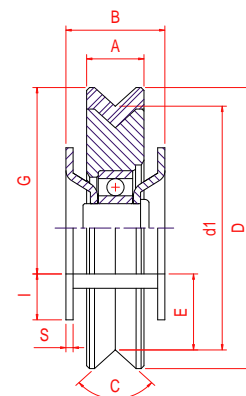
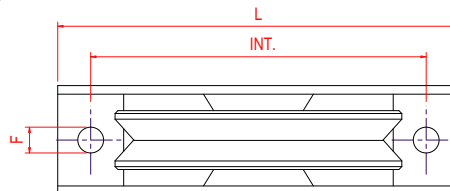
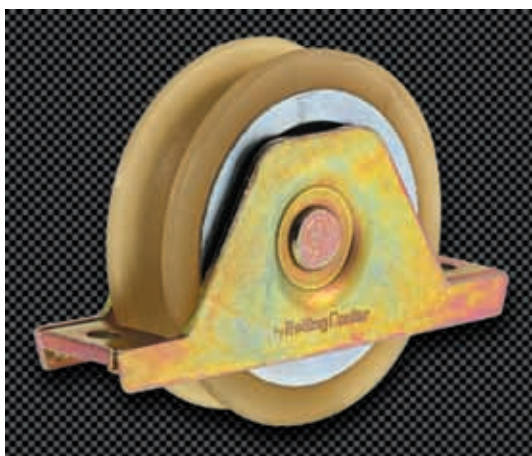

ARTICOLO-ARTICLE	D	A	B	C	G	I	E	S	d1	INTERASSE x F WHEELBASE x F	PORTATA CAPACITY			€
Riferimento-Reference	Ø	mm	V	mm	mm	mm	mm	mm	mm	mm	N°			X 1
920 PSVN RN 90 20 VS	90	20	32	96°	63	12	18,5	3	75	117 x Ø9	150	12	9	

- I Ruota rivestita in materiale "Vulcolan" a 1 cuscinetto • gola O con supporto per
- UK "Vulcolan" coated wheel 1 bearing • O groove with support
- D "Vulcolan" verkleidert. Rolle 1-Lager • O Nut mit Stuetzplatten
- F Roue revêtue "Vulcolan" 1 roulement • gorge O avec support
- E Rueda con soporte recubierta "Vulcolan" 1 cojinete • guía O

NEW OMEGA **NEW OMEGA 2**
FLOOR **HEAVY**

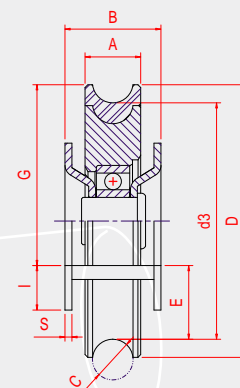
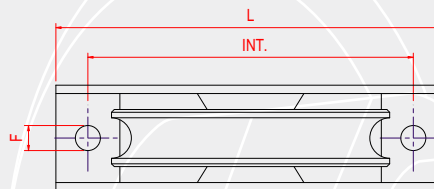
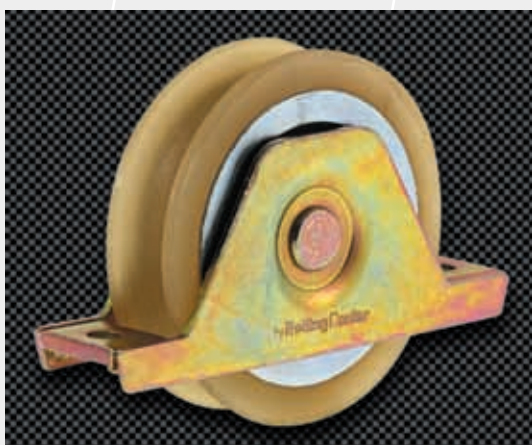

ARTICOLO-ARTICLE	D	A	B	C	G	I	E	S	d3	INTERASSE x F WHEELBASE x F	PORTATA CAPACITY			€
Riferimento-Reference	Ø	mm	O	mm	mm	mm	mm	mm	mm	mm	N°			X 1
926 PSON RN 90 26 OS	90	26	34	21	63	12	16	3	70	117 x Ø9	150	12	9,7	