

I Carrello "Magnum" per cancelli autoportanti con spazzolino

- UK Cantilever "Magnum" gate carriage with brusc - holder
- D Freitragendes "Magnum" Gatterwagen mit Bürstenhalter
- F Chariot "Magnum" pour portail autoportant avec porte - brosse
- E Carril "Magnum" par cancelas autoportantes con cepillo pequeño
- RUS Тележка «Магнум» для раздвижных ворот со щетками

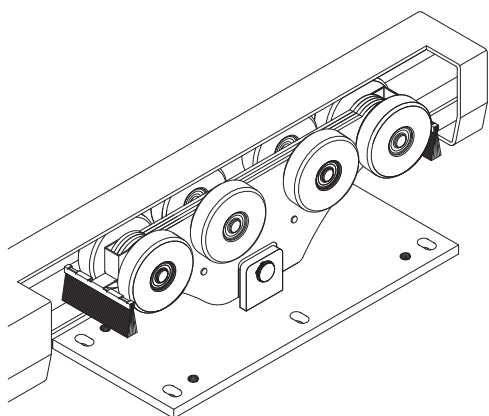
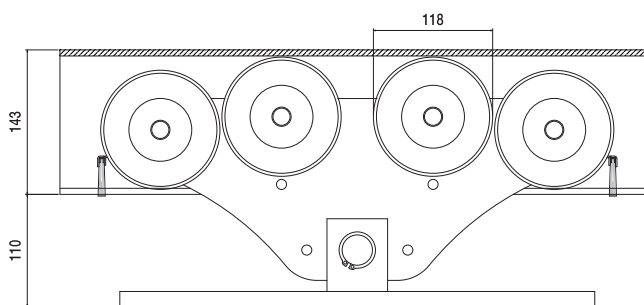
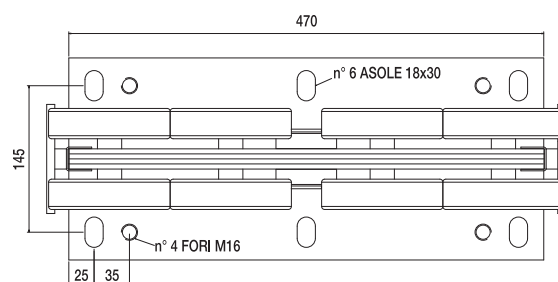
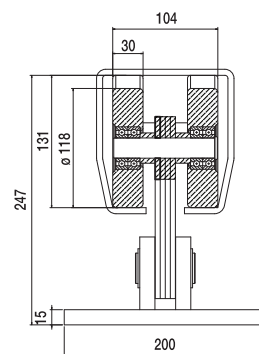

Articolo - Article		L1	Peso cancello Gate weight	Abbinabile Combining	
Riferimento - Reference		Max ML			N°
CA 4 RMS	LT 01 20 80	16	1200	GIPI 4 RM / MG	1 44,6

I Cannello industriale autoportante lunghezza mt. 15

- UK Industrial Cantilever gate L. 15m.
- D Industrie - Selbsttragend.Tor L. 15 M.
- F Portail industriel autoporté L. 15 mt.
- E Cancela industrial autoportante 15 metros de paso
- RUS Ворота промышленные сдвижные длина - 15 M.



I Guida per cancelli scorrevoli autoportanti

UK Guide for sliding cantilever gates

D Profilschiene für freitragende Schiebetore

F Rail pour portail suspendu

E Correderas autoportantes

RUS Балка несущая для сдвижных ворот

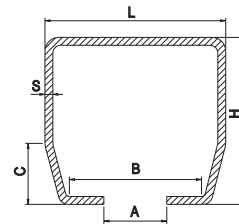

Typo Type	Articolo - Article		Abbinabile Combining	L	H	A	B	C	S	L1	Descrizione Description	Fasci Sheafs
	Riferimento - Reference			mm								ML
□	GIPI 4 RP 3	BG 70 60 03	CA 4 RPS	70	60	22	53	25	3,5	0/3 ML	Grezzo da ML 3	96 545
	GIPI 4 RP 6	BG 70 60 00		70	60	22	53	25	3,5		Grezzo da ML 6	192 1092
	GIPI 4 RPZ 3	BZ 70 60 03		70	60	22	53	25	3,5		Zincato da ML 3	96 545
	GIPI 4 RPZ 6	BZ 70 60 00		70	60	22	53	25	3,5		Zincato da ML 6	192 1092
□	GIPI 4 RG 3	BG 94 87 03	CA 4 RS	94	85	33	73	30	5	3/8 ML	Grezzo da ML 3	60 714
	GIPI 4 RG 6	BG 94 87 00		94	85	33	73	30	5		Grezzo da ML 6	120 1428
	GIPI 4 RGZ 3	BZ 94 87 03		94	85	33	73	30	5		Zincato da ML 3	60 714
	GIPI 4 RGZ 6	BZ 94 87 00		94	85	33	73	30	5		Zincato da ML 6	120 1428
□	GIPI 4 RM 3	BG 13 14 03	CA 4 RMS	136	143	38	104	55	6	10/16 ML	Grezzo da ML 3	45 1020
	GIPI 4 RM 6	BG 13 14 06		136	143	38	104	55	6		Grezzo da ML 6	90 2034
	GIPI 4 RMZ 3	BZ 13 14 03		136	143	38	104	55	6		Zincato da ML 3	45 1020
	GIPI 4 RMZ 6	BZ 13 14 06		136	143	38	104	55	6		Zincato da ML 6	90 2034

I Ruota di sostegno

UK Support wheel

D Stützrad

F Roue de support

E Rueda de soporte con placa para atornillar

RUS Ролик концевой

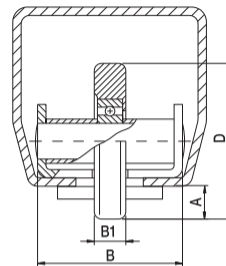
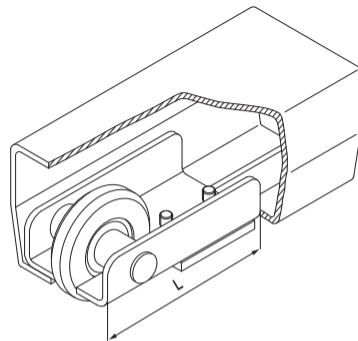



Articolo - Article		B	B1	L	A	D	Abbinabile Combining		
Riferimento - Reference		mm				∅		N°	
41 B	LT 00 50 10	50	15	125	13,5	68	GIPI 4RP/PZ	10	10,2
41 P	LT 00 74 10	68	15	125	15	74	GIPI 4RG/GZ	10	12
41 G	LT 00 98 10	105	30	16	14	98	GIPI 4RMMZ	2	6,5

I Incontro

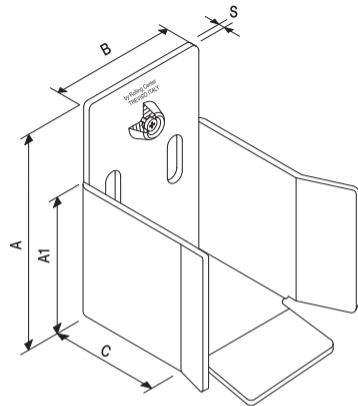
- UK Meeting point
- D Führungsendstück
- F Butée
- E Punto de recepción
- RUS Ловушка



Articolo - Article		A	A1	B	C	S	Abbinabile Combining		
Riferimento - Reference		mm						N°	
50 B	FT 15 80 00	130	76	87	82	4	GIPI 4RP/PZ	2	2,4
50 P	FT 16 10 00	161	96	112	82	4	GIPI 4RG/GZ/GA	5	8,4
50 G	FT 22 15 00	221	155	152	82	4	GIPI 4RM/MZ	2	5,6

Carrelli autoportanti

I Tabella di calcolo orientativo

- UK Indicative calculation table
- D Anzeigend. Kalkulation Tabelle
- F Tableau de calcul indicatif
- E Tabla indicativa del cálculo
- RUS Таблица расчета фундамента

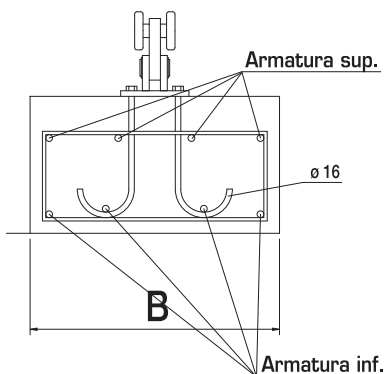

Abbinabile Combining	Cancello Gate							Portata Capacity	Peso Kg. x ML	Fondazione			
	L1	L2	L3 Max	L4	LT	H	E			A	B	C	Armatura
	ML	ML	ML	ML	ML	ML	MM			ML	ML	ML	n° mm Inf. n° mm Sup.
CA 4 RPS	3	1	1	1,8	4,8	1	190	450	95	1,8	0,6	0,5	4 Ø 12 4 Ø 12
	4	1,3	1	2,3	6,3	1	300	600	95	2,5	0,6	0,5	4 Ø 12 4 Ø 12
CA 4 RS	5	1,5	1,5	2,5	7,5	1	300	600	80	2,8	0,6	0,5	4 Ø 12 4 Ø 12
	6	1,8	1,5	2,8	8,8	1	300	600	70	3,2	0,6	0,5	4 Ø 12 4 Ø 12
CA 4 RMS	8	2,4	1,5	3,4	11,4	1	300	600	55	3,7	0,6	0,5	7 Ø 12 4 Ø 12
	10	3	2	4,4	14,4	1	470	1200	85	4,2	0,6	0,5	6 Ø 12 4 Ø 12
	12	4	2	5,4	17,4	1	470	1200	70	4,8	0,8	0,6	7 Ø 12 4 Ø 12
	14	4,2	2	5,6	19,6	1	470	1200	40	5,4	0,8	0,6	9 Ø 12 4 Ø 12
CA 4 RSN	16	4,8	2	6,2	22,2	1	470	1200	35	6	0,8	0,6	10 Ø 12 4 Ø 12
	3	1	1	1,8	4,8	1	300	350	80	1,8	0,6	0,5	4 Ø 12 4 Ø 12
CA 4 RSN	4	1,3	1	2,3	6,3	1	300	350	60	2,5	0,6	0,5	4 Ø 12 4 Ø 12
	5	1,5	1,5	2,5	7,5	1	300	350	50	2,8	0,6	0,5	4 Ø 12 4 Ø 12
	6	1,8	1,5	2,8	8,8	1	300	350	40	3,2	0,6	0,5	4 Ø 12 4 Ø 12

I Soluzioni orientative costruttive per cancelli autoportanti leggeri o pesanti

- UK Indicative construction solution for light and heavy cantilever gates
- D Anzeigende Bau-Loesungen fuer schwere und leichte selbsttragende Tore
- F Solution indicatives de construction pour portails autoportants légers et lourds
- E Soluciones indicativas de constucion para cancelas autoportantes livianas y pesadas
- RUS Примерные конструктивные решения для тяжелых или легких раздвижных ворот

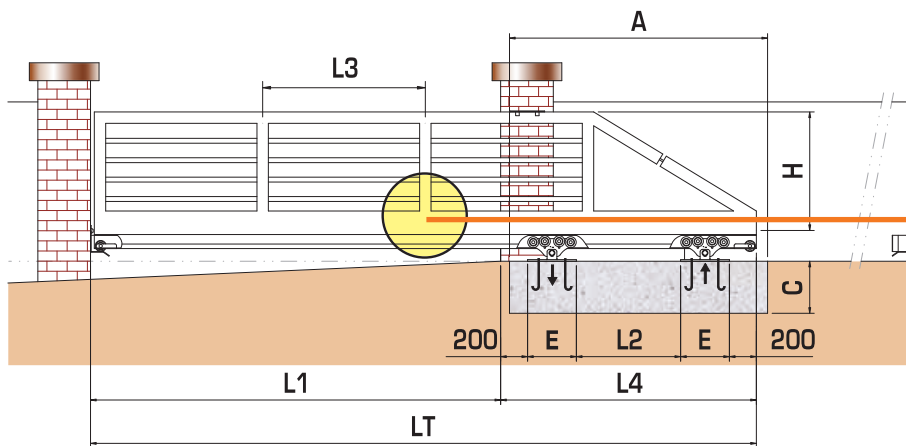

- I Leggero
- UK Light
- D Leicht
- F Léger
- E Liviano
- RUS Легкий

$$LT = L1 + L4 \quad L2 = 30\% \text{ di } L1 \quad L4 = L2 + (E + 200) \times 2$$

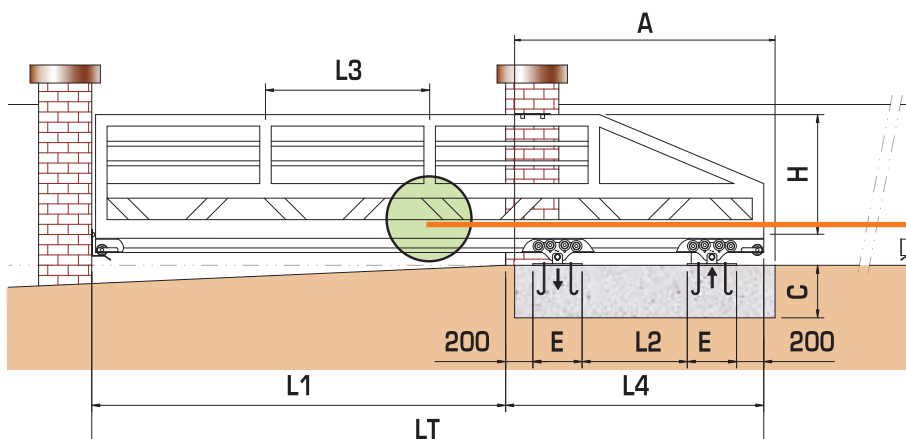

- I Pesante
- UK Heavy
- D Schwer
- F Lourd
- E Pesado
- RUS Тяжелый

I Esempio di cancello autoportante con accessori

- UK Example of cantilever gates with accessories
- D Beispiel von freitragende Schiebtore mit Zubehör
- F Exemple de porte autoportante et des accessoires
- E Ejemplo de cancela autoportante con accesorios
- RUS Образец автоматических раздвижных ворот с аксессуарами

