

CERNIERE
E CATENACCI

Hinges - Bolts
Scharniere - Riegel
Charnières - Verrous
Bisagras - Cerrojos
Шарниры и задвижки



CERNIERE E CATENACCI

I Cerniera in ferro a saldare a 2 ali chiuse con perno sfilabile grezza

- UK Black iron 2-closed wing hinge with removable pin to be welded
 D Schwarze Eisen Scharniere 2 geschlossen. Fluegel mit ausziehbar. Stifte zum schweissen
 F Charnière fer brut 2 volets fermés pivot dégonnable à souder
 E Bisagra hierro negro 2 alas cerradas con pernio extraíble para soldar
 RUS Петля черный металл с 2 закрытыми площадками под сварку разъемная

Articolo - Article		L	B	De	Di		
Riferimento - Reference		mm				N°	
133/60	EG 00 60 20	60	13	9,5	6	24	0,9
133/80	EG 00 80 20	80	16,5	12	8	24	1,8
133/100	EG 00 10 20	100	18	13,5	8,5	24	2,8
133/120	EG 00 12 20	120	19,5	15	10	24	4,3
133/140	EG 00 14 20	140	22	16,5	10,5	24	5,8
133/170	EG 00 17 20	170	23,5	17,5	12	12	4,2
133/200	EG 00 20 20	200	25	22	14	12	6,6

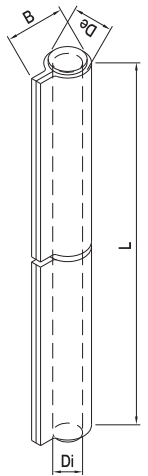

I Cerniera in ferro a saldare a 2 ali chiuse con perno fisso e con tappo grezza

- UK Black iron 2-closed wing plug hinge with fixed pin to be welded
 D Schwarze Eisen Scharniere 2 geschlossen. Fluegel mit fest. Stifte zum schweissen
 F Charnière fer brut 2 volets fermés avec bouchon pivot fixe à souder
 E Bisagra hierro negro 2 alas cerradas con pernio fijo para soldar
 RUS Петля черный металл с 2 закрытыми площадками под сварку неразъемная

Articolo - Article		L	B	De	Di		
Riferimento - Reference		mm				N°	
134/60	EG 00 60 21	60	17	12	8	24	1,2
134/80	EG 00 80 21	80	17	12	8	24	1,5
134/100	EG 00 10 21	100	19	13,5	9	24	2,3
134/120	EG 00 12 21	120	20	14,5	10	24	2,9
134/140	EG 00 14 21	140	21	16	11	24	4,1
134/170	EG 00 17 21	170	23,5	17	12	12	2,9
134/200	EG 00 20 21	200	26,5	20	14	12	4,6

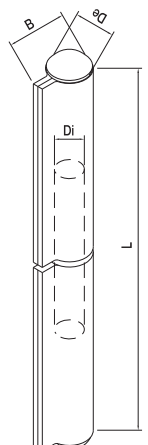

I Cerniera in ferro a saldare a 3 ali chiuse con perno sfilabile grezza

- UK Black iron 3-closed wing hinge with removable pin to be welded
 D Schwarze Eisen Scharniere 3 geschlossen. Fluegel mit ausziehbar. Stifte zum schweissen
 F Charnière fer brut 3 volets fermés pivot dégonnable à souder
 E Bisagra hierro negro 3 alas cerradas con pernio extraíble para soldar
 RUS Петля черный металл с 3 закрытыми площадками под сварку разъемная

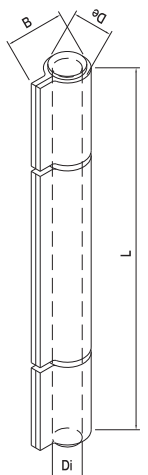

Articolo - Article		L	B	De	Di		
Riferimento - Reference		mm				N°	
135/80	EG 00 80 30	80	16,5	12	8	24	1,8
135/100	EG 00 10 30	100	18	13,5	8,5	24	2,7
135/120	EG 00 12 30	120	19,5	15	10	24	4,2
135/140	EG 00 14 30	140	22	16,5	10,5	24	5,7
135/170	EG 00 17 30	170	23,5	17,5	12	12	4,2
135/200	EG 00 20 30	200	27	20	14	12	6,6

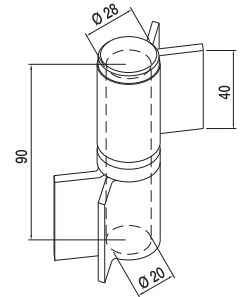

I Cerniera in ferro a saldare grezza a 2 ali aperte con perno sfilabile con rondella

- UK Black iron 2 open wing hinge with removable pin and ring to be welded
 D Schwarze Eisen Scharniere 2 offen. Fluegel mit ausziehbar. Stifte und Ring zum schweissen
 F Charnière fer brut 2 volets ouverts pivot dégonnable à souder
 E Bisagra hierro negro 2 alas abiertas con pernio extraible y anilla de seguridad para soldar
 RUS Петля черный металл с 2 открытыми площадками под сварку разъемная





Articolo - Article			
Riferimento - Reference		N°	
136	EG 00 90 20	8	4,2

I Cerniera in ferro a saldare grezza a 3 ali aperte con perno sfilabile con rondella grezza

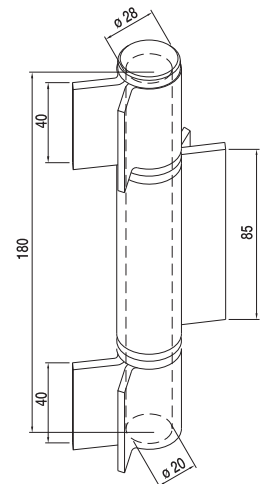
- UK Black iron 3 open wing hinge with removable pin and ring to be welded
 D Schwarze Eisen Scharniere 3 offen. Fluegel mit ausziehbar. Stifte und Ring zum schweissen
 F Charnière fer brut 3 volets ouverts pivot dégonnable à souder
 E Bisagra hierro negro 3 alas abiertas con pernio extraible y anilla para soldar
 RUS Петля черный металл с 3 открытыми площадками под сварку разъемная





Articolo - Article			
Riferimento - Reference		N°	
137	EG 00 18 30	4	4,2

I Cerniera in ferro a saldare grezza a 4 ali aperte con perno sfilabile con rondella grezza

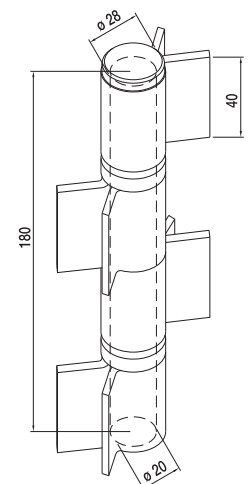
- UK Black iron 4 open wing hinge with removable pin and ring to be welded
 D Schwarze Eisen Scharniere 4 offen. Fluegel mit ausziehbar. Stifte und Ring zum schweissen
 F Charnière fer brut 4 volets ouverts pivot dégonnable à souder
 E Bisagra hierro negro 4 alas abiertas con pernio extraible y anilla para soldar
 RUS Петля черный металл с 4 открытыми площадками под сварку разъемная



Articolo - Article			
Riferimento - Reference		N°	
138	EG 00 18 40	4	4,2

CERNIERE E CATENACCI

I Cerniera in ferro per porte blindate a saldare grezza a 2 ali con perno regolabile grezzo

- UK 2 wing-raw iron hinge with to be welded for steel-clad door with adjustable pin
 D 2-Fluegelschwarz. Scharnier zum schweissen fuer Panzer-Tuer mit regelbar. Stifte
 F Charnière brut 2 ailes à souder avec axe réglable pour porte blindée
 E Bisagra hierro negro 2 alas+pernio regulable+cojinete para puerta blindada para soldar
 RUS Петля черный металл с 2 площадками под сварку, для тяжелых дверей регулируемая с подшипником

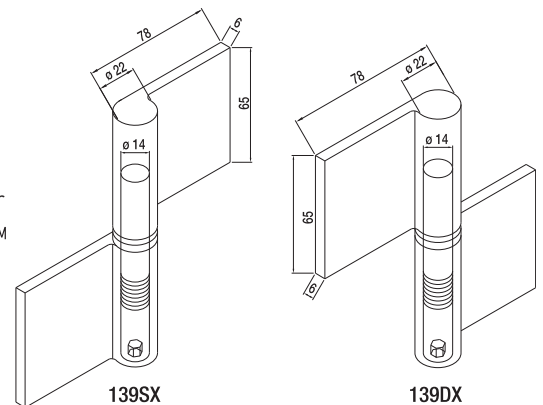

Articolo - Article		N°	
Riferimento - Reference		N°	kg
139DX	EG 00 78 OD	6	4,3
139SX	EG 00 78 OS	6	4,3

I Cerniera in ferro con ala lunga a saldare reversibile grezza con cuscinetto reggispinta

- UK Long wing reversible raw iron hinge with thrust bearing
 D Lang. -1-Fluegel schwarz. Umkehrbar. Scharnier mit Drucklager
 F Charnière réversible fer brut à une aile longue avec roulement de butée
 E Bisagra hierro negro con ala larga para soldar reversible rústica con rolinera detén empujon
 RUS Железный шарнир с длинным двусторонним крылом для сварки с упорным подшипником

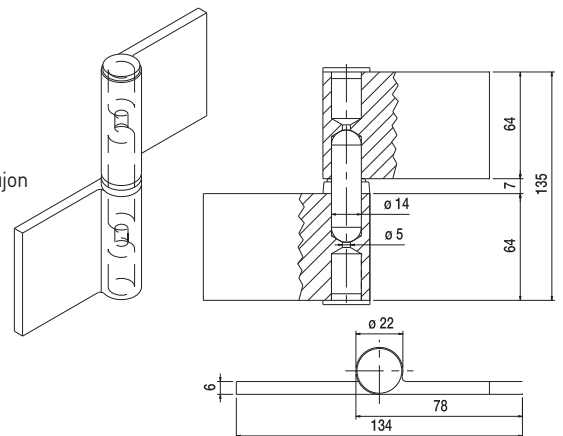

Articolo - Article		Mat. Perno	
Riferimento - Reference		Descrizione Description	N°
156/A	EG 78 64 00	Acciaio	20 13,8
156/O	EG 78 64 01	Ottone	20 13,8

I Cerniera in ferro con ala mozzata a saldare reversibile grezza con cuscinetto reggispinta

- UK Reversible shortened-wing raw iron hinge to be welded with thrust bearing
 D Gekuerzt-Fluegel schwarz. Umkehrbar. Scharnier zum schweissen mit Drucklager
 F Charnière réversible fer brut, aile raccourcie à souder avec roulement de butée
 E Bisagra hierro negro con ala recortada para soldar reversible rústica con rolinera detén empujon
 RUS Железный шарнир с укороченным двусторонним крылом для сварки с упорным подшипником

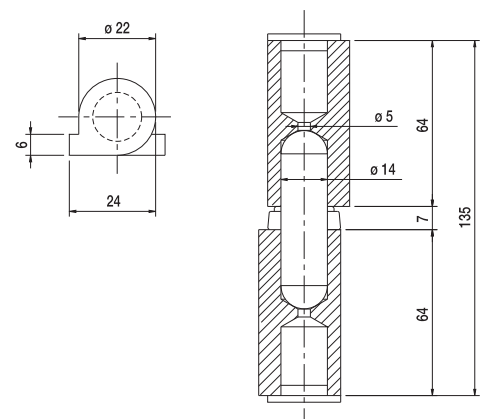

Articolo - Article		Mat. Perno	
Riferimento - Reference		Descrizione Description	N°
159/A	EG M0 22 64	Acciaio	12 5,3
159/O	EG M1 22 64	Ottone	12 5,3

I Cerniera a goccia ø 22x25 con cuscinetto reggispinta

- UK Drop shaped hinge ø 22x25 with thrust bearing
D Tropfen-Scharnier ø 22x25 mit Drucklager
F Charnière forme goutte ø 22x25 avec roulement de butée
E Bisagra en gota ø 22x25 con rolinera detén empujon (freno)
RUS Каплеобразный шарнир ø 22x25 с упорным подшипником

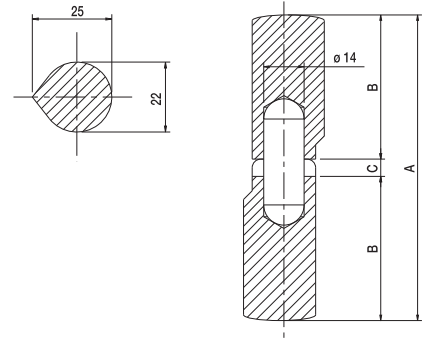

Articolo - Article		A	B	C	Mat. Perno		
Riferimento - Reference		mm			Descrizione Description	N°	kg
157/64	EG G0 22 64	135	64	7	Acciaio	12	4,9
157/75	EG G0 22 75	157	75	7	Acciaio	12	5,6
157/100	EG G0 22 10	207	100	7	Acciaio	12	7,5
158/64	EG G1 22 64	135	64	7	Ottone	12	5
158/75	EG G1 22 75	157	75	7	Ottone	12	5,7
158/100	EG G1 22 10	207	100	7	Ottone	12	7,6

STILO

I La cerniera STILO è l'accessorio ideale per la realizzazione di cancelli ad ante pesanti, di porte di grandi dimensioni, di porte blindate, grazie alle sue tre ali robuste in acciaio saldabili ed alla sua alta resistenza; in sintesi:

- presenza di un ingrassatore per periodici interventi di manutenzione
- garanzia di antiscasso ed antisfilamento, costituita dalla sigillatura all'estremità dl perno (trafilato con ø 20 mm) al momento dell'assemblaggio in produzione
- presenza di due grani di bloccaggio per l'allineamento delle due ali esterne con quella centrale
- garanzia di sopportare carichi sostenuti fino a 400 Kg con antiusura assicurata nel tempo

UK The STILO hinge is the ideal accessory for heavy wings gates, large doors and armoured doors, thanks to its strong weldable steel wings and its high resistance. Advantages at a glance:

- equipped with a lubricator for periodic maintenance
- burglary resistant security guaranty, thanks to the sealing at the end of the pin (ø 20 mm drawing), during assembling.
- availability of 2 stop beads for the alignment of the two external wings with the central one.
- guaranteed wear-proof bearing up to 400kg loads.

D Mit seinen 3 starken schweißbaren Stahlflügeln ist das STILO Anschweißband der perfekte Zubehör für Tore und Türen mit schweren Flügeln und für große und verstärkte Türen. Vorteile:

- fettpresse Versorgung für eine regelmäßige Instandhaltung.
- garantiert unzerbrechlich und aushängesicher: Sicherung am Ende des Gewindes ø 20 mm Stift, eingearbeitet während der Herstellung;
- 2 sperrbare Federn zum Einstellen der 2 Außenflügel mit dem Mittelflügel;
- tragkraft bis 400 kg - Verschleißwiderstand über Jahre.

F Grâce aux côtés robustes et soudables en acier et à sa grande résistance, la charnière STILO est l'accessoire idéal pour réaliser des grilles à portes lourdes, de grandes dimensions et blindées. Elle offre les avantages suivantes:

- interventions périodiques de manutention de la part d'un graisseur
- assurance pour prévenir le défonçage constitué par un scellage à l'extrémité du pivot (tréfilé ø 20mm) posé au moment de l'assemblage en production
- système de blocage pour alignement de deux côtés latérales avec le central
- assurance de durée dans le temps et de résistance jusqu'à 400kg

E La cremallera STILO es el accesorio ideal para la realización de cancelas de hoja pesada, de puertas de grandes dimensiones y de puertas blindadas, gracias a sus tres robustas alas de acero soldable y a su alta resistencia. En síntesis:

- presencia de un lubricador para periódicos intervalos de manutención
- sistema antirrobo y antiapertura, constituido por el sellado en la extremidad del pernio (trafilado con 20 mm)
- presencia de dos tornillos de bloqueo para el alineamiento de las dos alas exteriores con la central
- garantía de soportar cargas sostenidas hasta 400 kg con antidesgaste asegurada en el tiempo

RUS Петля STILO - идеальный аксессуар для установки ворот с тяжелыми створками, больших и бронированных дверей, благодаря их крепким свариваемым стальным створкам и их высокому сопротивлению:

- маслораспылитель для периодического технического обслуживания
- защита от взлома и гарантия безопасности с помощью герметизации на конце штифта ø20 мм во время монтажа
- возможность использования 2 тормозных валиков для выравнивания 2 внешних створок с центральной
- гарантируемая способность выдержать нагрузку до 400 кг

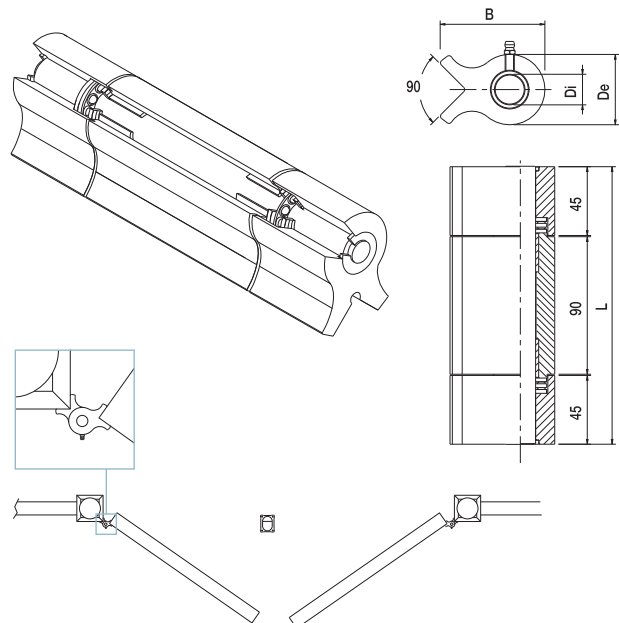

Articolo - Article L		B	De Di		
Riferimento - Reference		mm		N°	kg
139P	ET 46 18 30	182	68,5 46 20	4	12

CERNIERE E CATENACCI

I Catenaccio ad avvitare asta tonda pesante con portalucchetto

- UK Barrel bolt for padlock heavy duty to be screwed
- D Riegel zum einschrauben fuer Vorhaengeschooss
- F Verrou rond à visser avec porte cadenas modèle lourd
- E Cerrojo a atornillar con barra redonda pesada para candado
- RUS Задвижка круглая под винт и навесной замок усиленная

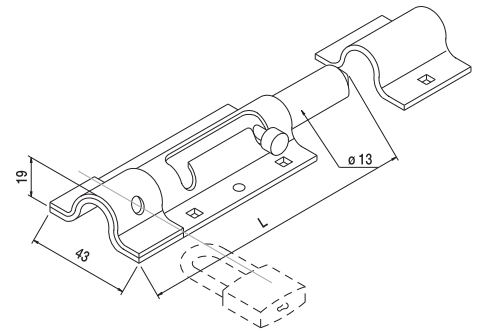

Articolo - Article		L	📦	
Riferimento - Reference		mm	N°	kg
110/150	AT 43 15 13	150	10	3,2
110/200	AT 43 20 13	200	10	4,1
110/250	AT 43 25 13	250	10	5,1

I Catenaccio ad avvitare asta tonda leggero con portalucchetto

- UK Barrel bolt for padlock light duty to be screwed
- D Riegel zum schrauben fuer Vorhaengeschooss
- F Verrou rond à visser avec porte cadenas modèle léger
- E Cerrojo a atornillar con barra redonda pesada para candado
- RUS Задвижка круглая под винт и навесной замок усиленная

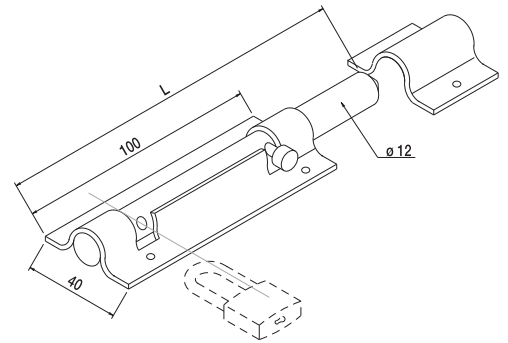
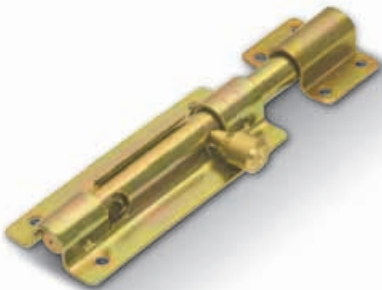

Articolo - Article		L	📦	
Riferimento - Reference		mm	N°	kg
111/150	AT 40 15 12	150	10	2,2
111/200	AT 40 20 12	200	10	2,7

I Catenaccio a saldare asta tonda

- UK Barrel bolt with staple on request to be welded
- D Riegel zum schweissen mit Endschuh auf Anfrage
- F Verrou rond à souder avec gache sur demande
- E Cerrojo a soldar con barra pesada
- RUS Задвижка круглая под сварку с пазом

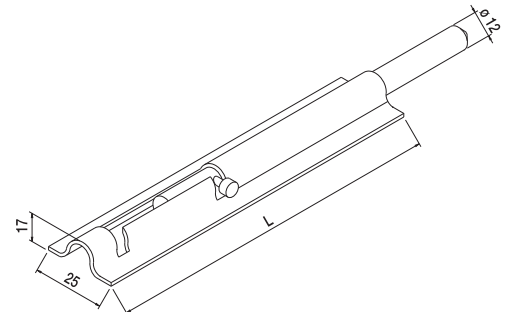

Articolo - Article		L	📦	
Riferimento - Reference		mm	N°	kg
112/150	AT 25 15 13	150	10	4,6
112/200	AT 25 20 13	200	10	5,6
112/250	AT 25 25 13	250	10	5,9
112/300	AT 25 30 13	300	10	7,1
112/400	AT 25 40 13	400	10	7,6
112/500	AT 25 50 13	500	10	8,8

**I Catenaccio a traverso ad avvitare rinforzato
compreso di incontro**

- UK Reinforced crossed bolt with staple to be screwed
- D Verstärkert kreuz. Riegel zum einschrauben mit Endschuh
- F Verrou renforcé à visser avec gache horizontal
- E Cerrojo horizontal reforzado con gancho a atornillar
- RUS Задвижка плоская с ответной частью под винт усиленная

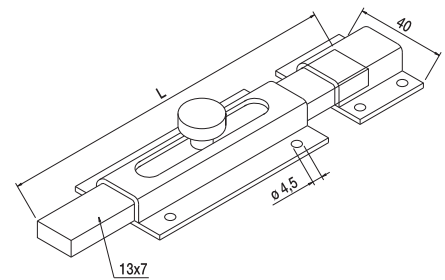
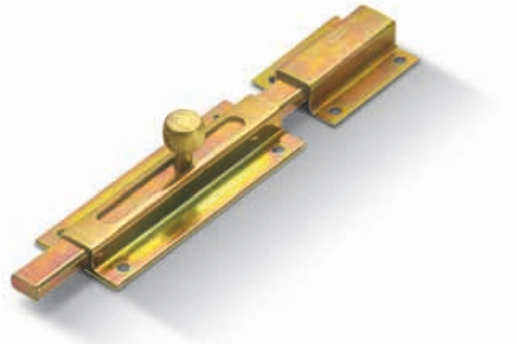

Articolo - Article		L		
Riferimento - Reference		mm	N°	kg
114/80	AT 40 80 13	80	10	1,2
114/120	AT 40 12 13	120	10	1,8
114/160	AT 40 16 13	160	10	2,2
114/200	AT 40 20 13	200	10	2,7

**I Catenaccio di traverso ad avvitare leggero
compreso di incontro e portalucchetto**

- UK Light crossed bolt with staple for padlock to be screwed
- D Leicht kreuz. Riegel zum einschrauben mit Endschuh fuer Vorhaengeschooss
- F Verrou transversal léger à visser avec gache et porte cadenas
- E Cerrojo horizontal liviano con gancho para candado a atornillar
- RUS Задвижка плоская с ответной частью под винт и навесной замок легкая

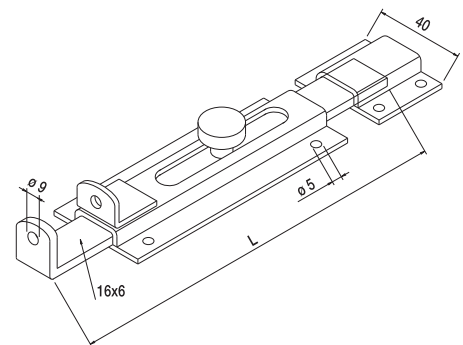
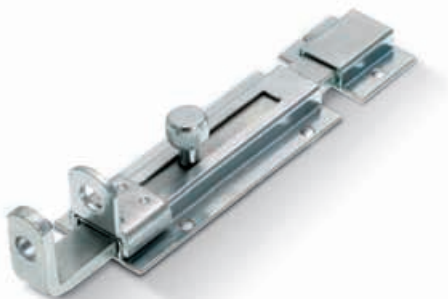

Articolo - Article		L		
Riferimento - Reference		mm	N°	kg
115/100	AZ 40 10 16	100	10	2
115/150	AZ 40 15 16	150	10	2,7
115/180	AZ 40 18 16	180	10	3
115/230	AZ 40 23 16	230	10	3,6

**I Catenaccio di traverso ad avvitare pesante
compreso di incontro e portalucchetto**

- UK Heavy crossed bolt with staple for padlock to be screwed
- D Schwer kreuz. Riegel zum einschrauben mit Endschuh fuer Vorhaengeschooss
- F Verrou transversal lourd à visser avec gache et porte cadenas
- E Cerrojo horizontal a atornillar pesado con gancho para candado
- RUS Задвижка плоская с ответной частью под винт и навесной замок усиленная

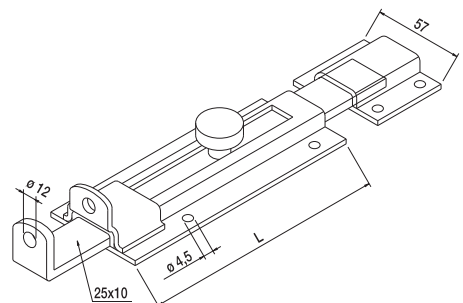
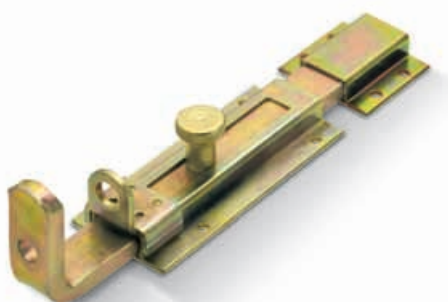

Articolo - Article		L		
Riferimento - Reference		mm	N°	kg
116/200	AT 57 20 25	200	5	4,2
116/300	AT 57 30 25	300	5	6,3
116/400	AT 57 40 25	400	5	8,4

CERNIERE E CATENACCI

I Catenaccio verticale ad avvitare leggero con incontro a richiesta

- UK Light vertical bolt to be screwed with staple on request
 D Leicht vertikal Riegel zum einschrauben mit Endschuh auf Anfrage
 F Verrou vertical léger à visser avec gache sur demande
 E Cerrojo vertical a atornillar liviano con gancho sobre pedido
 RUS Задвижка плоская вертикальная под винт с пазом легкая

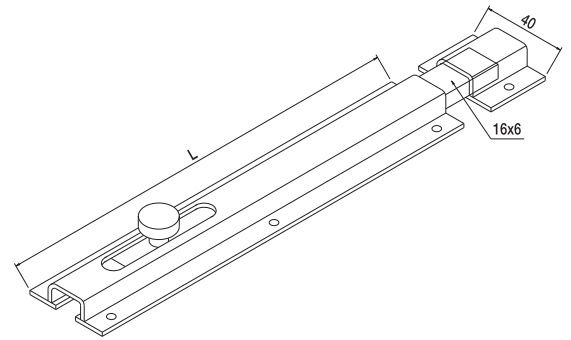
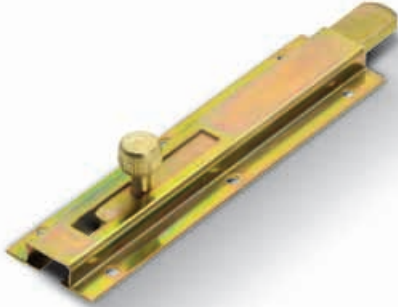

Articolo - Article		L	📦	
Riferimento - Reference		mm	N°	kg
117/150	AT 40 15 16	150	10	2,3
117/200	AT 40 20 16	200	10	3
117/250	AT 40 25 16	250	10	3,7
117/300	AT 40 30 16	300	10	4,3
117/400	AT 40 40 16	400	10	5,8
117/500	AT 40 50 16	500	10	7,1

I Catenaccio verticale ad avvitare pesante con incontro a richiesta

- UK Heavy vertical bolt to be screwed with staple on request
 D Schwer vertikal Riegel zum einschrauben mit Endschuh auf Anfrage
 F Verrou vertical lourd à visser avec gache sur demande
 E Cerrojo vertical pesado a atornillar con gancho sobre pedido
 RUS Задвижка плоская вертикальная под винт с пазом легкая

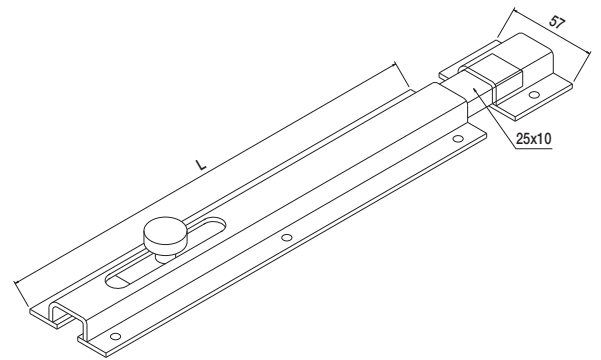
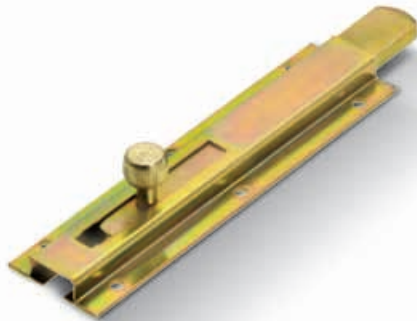

Articolo - Article		L	📦	
Riferimento - Reference		mm	N°	kg
118/200	AT 20 57 25	200	5	3,5
118/250	AT 25 57 25	250	5	4,3
118/300	AT 30 57 25	300	5	5,2
118/400	AT 40 57 25	400	5	6,9
118/500	AT 50 57 25	500	5	8,6

I Catenaccio ad avvitare leggero con incontro a richiesta

- UK Light bolt to be screwed with staple on request
 D Leicht Riegel zum einschrauben mit Endschuh auf Anfrage
 F Verrou léger à visser avec gache sur demande
 E Cerrojo liviano a atornillar con gancho sobre pedido
 RUS Задвижка под винт с пазом легкая

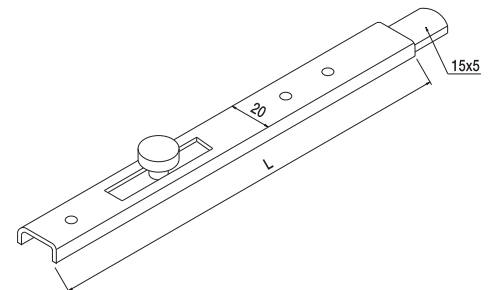
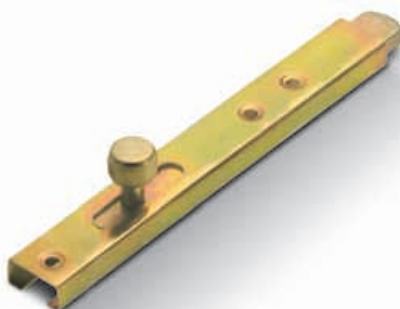

Articolo - Article		L	📦	
Riferimento - Reference		mm	N°	kg
119/150	AT 20 15 15	150	15	3,2
119/200	AT 20 20 16	200	15	2,9
119/250	AT 20 25 15	250	15	3,4
119/300	AT 20 30 15	300	15	4,5
119/400	AT 20 40 15	400	15	5,3
119/500	AT 20 50 15	500	15	7,5
119/600	AT 20 60 15	600	15	9,2
119/800	AT 20 80 15	800	15	12,6

I Catenaccio a saldare leggero con incontro a richiesta

- UK Light bolt to be welded with staple on request
D Leicht Riegel zum schweissen mit Endschuh auf Anfrage
F Verrou léger à souder avec gache sur demande
E Cerrojo liviano a soldar con gancho sobre pedido
RUS Задвижка под сварку легкая

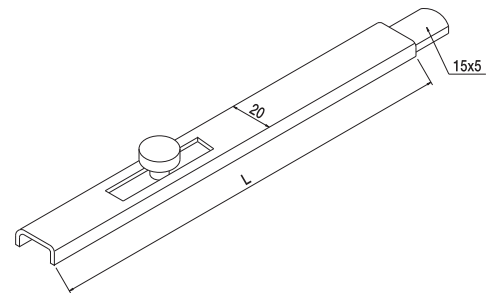

Articolo - Article		L	📦	
Riferimento - Reference		mm	N°	kg
120/150	AT 20 15 OS	150	15	2,6
120/200	AT 20 20 OS	200	15	3,5
120/250	AT 20 25 OS	250	15	4,3
120/300	AT 20 30 OS	300	15	5,1
120/400	AT 20 40 OS	400	15	6,8
120/500	AT 20 50 OS	500	15	8,4
120/600	AT 20 60 OS	600	15	9,6
120/800	AT 20 80 OS	800	15	12,7

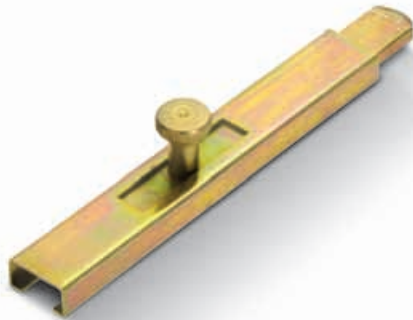

I Catenaccio a saldare pesante con incontro a richiesta

- UK Heavy bolt to be welded with staple on request
D Schwer Riegel zum schweissen mit Endschuh auf Anfrage
F Verrou lourd à souder avec gache sur demande
E Cerrojo pesado a soldar con gancho sobre pedido
RUS Задвижка под сварку усиленная

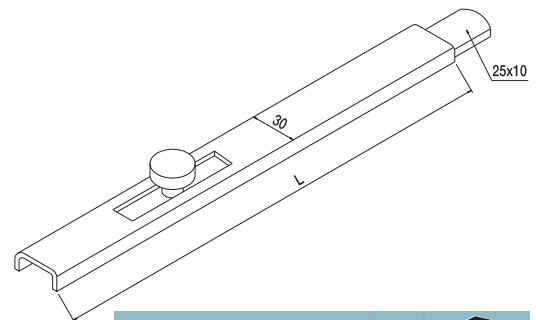

Articolo - Article		L	📦	
Riferimento - Reference		mm	N°	kg
121/150	AT 30 15 OS	150	5	1,5
121/200	AT 30 20 OS	200	5	2,8
121/250	AT 30 25 OS	250	5	3,4
121/300	AT 30 30 OS	300	5	4,1
121/400	AT 30 40 OS	400	5	5,3
121/500	AT 30 50 OS	500	5	6,7
121/600	AT 30 60 OS	600	5	8,0
121/800	AT 30 80 OS	800	5	10,7

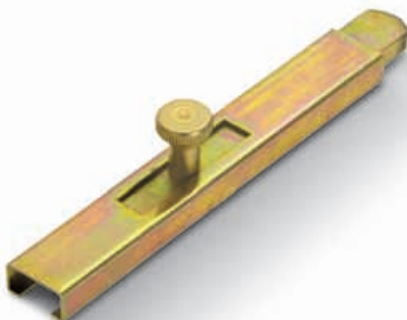

I Catenaccio a leva per serramenti in metallo ad azione singola

- UK Single action flush bolt for metal doors
D Hebel Riegel fuer Metall-Tuer einz. Bewegung
F Verrou à levier pour portes métal un mouvement
E Cerrojo a palanca para puertas metálicas (maniobra simple)
RUS Зашелка с ручкой для металлических створок 1-сторонняя

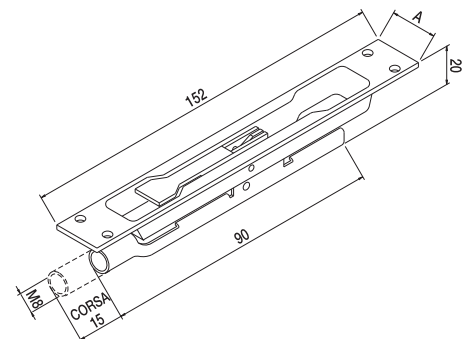

Articolo - Article		A	📦	
Riferimento - Reference		mm	N°	kg
122/16	AZ 16 15 1A	16	10	1,1
122/20	AZ 20 15 1A	20	10	1,1
122/24	AZ 24 15 1A	24	10	1,2

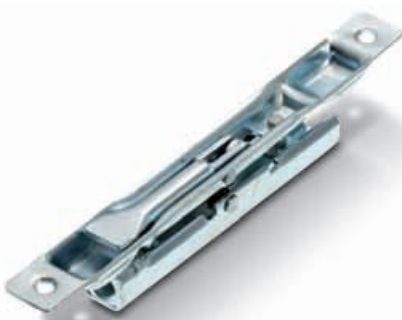

CERNIERE E CATENACCI

I Catenaccio a leva per serramenti in metallo a doppia azione

- UK Double action flush bolt for metal doors
- D Zwei-Bewegung. Hebel Riegel fuer Metall-Tuer
- F Verrou à levier pour portes métal double mouvement
- E Cerrojo a palanca para puertas metálicas (maniobra doble)
- RUS Защелка с ручкой для металлических створок 2-сторонняя

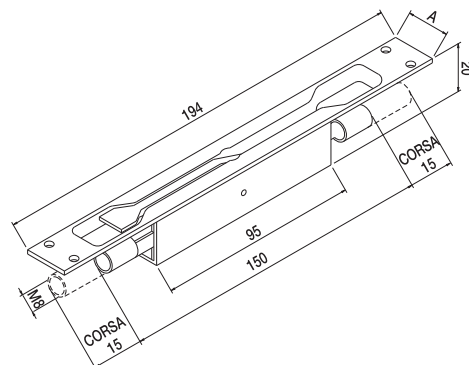

Articolo - Article		A		
Riferimento - Reference		mm	N°	
123/24	AZ 24 19 2A	24	10	3

I Catenaccio a leva in ottone per serramenti in metallo ad azione singola

- UK Single action brass flush bolt for metal doors
- D Messing Hebel Riegel fuer Metall-Tuer einz. Bewegung
- F Verrou à levier laiton pour portes métal un mouvement
- E Cerrojo a palanca en bronce para puertas metálicas (maniobra simple)
- RUS Защелка с бронзовой ручкой для металлических створок 1-сторонняя

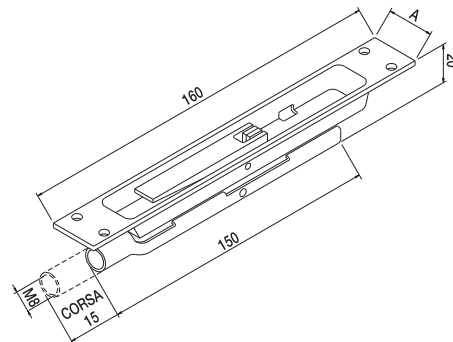

Articolo - Article		A		
Riferimento - Reference		mm	N°	
124/20	AZ 20 16 00	20	10	1,6
124/24	AZ 24 16 00	24	10	1,6

I Cricchetto con piastrina

- UK Plate for catch
- D Platte fuer Sperrklinke
- F Plaque pour loqueteau
- E Plaqueta con gancho
- RUS Защелка оконной фрамуги

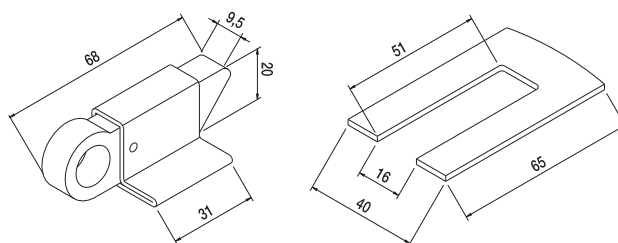
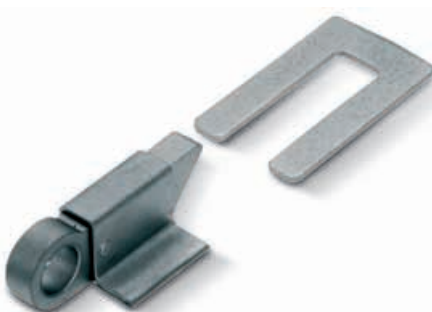

Articolo - Article			
Riferimento - Reference		N°	
125	AG 68 20 00	25	2,5

I Cremonese a leva a doppia azione per serramento in acciaio zincato

- UK Double action flush bolt for galvanized steel doors
D Hebel Riegel fuer verzinkte Stahl Tuere zwei Bewegungen
F Verrou à levier double mouvement pour acier galvanisé
E Cerrojo a palanca para puertas metálicas (maniobra doble) en acero galvanizado
RUS Задвижка с ручкой 2-сторонняя для стальных створок оцинкованная

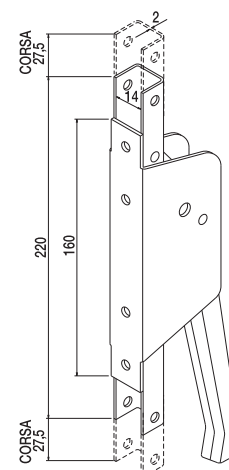

Articolo - Article		N°	
Riferimento - Reference			kg
127	AZ 20 16 14	5	4,0

I Scatola copriserratura a gancio zincata

- UK Galvanized lock cover box with hook
D Verzinkt. Schlosdeckelschachtel mit Haken
F Boite couvercle serrure galvanisée avec crochet
E Caja cubrecerradura con gancho galvanizado
RUS Корпус замка 129 оцинкованный

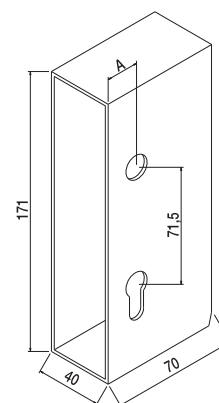

Articolo - Article		Per tubolare	A	N°	
Riferimento - Reference		mm	mm		kg
128/10	AZ 40 10 00	50	10	6	3,5
128/20	AZ 40 20 00	40	20	6	3,5

I Serratura a gancio zincata

- UK Galvanized for hook lock
D Verzinkt fuer Haken-Schloss
F Serrure à crochet galvanisée
E Cerradura con gancho galvanizado
RUS Замок для сдвижных ворот оцинкованный

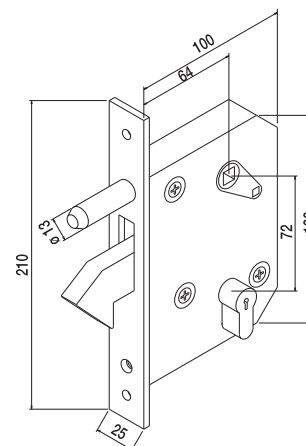

Articolo - Article		N°	
Riferimento - Reference			kg
129	AZ 25 21 00	1	1,3

CERNIERE E CATENACCI

I Maniglia per serratura porte metalliche

- UK Handle for lock for metal doors
 D Griffe fuer Schluessel fuer Metall-Tuer
 F Poignée pour serrure portes métalliques
 E Manilla para la cerradura para las puertas del metal
 RUS Ручка для замка металлической двери

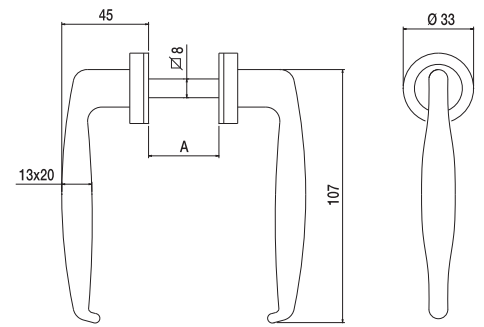

Articolo - Article		A		
Riferimento - Reference		mm	N°	kg
160	MN 10 45 Q0	25±38	15	2,5

I Paletto quadro leggero a saldare tropicalizzato

- UK Yellow galvanized light square stake to be welded
 D Gelbverzinkt leicht quadrat. Anschlag zum schweissen
 F Verrou carré léger à souder bichromaté
 E Cerrojo cuadrado liviano a soldar tropicalizado
 RUS Задвижка квадратная под сварку гальванизированная легкая

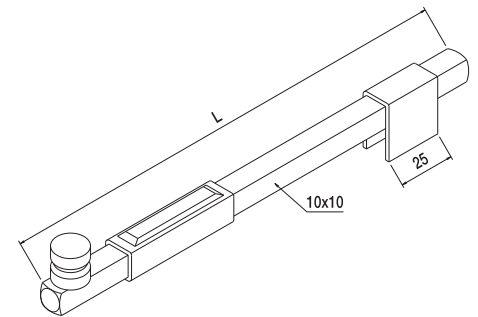

Articolo - Article		L		
Riferimento - Reference		mm	N°	kg
140/130	AT 13 10 00	130	15	2,4
140/300	AT 30 10 00	300	15	4
140/500	AT 50 10 00	500	15	7,5

I Paletto quadro leggero a saldare a punta rotonda tropicalizzato

- UK Yellow galvanized light square stake with rounded top to be welded
 D Abgerundet gelbverzinkt leicht quadrat. Anschlag zum schweissen
 F Verrou léger carré pointe arrondie à souder bichromaté
 E Cerrojo cuadrado liviano a soldar con punta redonda tropicalizado
 RUS Задвижка квадратная под сварку гальванизированная тяжелая

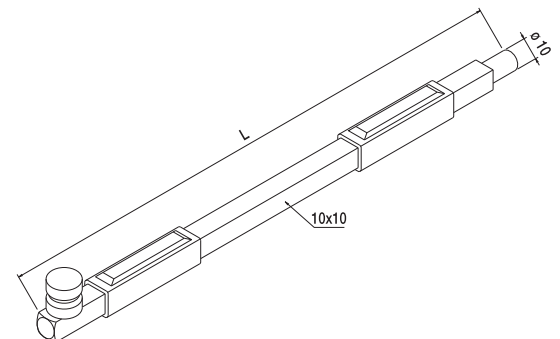

Articolo - Article		L		
Riferimento - Reference		mm	N°	kg
141/130	AT 13 10 10	130	15	2,4
141/300	AT 30 10 10	300	15	4
141/500	AT 50 10 10	500	15	7,5

I Paletto quadro pesante a saldare tropicalizzato

- UK Yellow galvanized heavy square stake to be welded
- D Gelbverzinkt schwer quadrat. Anschlag zum schweissen
- F Verrou carré lourd à souder bichromaté
- E Cerrojo cuadrado pesado a soldar tropicalizado
- RUS Задвижка квадратная с круглым окончанием под сварку гальванизированная легкая

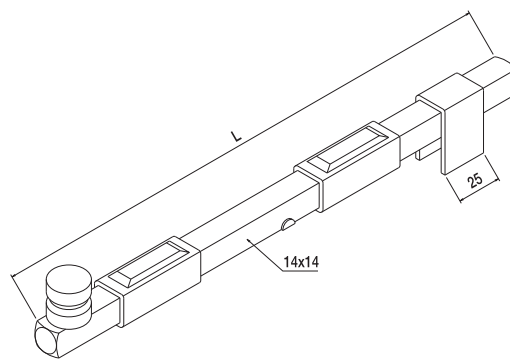
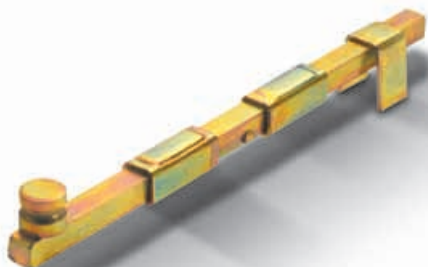

Articolo - Article		L	📦	
Riferimento - Reference		mm	N°	kg
142/330	AT 33 14 00	330	10	11,5
142/600	AT 60 14 00	600	10	12,0

I Paletto quadro pesante a saldare a punta rotonda tropicalizzato

- UK Yellow galvanized heavy square stake with rounded top to be welded
- D Abgerundet gelbverzinkt schwer quadrat. Anschlag zum schweissen
- F Verrou lourd carré pointe arrondie à souder bichromaté
- E Cerrojo cuadrado pesado a soldar con punta redonda tropicalizado
- RUS Задвижка квадратная с круглым окончанием под сварку гальванизированная тяжелая

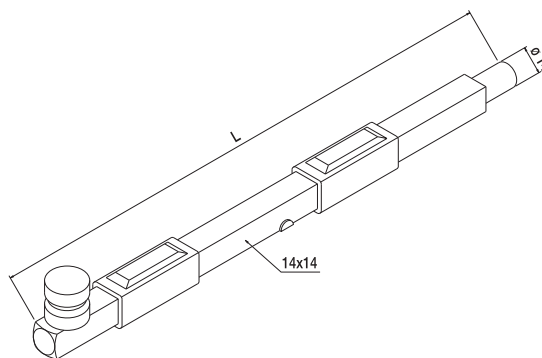
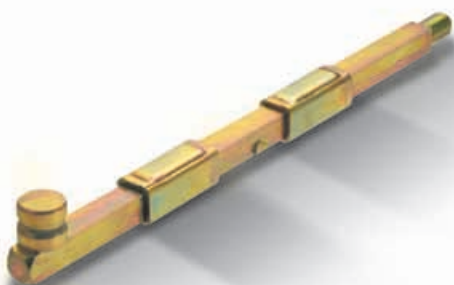

Articolo - Article		L	📦	
Riferimento - Reference		mm	N°	kg
143/330	AT 33 14 14	330	10	7,2
143/600	AT 60 14 14	600	10	12,0

I Paletto di bloccaggio tropicalizzato per cancelli ad ante motorizzati

- UK Blocking stake for automated gates
- D Torendanschlag mit Federauffangung
- F Verrou autobloquant pour portail à battants motorisés
- E Cerrojo autoblocante para cancelas motorizadas 2 hojas
- RUS Задвижка с самоблокирующаяся для распашных ворот с автоматикой

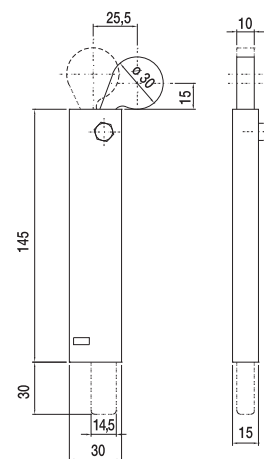

Articolo - Article		📦	
Riferimento - Reference		N°	kg
56	FT 30 15 00	20	9,5