

## For private, public and industrial car parks.

Electromechanical barrier gate operator with encoder.

### Powerful and quick:

electromechanical 24 Vdc gear motor, 300 W power and up to 250 Nm torque. It opens up completely (90°) in just 3 seconds (Signo4), 6 seconds (Signo6). Models with a 230 Vac or 110 Vac power supply.

### Even more sophisticated and well-developed new control unit

The same for all models, it automatically recognises and memorises the Signo model on which it is installed thereby eliminating the first installation procedure. Signals that the power supply is correct when started and that the control unit is functioning correctly.

Automatic diagnosis of faults when operating: this new function, which takes place during the normal operation of the automation, makes an automatic diagnosis of the faults detected by the control unit and signals the various types through a combination of flashes.

**Intelligent:** the manoeuvre will invert automatically if the bar comes into contact with an obstacle.

The control unit automatically corrects any eventual lack of balance linked to variations in the climate or poor installation.

**Safe:** the innovative control unit utilises a revolutionary management system of the force, speed, acceleration and deceleration that can be **programmed at 6 levels**, at the beginning and at the end of the manoeuvre.

Programming is intuitive and completely automatic with the Nice Encoder technology: Simply push a button and Signo will comprehend the limit switch limits.

**Large openings:** a master/slave selection automatically synchronises two barriers set opposite one another.

This means that entrances up to 8 and 12 m can be automate.

**Convenient:** separate compartments for electronics and mechanics provide the user with easy access without damages to internal parts.

### Exclusive functions:

- the barrier will close immediately after the vehicle has passed through
- it has two types of traffic-light type signals
- there is an automatic safety test at the beginning of each manoeuvre
- constant resistance STOP input for connecting the latest generation of sensitive edges
- there is a manoeuvre counter and it is possible to programme the maintenance alarm threshold

### Intensive use

The new 24 Vdc gear motor Signo can be used intensively for long periods of time. This characteristic makes it ideal for automating private, public or industrial car-parks which are subjected to the frequent passage of vehicles during the day.



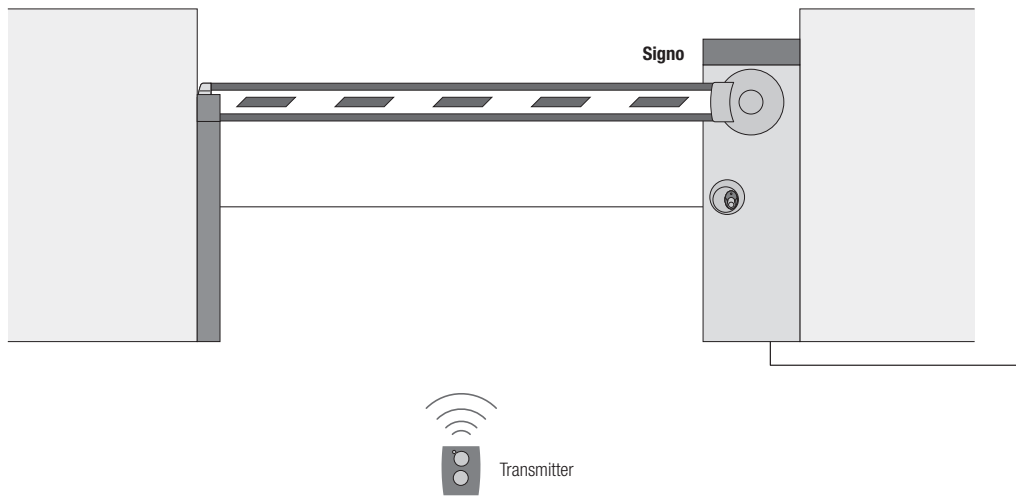

Approximate draft

#### Technical specifications

	<b>SIGNO4</b>	<b>SIGNO6</b>
Power (Vac 50/60 Hz)		230
Emergency power supply		PS224
Power absorbed (W)		300
Current absorbed (line) (A)		1.3
Current absorbed (motor) (A)		12
Protection level (IP)		44
Reduction ratio		1/241
Torque (Nm)	200	250
Min. ÷ max. opening time (s)	3÷6	6÷10
Working temp. (°C Min/Max)		-20 ÷ +50
Work cycle (%)		80
Dimensions (mm)	320x1070x320	420x1070x340
Weight (kg)	50	58
Insulation class		1

#### Utilisation limits

**SIGNO6 up to 6 m**  
bar with complete set of accessories  
with limits to speed

**SIGNO4 up to 4 m**  
fully accessoried  
bar up to 3.75 m

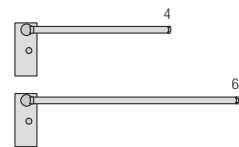

#### Bar lenght (m)

*N.B. Tubular aluminium bars  
don't need the use of accessories  
(only WA11).*

#### Dimensions

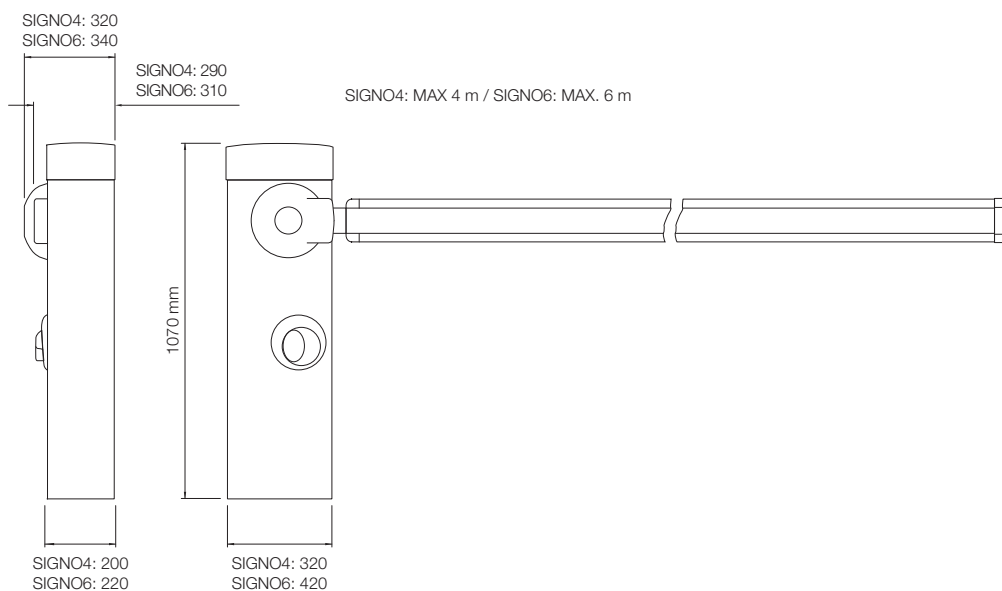

# Nice SignoKit

Bar length up to 4 m

## SignoKit 1

Square bar, including:

Nice Price £ 1,473.00



### SIGN04

electromechanical barrier for bars up to 4 m, irreversible 230 Vac, 24 Vdc motor, with galvanised steel painted case, supplied base plate  
1 pc



### WA1

aluminium bar, painted white  
36x73x4250 mm  
1 pc



### WA10

red adhesive reflector strips  
24 pcs



### WA11

adjustable stand for bars  
1 pc

## SignoKit 2

Round bar, including:

Nice Price £ 1,544.00



### SIGN04

electromechanical barrier for bars up to 4 m, irreversible 230 Vac, 24 Vdc motor, with galvanised steel painted case, supplied base plate  
1 pc



### WA3

tubular aluminium bar, painted white  
Ø 70x4250 mm, suitable where there are strong winds  
1 pc



### WA4

connection for the WA3 bar  
1 pc



### WA10

red adhesive reflector strips  
24 pcs



### WA11

adjustable stand for bars  
1 pc

Bar length up to 6 m

### SignoKit 3

Square bar, including:

Nice Price £ 1,849.00



#### SIGN06

electromechanical barrier for bars up to 6 m, irreversible 230 Vac, 24 Vdc motor, with galvanised steel painted case, supplied base plate  
1 pc



#### WA21

aluminium bar, painted white 36x94x6250 mm  
1 pc



#### WA10

red adhesive reflector strips  
24 pcs



#### WA11

adjustable stand for bars  
1 pc

### SignoKit 4

Round bar, including:

Nice Price £ 1,869.00



#### SIGN06

electromechanical barrier for bars up to 6 m, irreversible 230 Vac, 24 Vdc motor, with galvanised steel painted case, supplied base plate  
1 pc



#### WA7

tubular aluminium bar, painted white Ø 90x6250 mm suitable where there are strong winds, only with WA11  
1 pc



#### WA8

connection for the WA7 bar  
1 pc



#### WA10

red adhesive reflector strips  
24 pcs



#### WA11

adjustable stand for bars  
1 pc



automatic barrier



# Signo

Technische instructies NL

COMPANY  
WITH QUALITY SYSTEM  
CERTIFIED BY DNV  
=ISO 9001/2000=



ISTSG REV 00.01

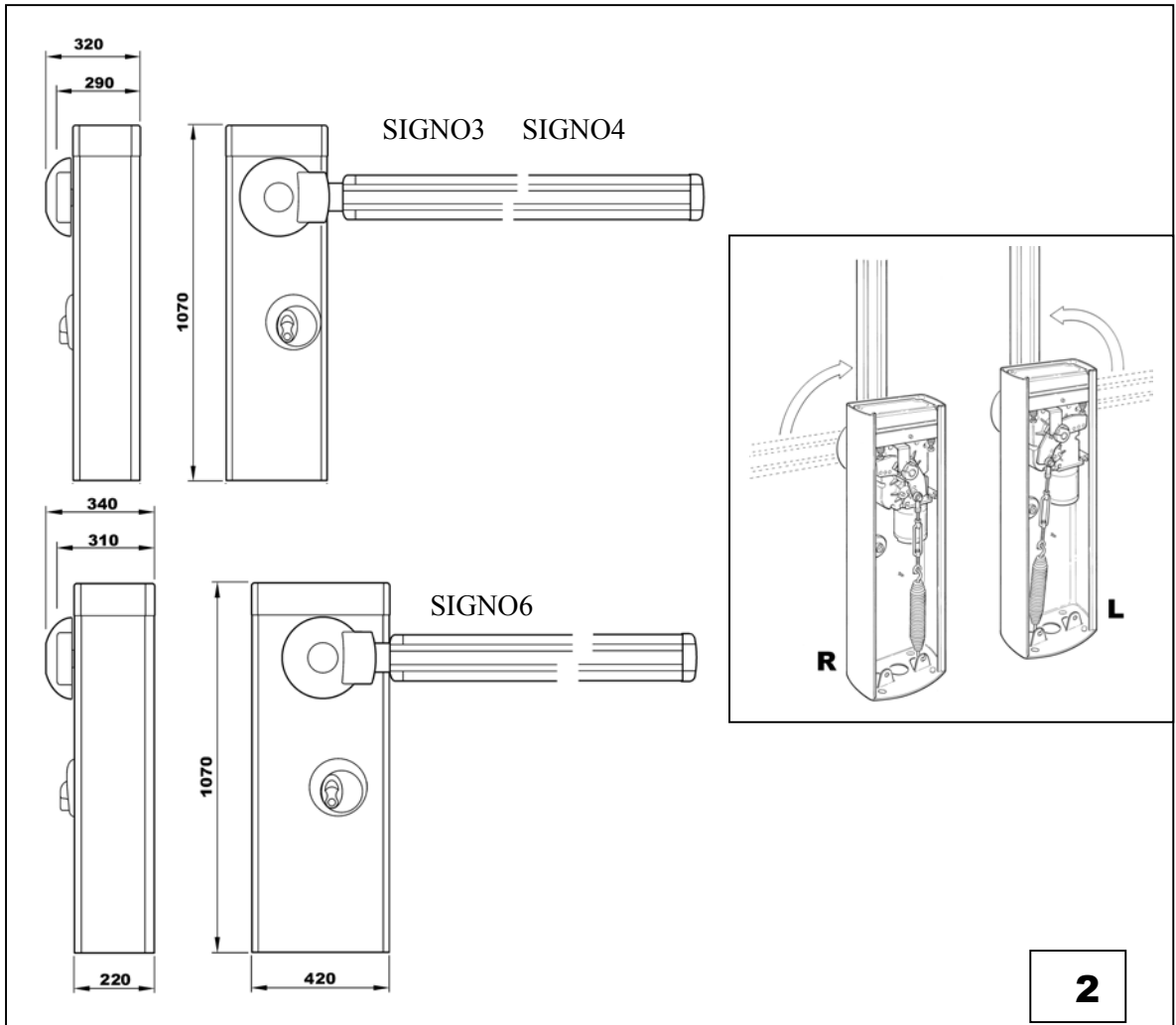
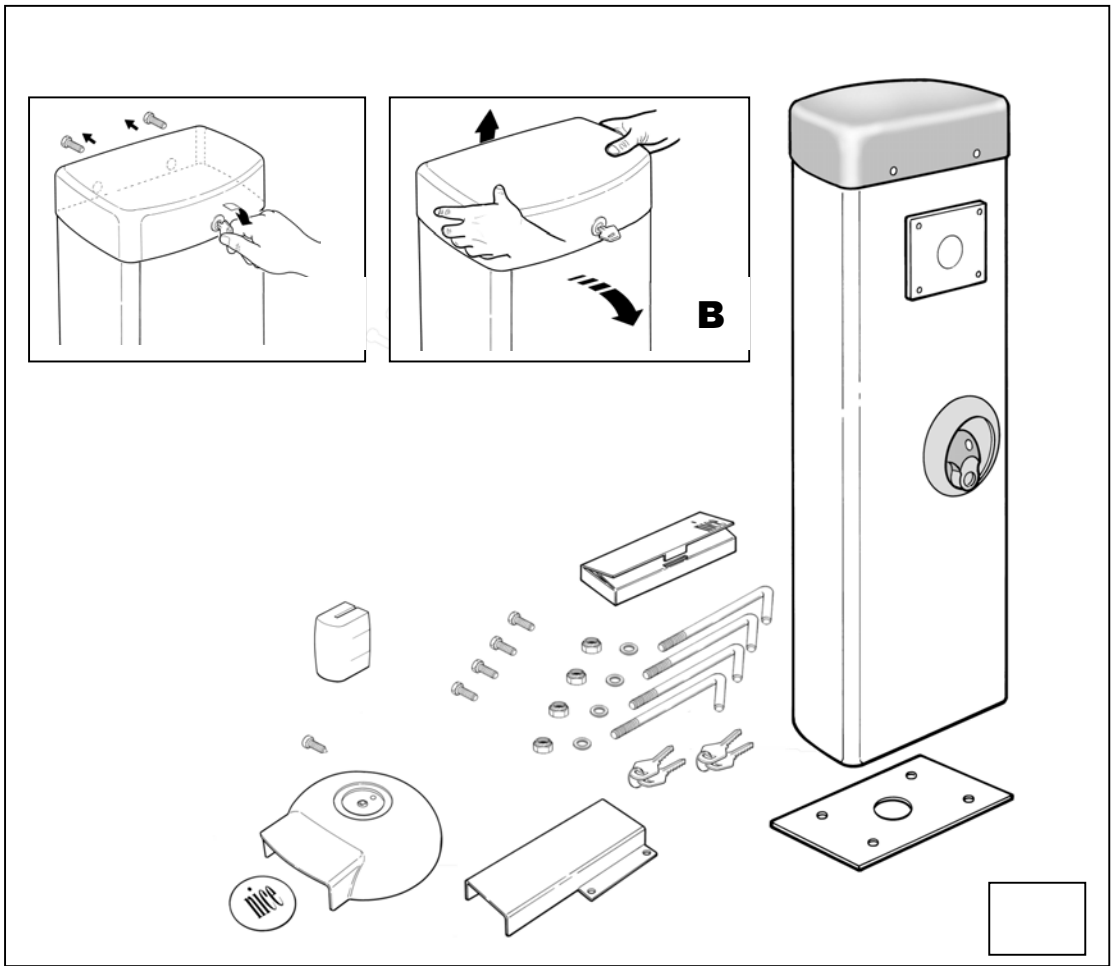

**2**

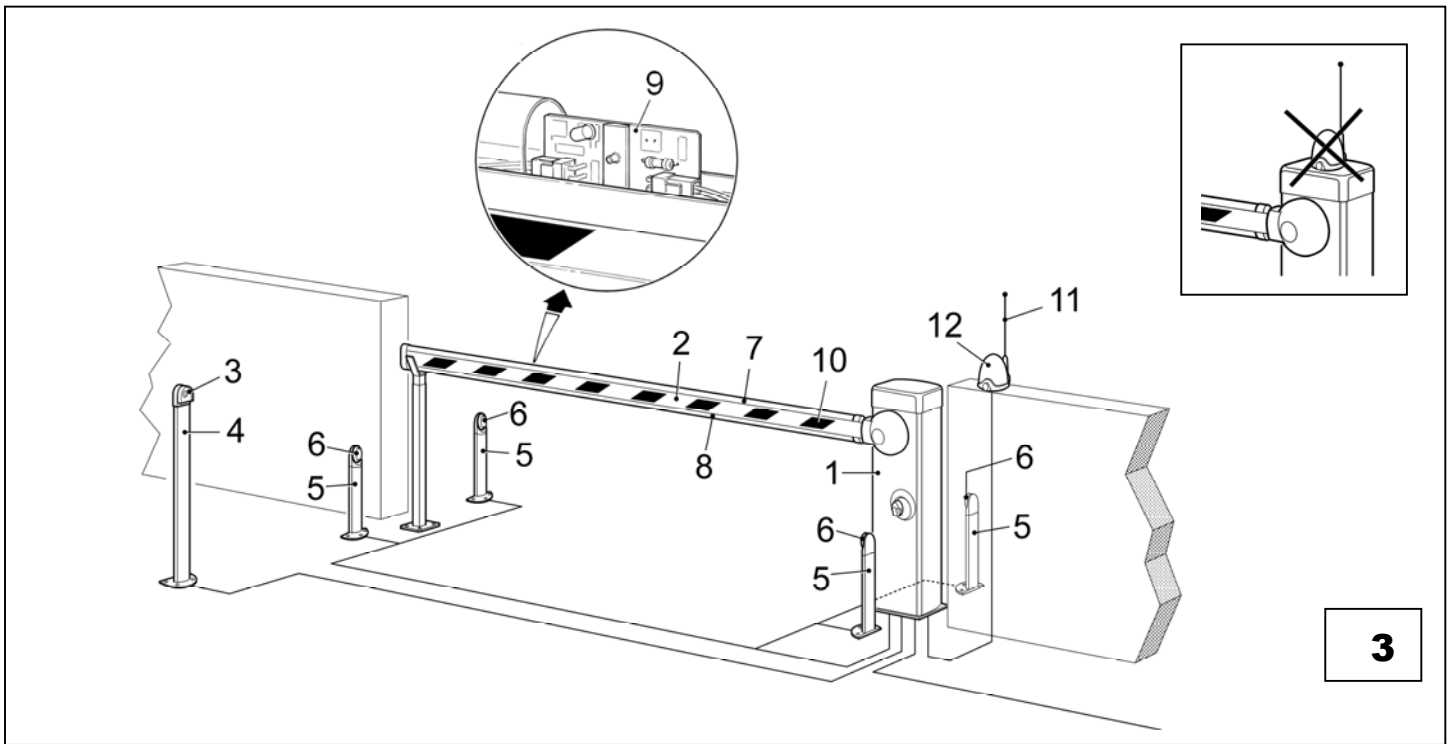

**3**

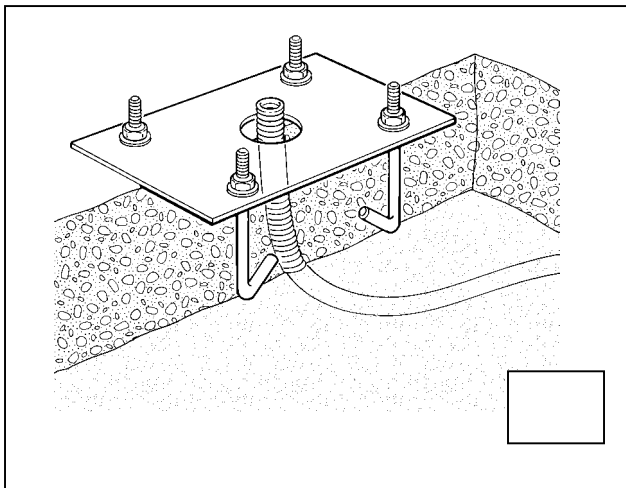

**4**

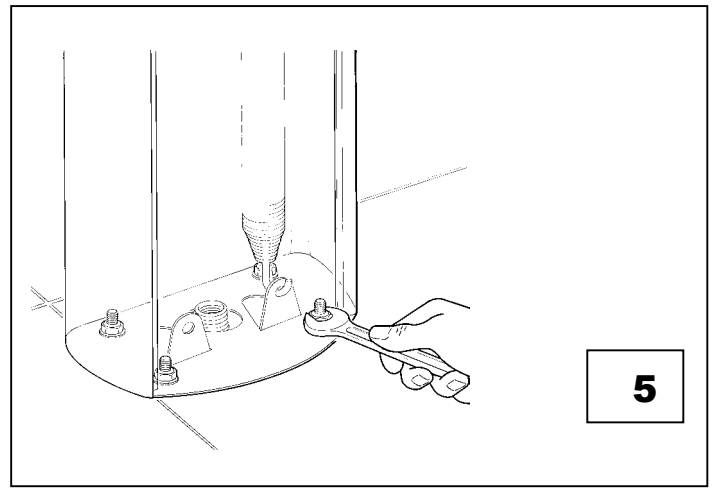

**5**

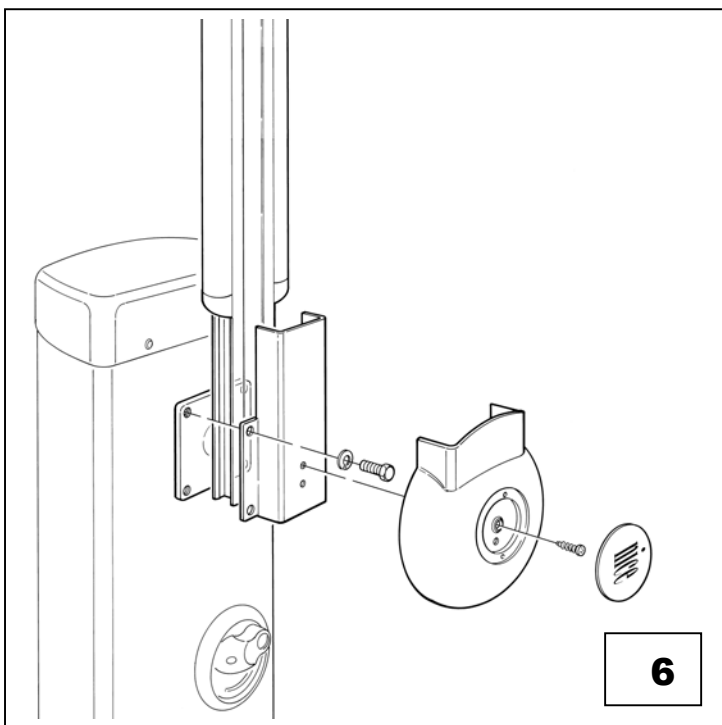

**6**

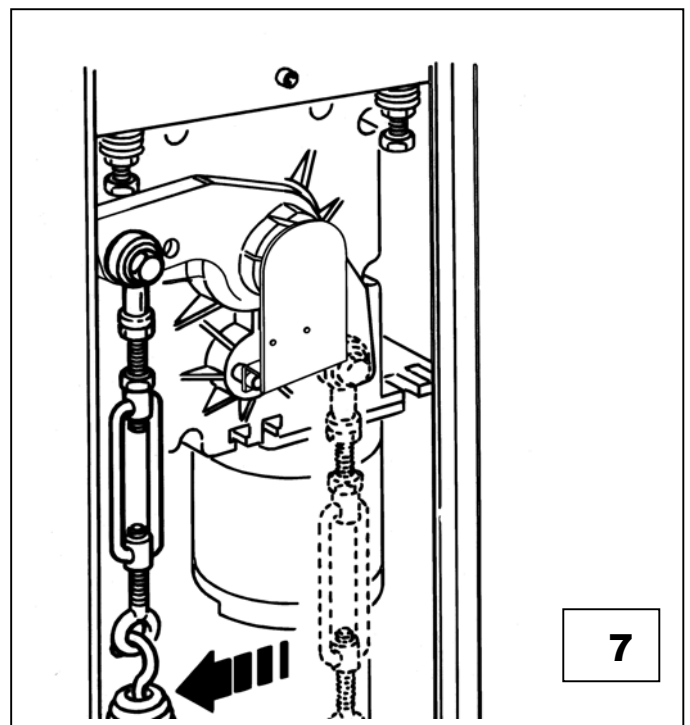

**7**

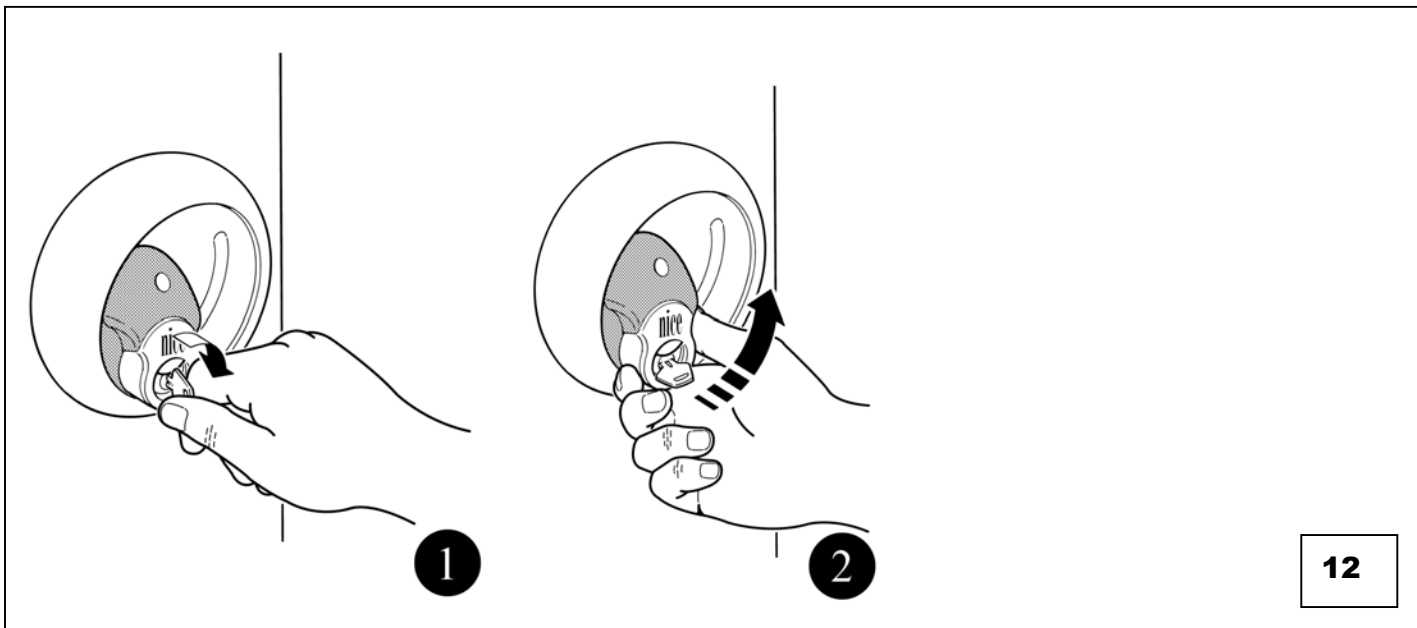
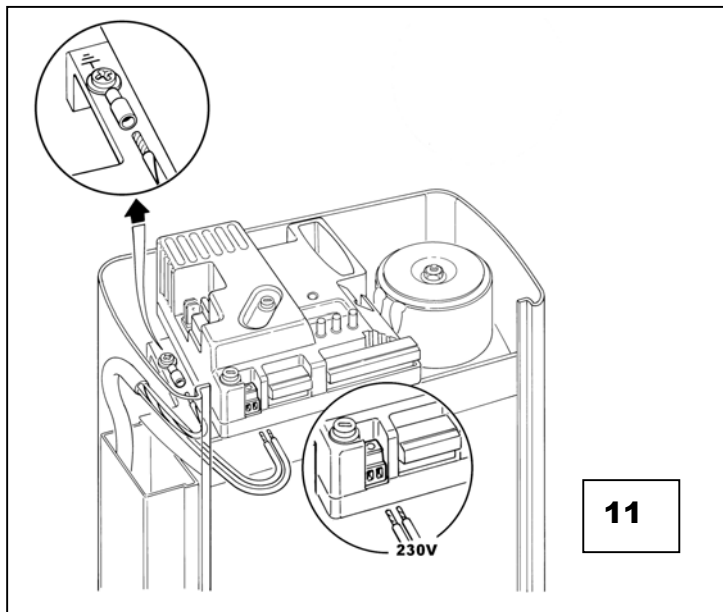
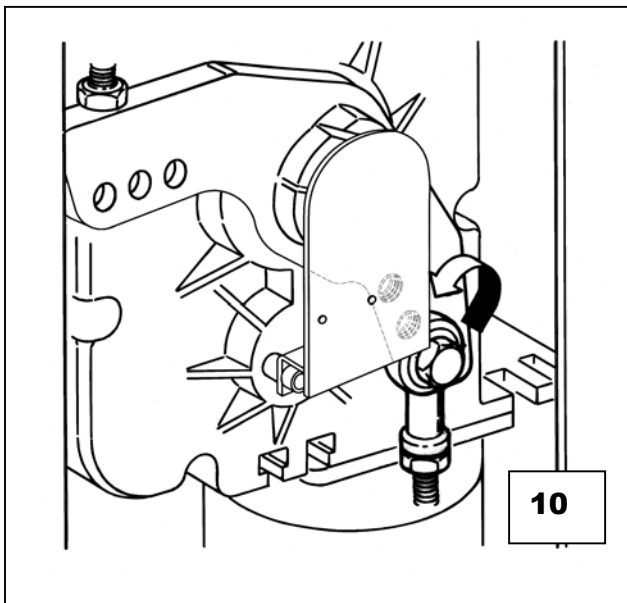
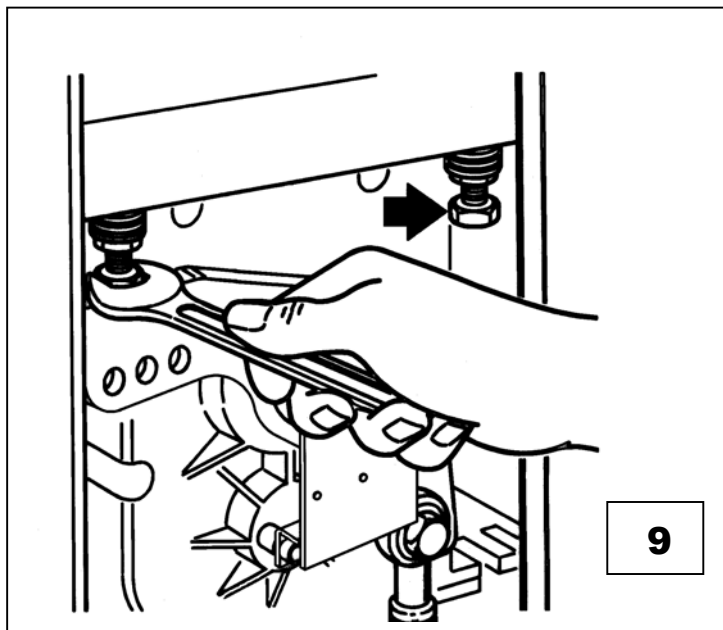
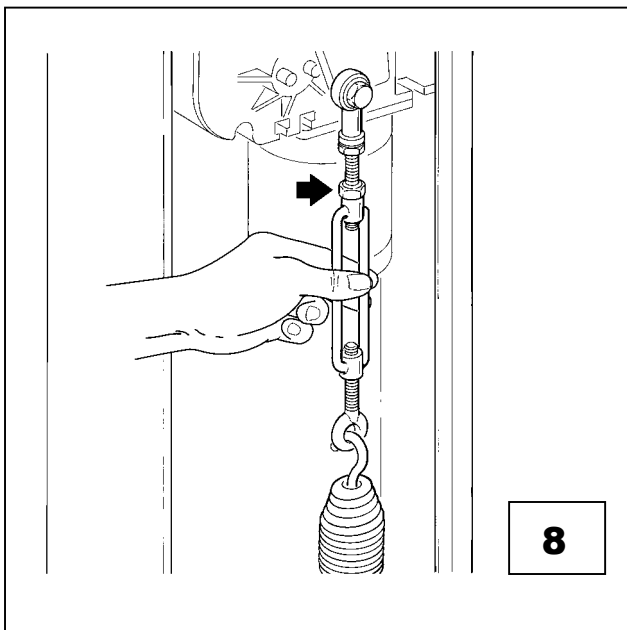

14	Warnings.....	26
15	Product description.....	26
15.1	Operating limits.....	27
16	Installation.....	27
16.1	Checks and preliminary operations.....	27
16.2	Typical system (fig. 3).....	28
16.3	Fixing.....	28
16.4	Connection to the power supply.....	28
16.5	Electrical diagram.....	29
16.6	Description of connections.....	30
16.7	Notes on electrical connections.....	30
16.8	Description of the Stop input.....	30
16.9	Phototest.....	31
16.10	Checking the connections.....	31
17	Programming and adjustments.....	32
17.1	Mechanical stops initial search.....	32
17.2	Mechanical stops automatic search.....	32
17.3	Manual programming of deceleration positions.....	33
17.4	Save procedure.....	33
17.5	Memory delete.....	34
17.6	Adjustments.....	34
17.6.1	Torque adjustment.....	34
17.6.2	Speed adjustment.....	34
17.6.3	Pause time adjustment.....	34
18	Testing and commissioning.....	35
19	Selectable functions.....	36
19.1	Functions description.....	36
20	What to do if.....	37
21	Manual or release manoeuvre.....	38
22	Maintenance.....	38
22.1	Planning of maintenance work.....	38
23	Disposal.....	40
24	Technical specifications.....	40
24.1	Control unit specifications.....	40
25	Accessories.....	41
25.1	RADIO receiver.....	41
26	Instructions and warnings for SIGNO barrier users.....	42

## 14 Warnings

Read these instructions before proceeding with the installation work. They contain important information regarding safety, installation, use and maintenance.

In order to make the use of these instructions as simple as possible, we have tried to follow the same order as the various phases of installation. All operations not specified in these instructions are not allowed; improper use may damage the product and endanger persons and property.

Store this manual safely for future use.

This manual, as well as the design and manufacture of the devices that make up SIGNO, comply fully with the standards and regulations in force.

Considering the hazards that may exist during the installation and operation of SIGNO, it is necessary that also the installation be carried out in strict compliance with current legislation, standards and regulations, particularly:

- Before you start with the installation, check whether additional devices or materials are needed to complete the automation with SIGNO based on the specific application requirements.
- The automation system must not be used until it has been commissioned as described in the heading: Testing and commissioning.
- The packing materials must be disposed of in compliance with local regulations.
- Do not make modifications to any components unless such action is specified in this manual. Operations of this type are likely to lead to malfunctions. NICE disclaims any liability for damage resulting from modified products.
- Do not immerse the automation parts in water or any other liquid. During installation, ensure that liquids do not leak into the control unit or other open devices.
- In the event that liquid substances have penetrated inside the automation devices, immediately disconnect the power supply and contact the NICE customer service department. The use of SIGNO in these conditions can be dangerous.
- Keep all components of SIGNO away from heat sources and open flames; these could damage the components and cause malfunctions, fire or dangerous situations.
- During long periods of inactivity, the optional battery should be removed and stored in a dry location to prevent leakage of noxious substances.
- Connect the control unit only to a power supply line equipped with safety grounding system.
- All operations requiring the opening of the door of the SIGNO device must be performed with the control unit disconnected from the power supply; if the disconnection device is not identifiable, affix a notice to the effect: "WARNING: MAINTENANCE WORK IN PROGRESS".
- In the event that any automatic switches are tripped or fuses blown, you must identify the fault and eliminate it before resetting the switches or replacing fuses.

If a fault occurs that cannot be solved using the information provided in this manual, refer to the NICE customer service department.

## 15 Product description

**SIGNO** is an electromechanical barrier operator including foundation plate, bracket for attachment of a rectangular section bar, and control unit.

The automation system is designed to reach its stroke limit positions (opening and closing strokes) with a deceleration phase, while monitoring motor load during the movement.

Thanks to these control systems any obstacles encountered in the range of the stroke are identified immediately causing reversal of the direction of movement (current sensor function). The system can be used in "manual", "semiautomatic" and "automatic" mode with functions such as "Close 0 sec. after Photo", "Always close" and two types of traffic light signalling. The control unit includes a cycles counter that allows management through time of system maintenance interventions, and it is also prearranged for inclusion of radio receivers with SM slot.

Optional accessories are available for all versions.

**SIGNO 3** . Serves to automate an access protected by means of a barrier bar of up to 3 m in length

**SIGNO 4** . Serves to automate an access protected by means of a barrier bar of up to 4 m in length

**SIGNO 6** . Serves to automate an access protected by means of a barrier bar of up to 6 m in length

## 15.1 Operating limits

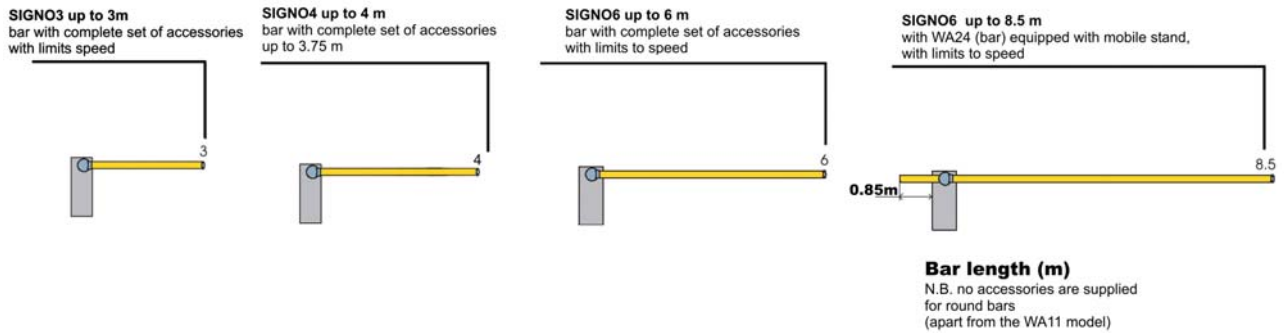

## 16 Installation

Note that automatic gate and door systems must be installed exclusively by qualified technical personnel in full compliance with statutory regulations. Before starting the installation work read the instructions in the following manual carefully.

### 16.1 Checks and preliminary operations

- Check that the package is intact. After removing the cover and the door, check that the pack contains all the parts shown in **Fig. 1**

No. 4 Anchors - M12  
No. 4 Washers  $\phi$  12 mm  
No. 4 Locknuts - M12  
No. 2 Screws - 4.2 x 9.5  
No. 1 Bar support bracket  
No. 1 Pair of keys for release procedure  
No. 1 Pair of keys for cover  
No. 4 Screws - M8 x 16  
No. 1 Foundation plate  
No. 1 Bar cover  
No. 1 Printed cap  
No. 1 Front cap

- Referring to **Fig. 2**, check that the fixing zone is compatible with the dimensions of the barrier. **Warning:** check whether the bar is to be installed on the right (**R**) or left (**L**)
- Check for the absence of obstructions that could impede movement of the bar during the opening and closing movements.
- Check that the supporting base for SIGNO is solid and suitably sized.
- Check that the barrier fixing zone is compatible with easy and safe operation.
- Make sure that the mounting positions of the various devices are protected from impacts and that the mounting surfaces are sufficiently sturdy.

## 16.2 Typical system (fig. 3)

- 1 . Signo
- 2 . Aluminium bar
- 3 . Key-operated selector switch
- 4 . Post for selector switch
- 5 . Post for photocells
- 6 . Photocell
- 7 . Red rubber protective strip
- 8 . Safety edge or red rubber strip
- 9 . Flashing signal lights
10. Red reflector strips
11. Aerial
12. Flashing light

## 16.3 Fixing

11. Embed the supplied foundation plate in a suitably sized concrete plinth. The plate must be flush with the surface of the plinth, perfectly level, and with the exposed surface perfectly clean, taking care not to damage the thread of the anchor fixings and providing the facility for at least one or more ducts for the routing of electrical cables.  
**Warning:** the plate must be parallel to the bar. **Fig. 4**
12. Place SIGNO on the previously installed base and secure it with the supplied screws and washers. **Fig. 5**
13. If necessary, invert the position of the spring, moving it from the right to the left. Warning: the bar will be positioned vertically when the spring is in its relaxed position. **Fig. 6**
14. Fit the bar with the specific bracket supplied and secure it by tightening the 4 screws. **Fig. 7**
15. Perform the release procedure (see chapter 8 "Manual or release procedure")
16. Bring the bar to its horizontal position and fit any optional accessories required.
17. Balance the bar by means of the spring adjuster tension rod. The bar can be considered to be properly balanced when, positioned at an angle of 45°, it neither tends to descend nor move upwards. **Fig. 8** **WARNING:** once the balancing procedure is terminated tighten the tension rod nuts.
18. Horizontal and vertical linear alignment can be adjusted by means of the travel limit cushioning devices **Fig. 9**
19. Relock the barrier by performing step 5 in reverse.
20. If the SIGNO accessories are not used or only certain accessories are used, the balancing procedure can be facilitated by fixing the spring in one of the available holes **Fig. 10**

## 16.4 Connection to the power supply

Connect the 230V supply cable directly to the terminal. **Fig. 11**  
Secure with the specific cable clamp.

## 16.5 Electrical diagram

The following figure shows the layout of the electronic board with an indication of the main components and the wiring connections.

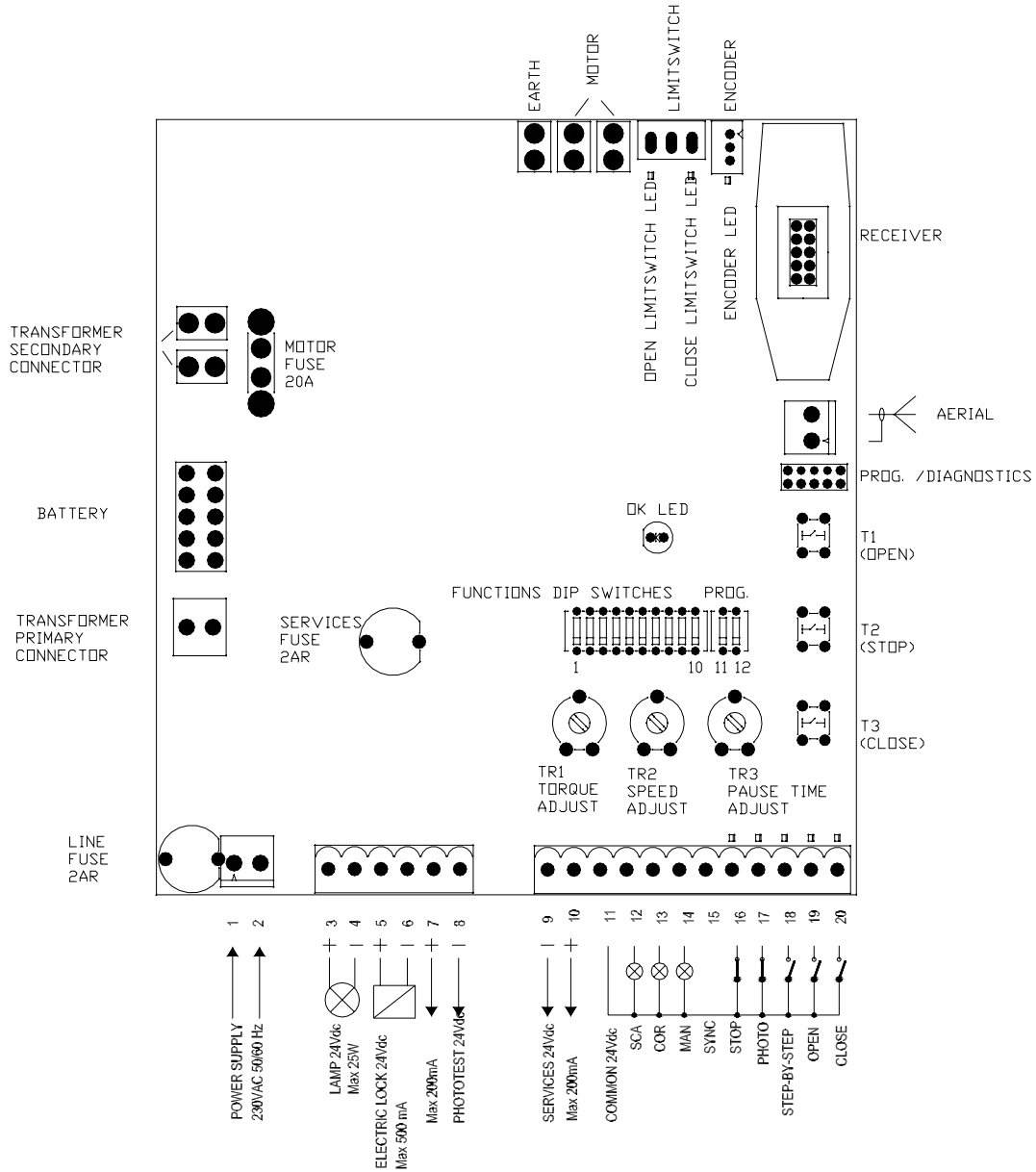

## 16.6 Description of connections

1-2	Phase - Neutral	= Mains power supply
3-4	Flashing light	= 24 Vdc max 25W flashing light output
5-6	Electric lock/Suction cup	= 24Vdc max 250 mA electric lock/suction cup output
7-8	Phototest	= Phototest output
9-10	24 Vdc	= 24 Vdc max. 200mA services power supply
11	Common	= Common for all inputs
12	Sca	= Barrier open output (LED on = barrier open; LED off = barrier closed; high frequency flashing = closing phase; low frequency flashing = opening phase)
13	Cor	= Courtesy light output (activated at the start of a cycle and remains active for 60 seconds after the cycle is concluded)
14	Man	= Maintenance LED output
15	Sync	= Barriers synchronism
16	Stop	= STOP input (Emergency, trip, or extreme safety), normally closed type (NC) or constant 8.2K $\Omega$ resistance type (heading 0)
17	Foto	= NC type input for safety devices (Photocells, pneumatic safety edges) operational during the closing phase
18	Step-by-Step	= Input for cyclic Open – Stop – Close – Stop operation
19	Open	= Input for opening movement with cyclic Open – Stop – Open – Stop operation
20	Close	= Input for closing movement with cyclic Close – Stop – Close – Stop operation
	Aerial	= Input for radio receiver aerial
	Battery	= Connection of plug-in card for battery charger

## 16.7 Notes on electrical connections

To ensure the safety of the operator and prevent damage to components, while making connections or plugging in the radio receiver the control unit must be disconnected from the mains power supply and the back-up batteries (if present).

**To make the connections refer to the electrical diagram in heading 16.5, taking account of the following:**

- The control unit must be powered via a 3 x 1.5mm<sup>2</sup> cable (phase, neutral and earth); if the distance between the control unit and earthing system is greater than 30 m an earth electrode must be installed in the immediate vicinity of the control unit
- To connect the flashing light and electric lock we recommend using a cable with minimum wire section of 1 mm<sup>2</sup>
- For connections of the safety low voltage part of the safety circuit use wires with a minimum section of 0.25 mm<sup>2</sup>; (use shielded cables if the length exceeds 30 m, connecting the shield to ground only on the control unit side).
- Pay attention to devices with obliged polarity (flashing light, electric lock, phototest, services, etc.).
- NC (normally closed) type inputs, when unused, must be jumpered with the "24 Vdc Common"; NO (normally open) type inputs, when unused, must be left open.
- Contacts must be strictly mechanical and free of any type of electrical potential; "PNP", "NPN", "Open Collector" etc. type switching inputs are not permitted.

## 16.8 Description of the Stop input

The control unit can be programmed to operate with two types of STOP input:

- NC type STOP input: for connection of devices with a normal closed output (factory setting).
- Constant resistance STOP: for connection of devices with a constant resistance output of 8.2K $\Omega$  (e.g. safety edges). In this latter case the control unit measures the resistance connected across the STOP input and the services common terminal and disables the manoeuvre when the measured value moves outside the range defined by 8.2K $\Omega$  +/- 50%.

## To program the STOP input:

4. Set the dip switches as shown

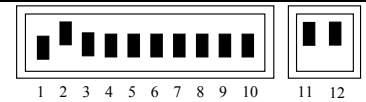

5. Execute the "save procedure" (heading 4.4), which in this case is required to save the status of the STOP input in teach-in mode.

6. Return the dip switches to the setting indicated

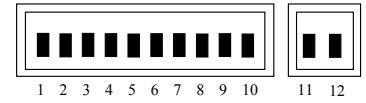

**Note.** When the programming procedure is terminated the STOP LED must remain illuminated to confirm that the data have been saved correctly.

## 16.9 Phototest

The Phototest function is an ideal solution in terms of reliability in relation to safety devices and it makes it possible to achieve "category 2" in compliance with UNI EN 954-1 (edition 12/1998), in relation to the combination of control unit and safety devices. To implement this solution connect the photocells as shown in the following diagram and set dip switch 7 to On (Phototest activation).

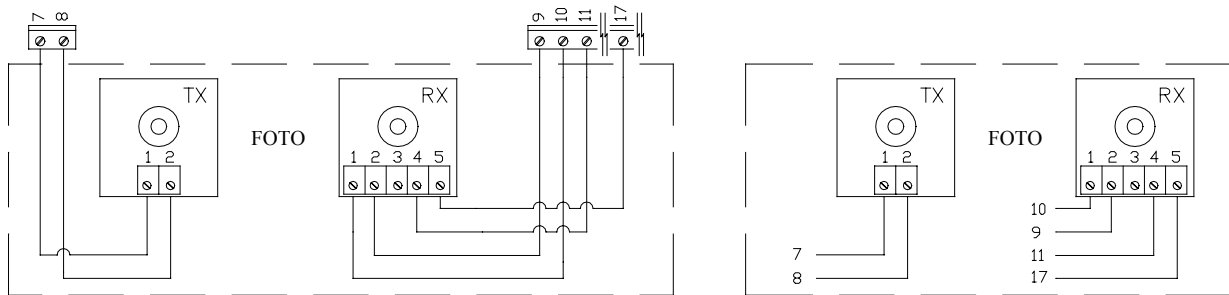

Whenever a manoeuvre is started all the safety devices are tested and the manoeuvre is effectively started only when the test gives positive results.

## 16.10 Checking the connections.

The following operations involve work being carried out on live circuits. Some parts carry mains voltage and are therefore extremely dangerous! Pay maximum attention to what you are doing and never work alone!

### **When you have finished making the connections it is good practice to perform a general check as follows:**

- Power on the control unit and immediately check for the presence of mains voltage on terminals 1-2 and between 28 and 33 volts on terminals 9-10 (services output). If the values do not correspond to the above specifications, disconnect the unit immediately and check the connections and power supply voltage carefully.
- Approximately 2 seconds after power-on the OK LED should start flashing at regular intervals of one second to indicate that the control unit is functioning correctly.
- Check that the LEDs relative to the STOP and Photo inputs are illuminated (safety devices active), while the LEDs relative to the step-by-step and open/close inputs must be extinguished (no command present); if this is not the case check the connections and ensure that the various devices are functioning correctly
- Check that all the safety devices in the system are functioning correctly (emergency stop, photocells, pneumatic safety edges, etc.); whenever the safety devices trip the relative STOP and Photo LEDs must switch off.
- Release the barrier and check that:
  - the bar is balanced – if it is not, adjust the balancing spring
  - the bar is free to move without undue resistance throughout the entire range of motion
  - the limit switches are functioning correctly: with the bar closed only the closed limit switch LED

---

must switch off; when the bar is open only the open limit switch LED must switch off; if this is not the case, disconnect the power supply and invert the limit switches connector

- ❑ leave the bar at an angle of approximately 45° so that it is free to move in the opening and closing directions, and then lock the barrier
- 
- Check that the bar moves in the correct direction, i.e.:
    - ❑ press the Close button and check that the bar moves in the closing direction
    - ❑ if the bar moves in the opening direction press the Close button again to stop the movement, then disconnect the power supply and invert the positions of two of the motor feeding wires
    - ❑ irrespective of the direction of movement of the bar, it is advisable to stop the movement immediately by pressing the Close button again
- 

## 17 Programming and adjustments

If the check performed on the various connections produces positive results, you can now start the mechanical stops search phase. This procedure is necessary because the SIA20 control unit must measure the distance travelled by the gear motor to bring the bar from fully closed (position 0) to fully open (position 1).

The mechanical stops search procedure can be performed using initial search mode or automatic search mode. Following the "initial search" or "automatic search", if you wish you can edit the RA and RC deceleration positions by means of a manual programming procedure.

**Position 0:** this is the point at which the bar is in the closed condition, corresponding to the closing stroke mechanical stop.

**Position RC:** this is the position at which the bar must start its deceleration phase during the closing manoeuvre.

**Position RA:** this is the position at which the bar must start its deceleration phase during the opening manoeuvre.

**Position 1:** this is the point at which the bar is in the fully open condition, corresponding to the opening stroke mechanical stop.

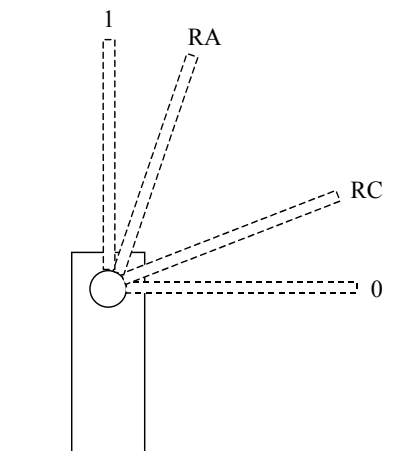

### 17.1 Mechanical stops initial search

The "mechanical stops initial search" procedure is executed automatically as the first manoeuvre following installation of the barrier.

#### To activate the mechanical stops initial search:

5. release the barrier, move it clear of the mechanical stops so that it is free to move in the opening and closing directions, and then lock the barrier
6. briefly press the Close button on the board or generate a command pulse on the inputs and wait for the control unit to perform a low speed closing manoeuvre to position 0, a low speed opening manoeuvre to position 1, and a high speed closing manoeuvre to position 0.  
**Note** if after transmitting the command the first movement is an opening manoeuvre, transmit a second command to stop the procedure and then invert the polarity of the motor feeding wires.
7. When the sequence described above is concluded, a mathematical operation is executed to calculate the deceleration positions (RA and RC) automatically.
8. The mechanical stops "initial search" procedure is now terminated and the gear motor is ready for use. Set up the "functions" dip switches as required.

**Note 1.** If one of the safety devices should trip or another command pulse is received during the "initial search" procedure, movement of the bar will be interrupted immediately; in this case the above procedure must be repeated starting from step 1.

---

### 17.2 Mechanical stops automatic search

As an alternative to the "Initial search" procedure the "Mechanical stops automatic search" procedure can be activated at any time without having to clear the memory. The procedure performs the mechanical stops

(positions 0 and 1) search procedure automatically using the same method as that described above for the "Initial Search" procedure.

**To activate the mechanical stops search**

7. Set up the dip switches as shown:

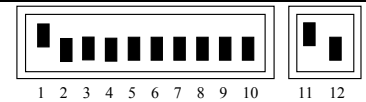

8. release the barrier, move it clear of the mechanical stops so that it is free to move in the opening and closing directions, and then lock the barrier

9. briefly press the Close button on the board and wait for the control unit to perform a low speed closing manoeuvre to position 0, a low speed opening manoeuvre to position 1, and a high speed closing manoeuvre to position 0.

**Note** if after transmitting the command the first movement is an opening manoeuvre, transmit a second command to stop the procedure and then invert the polarity of the motor feeding wires.

10. When the sequence described above is concluded, a mathematical operation is executed to calculate the deceleration positions automatically.

11. Return the dip switches to the positions shown:

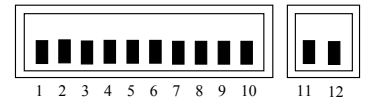

12. The mechanical stops "automatic search" procedure is now terminated and the gear motor is ready for use. Set up the "functions" dip switches as required.

**Note 1.** If one of the safety devices should trip or another command pulse is received during the "automatic search procedure", movement of the bar will be interrupted immediately; in this case the above procedure must be repeated starting from step 1.

**17.3 Manual programming of deceleration positions.**

This procedure involves the manual input of the positions for the start of deceleration as an alternative to the positions calculated automatically with the initial or automatic mechanical stops search procedure.

**To program the deceleration positions manually:**

5. Set up the dip switches in accordance with one of the following diagrams depending on the parameter to be saved

**POSITION RC:** Deceleration start position during the closing manoeuvre

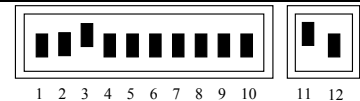

**POSITION RA:** Deceleration start position during the opening manoeuvre

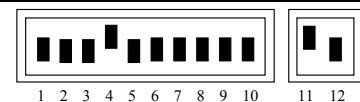

6. Press the Open or Close button on the board and hold it down until the required position has been reached.

**Note.** Press the Stop button if you wish to accelerate movement of the bar.

7. Once the position has been reached release the buttons and execute the "Save procedure" (heading 17.4)

8. Return the dip switches to the positions shown:

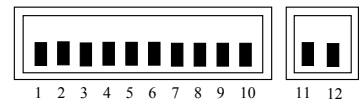

**17.4 Save procedure**

This operation serves to upload the value of the parameter you wish to program to the control unit permanent memory.

### To perform the save procedure:

4. Hold down the Stop button for at least 3 seconds, after which the OK LED will start flashing at high frequency
5. Release the Stop button. The OK LED will continue to flash at high frequency for a further 3 seconds.
6. Within three seconds press the Open and Close buttons simultaneously **and only momentarily**; when the two buttons are pressed simultaneously the OK LED will extinguish and then illuminate for 2 seconds to confirm that the selected parameter has been correctly saved in the memory.

## 17.5 Memory delete

All programmable parameters are recorded in a non-volatile memory that retains the information also in the event of a mains power loss; in certain cases it may prove necessary to remove all the data you have saved in this memory.

### To delete the contents of the memory:

4. Set the dip switches as shown:

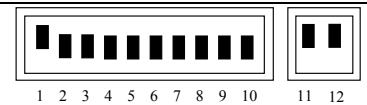

5. Execute the "save procedure" (heading 4.4), which in this case is required to confirm the delete procedure.

6. Return the dip switches to the setting indicated

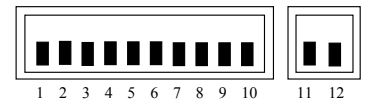

**Note.** When the memory has been reset the system assumes the same status as when the control unit has never been programmed so no movements will be possible; in this case the first command that is transmitted to the inputs or pressing either the Open or Close buttons serves to activate a "Mechanical stops initial search" procedure

**Note 1.** This operation does not delete the counter values for the number of manoeuvres executed and the number of manoeuvres programmed.

## 17.6 Adjustments

When the programming phase is terminated you can make the small number of indispensable adjustments necessary to ensure correct and safe operation of the automation system.

### 17.6.1 Torque adjustment

To limit the torque levels delivered by the transmission system in accordance with established standards, the control unit is equipped with a trimmer (TR1) that serves to adjust motor torque. Turn the trimmer clockwise to increase torque. If an obstacle is encountered during movement of the bar (motor torque demand higher than programmed torque), the system will stop and, if a semiautomatic or automatic movement was in progress a manoeuvre will be started in the opposite direction. To increase safety levels, if the detection of an obstacle occurs three times in succession before the bar has reached its correct closed position, the system will execute a brief inversion of travel direction and then stop.

### 17.6.2 Speed adjustment

To limit the kinetic energy of the bar in the event of impact with possible obstacles, apart from restricting motor torque it is also possible to reduce the speed of motion. The speed can be adjusted at any time by means of trimmer TR2: turn the trimmer clockwise to increase speed. When the trimmer is set to the maximum speed position barrier opening time is approximately 3 seconds; with the trimmer at its minimum speed position the opening time is approximately 6 seconds.

### 17.6.3 Pause time adjustment

When the automatic closing function is selected, after an opening movement a timer is triggered (pause time); when the timer interval elapses the close manoeuvre is started automatically. Pause time can be adjusted by means of trimmer TR3. With the trimmer in its minimum time position the pause time is 0 seconds; with the trimmer in the maximum time position (fully clockwise) the pause time is 120 seconds.

## 18 Testing and commissioning

This is the most important operation, designed to guarantee the maximum safety and reliability of the automation system. The testing procedure can also be used as a periodic check of the devices that make up the automation.

Testing of the entire system must be performed by qualified and experienced personnel who must establish which tests to conduct on the basis of the risks involved, and verify the compliance of the system with applicable regulations, legislation and standards, in particular with all the provisions of EN standard 12445 which establishes the test methods for automation systems for mixed vehicle and pedestrian transit road barriers.

Each component of the system, e.g. the emergency stop device, photocells, etc. may require a specific testing phase. We therefore recommend observing the procedures shown in the relative instruction manuals.

### Execute the following steps for the testing procedure:

---

3. Ensure that the instructions outlined in the "WARNINGS" chapter have been observed in full.

---

4. Set the dip switches as shown:  
(all functions disabled and semiautomatic operating mode)

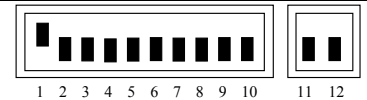

---

10. Press the Open button and check that:

- the flashing light is activated
- an opening manoeuvre is started with the acceleration phase
- the movement is decelerated and then stops when the bar is in the open position.

---

11. Press the Close button and check that:

- the flashing light is activated
- a closing manoeuvre is started
- the movement stops when the bar is closed.

---

12. Start an opening manoeuvre and check that tripping of a safety device connected to the:

- Stop input – causes immediate interruption of the movement
- Photo input – has no effect

---

13. Start a closing manoeuvre and check that tripping of a safety device connected to the:

- Stop input – causes immediate interruption of the movement
- Photo input – causes the movement to be stopped and restarted in the opposite direction

---

14. Engage a safety device connected to:

- the Stop input, and check that when a command input is activated the system does not execute any manoeuvres
- the Photo input, and check that when a close command input is activated the system does not execute the manoeuvre

---

15. During an opening or closing manoeuvre, impede movement of the bar with an obstacle and check that the gear motor performs a direction reversal before the torque level specified by applicable standards is exceeded.

---

16. Measure the impact force in accordance with the requirements of EN standard 12445 and, if control of "motor torque" is used to assist the system for the reduction of impact force, search for the setting that provides the best results

---

17. Check that the activation of the inputs (if connected) causes a step in the following sequence

- for the Step-by-Step input: Open – Stop – Close – Stop,
- for the Open input: Open – Stop – Open – Stop,
- for the Close input: Close – Stop – Close – Stop

---

18. Return the dip switches to the setting indicated

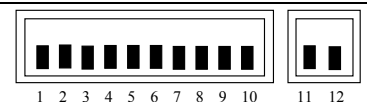

## 19 Selectable functions

To select the required functions set the programming dip switches to Off and activate the functions dip switches as shown in the following list:

Switch 1-2	Off Off	=	"Manual" movement, i.e. hand operated
	On Off	=	"Semiautomatic" function
	Off On	=	"Automatic" function, i.e. Automatic Closing
	On On	=	"Automatic + Always close" function
Switch 3	On	=	Condominium function <Not available in Manual mode>
Switch 4	On	=	5 s preflashing (2 s in manual mode)
Switch 5	On	=	Re-close 0 s after Photo if in automatic mode or re-close after Photo if in semiautomatic mode
Switch 6	On	=	Photo also during opening
Switch 7	On	=	Phototest activation
Switch 8	On	=	Suction cup
	Off	=	Electric lock
Switch 9	On	=	Traffic light in one-way mode
Switch 10	On	=	Traffic light in both directions

**Note.** Setting dip switches to the "Off" position servers to inhibit the associated function.

### 19.1 Functions description

#### Man Present Function

The movement is performed only when the command is present. The movement stops as soon as the command is suspended, when one of the safety devices trips ("Stop" or "Photo") or if the current sensor trips.

Once the manoeuvre has been interrupted the input command must be deactivated before another command can be transmitted to start a new movement.

#### Semiautomatic and automatic function

In "Semiautomatic" or "Automatic" mode following a command pulse the entire movement is executed until the specified position is reached. A second pulse on the same input that started the movement will cause a system Stop. If a control input is supplied with a continuous signal instead of a pulse, this will result in a priority condition wherein all the other control inputs are disabled (this function is useful, for example, if a clock is to be connected to the opening input). Tripping of the current sensor or a photocell involved in the direction of motion during a manoeuvre ("Photo" during the closing manoeuvre) will result in a direction reversal.

In Automatic operating mode, an opening manoeuvre will be followed by a pause and then a closing manoeuvre. If the "Photo" safety device trips during the pause interval, the timer will be reset with the preset pause time; if the "Stop" input trips during the pause interval the re-close function will be cancelled and the system will assume Stop status.

#### Always Close function

Automatically starts a close manoeuvre preceded by 5 seconds of preflashing if "bar open" status is detected when power is restored.

#### Condominium Function

In "Condominium" mode an opening manoeuvre cannot be interrupted by control pulses except for those that result in a closing manoeuvre. During the closing movement a new control pulse will cause the movement to stopped and reversed (opening movement).

#### Preflashing

A command impulse activates the flashing light, followed by movement 5 seconds later (2 seconds later in manual mode).

#### Re-close 0 seconds after Photo if in automatic mode or re-close after Photo if in semiautomatic mode

In automatic mode tripping of the photo safety device in the opening or closing manoeuvre reduces the pause time to 0 seconds irrespective of the preset pause time. In semiautomatic mode tripping of the photo safety device in the closing manoeuvre activates automatic closing with the preset pause time.

#### Photo also during opening

With this function tripping of the "Photo" safety device causes an interruption of the movement also during the opening manoeuvre; if the "Semiautomatic" or "Automatic" function is selected, after the "Photo" device is disengaged the opening movement will be resumed.

### Phototest activation

This function makes it possible to execute a check of the efficiency of all photocells at the start of every manoeuvre, thereby increasing the overall safety level of the system. For further details consult heading 16.9.

### Suction cup/electric lock

The function makes it possible to assign the following type of operation to the Electric lock output (terminals 5 and 6):

- electric lock (Switch 8 Off) – the output is activated for a few seconds in the opening manoeuvre with the bar closed
- suction cup (Switch 8 On) – the output is activated at the end of the closing movement and it remains activated for the entire time that the bar remains in the closed position.

### Traffic light in one-way mode.

In this mode the SCA output is active with the bar open and during the opening movement it remains switched on, while it is deactivated in the closing manoeuvre and with the bar closed. This makes it possible to connect a green traffic light to the output to signal free transit when illuminated.

### Traffic light in both directions.

Setting switch 10 to On, irrespective of the position of switch 9, serves to activate the function "Traffic light in both directions"; the following changes occur in the control unit: the "Open" input becomes "Step-by-Step 2", while the "Courtesy Light" (COR) and "Barrier open indicator light" (SCA) outputs become green traffic light for one direction and green traffic light for the opposite direction as specified in Fig. 5. For each direction of transit a different opening command is set: "Step-by-Step" (PP) to enter and "Step-by-Step 2" (PP2) to exit; in this case two traffic lights are installed with Red and Green signals, connected to the SCA and COR outputs.

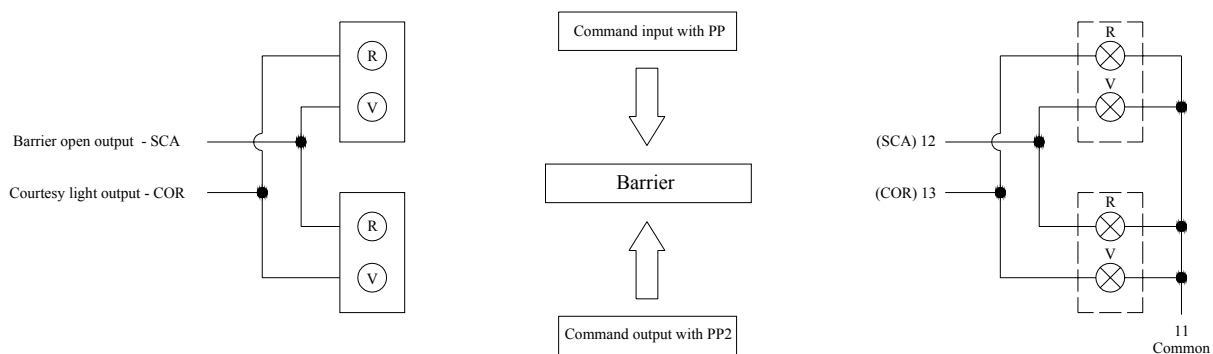

In normal conditions the SCA and COR outputs are switched off and consequently also the traffic lights are switched off; when a command is transmitted with PP to enter the protected area, the opening manoeuvre is started and simultaneously output SCA is activated and the green traffic light in the entry direction is activated together with the red traffic light in the exit direction.

On the contrary, if the command for opening is given by PP2 the COR output is activated to activate the green traffic light in the exit direction and the red traffic light in the entry direction. The light will remain illuminated for the entire duration of the opening phase and during the pause phase, if programmed; in contrast, during the closing phase the green and red lights will be illuminated together to signal that the transit priority situation is no longer valid.

The two outputs can be used to drive low power 24 Vdc lamps for a maximum of 10 W per output. If higher power lamps are required then it will be necessary to use relays driven by the control unit outputs to control the traffic lights.

## 20 What to do if...

The following section describes some of the more common problems that may be encountered during installation of the system.

- **No LED is on:**  
check for the presence of mains voltage on terminals 1 and 2 and ensure that fuses F1 and F3 are not blown.
- **The manoeuvre fails to start:**  
check that the Stop and Photo safety device input LEDs are active and the motor is locked (release LED extinguished).
- **A direction reversal occurs during the manoeuvre:**  
Check whether one of the safety devices has tripped (Photo during the closing manoeuvre) or whether the current sensor has tripped; in this latter case check that the current sensor setting is sufficiently high to

allow movement of the bar. If the value is insufficient increase the level by turning the torque trimmer (TR1) in a clockwise direction.

- **High frequency flashing of the OK LED:**  
the power supply voltage is insufficient or an incorrect combination has been selected on the dip switches.
- **The motor moves slowly:**  
the control unit is executing an alignment procedure; the first trip of the current sensor is interpreted as a mechanical stop.
  
- **The motor performs the acceleration phase and then stops:**  
check whether or not the encoder LED is flashing during movement of the motor. The flashing frequency may be higher or lower in relation to the speed of movement. With the motor at a standstill the LED may be On or Off, depending on the exact angular position at which the motor shaft has stopped.
- **OK LED steadily illuminated for a few seconds immediately after a command:**  
this indicates a fault in the motor control stage; check the wiring and ground insulation of the motor; if no problems are found, fit a new control unit.

## 21 Manual or release manoeuvre

**Warning: the release manoeuvre must be performed only when the bar is stopped.**

Manual operation **Fig. 12** must be adopted in the event of a power failure or in the case of system faults. The manual manoeuvre will allow free movement of the bar only if installed correctly and with genuine original accessories.

1. Lift the lock cover disk. Insert the key and turn it clockwise
2. Turn the release handle counter-clockwise. Move the bar manually

To lock the bar: return the release handle to its original position, turn the key and extract it.

## 22 Maintenance

Maintenance operations must be performed in strict compliance with the safety directions provided in this manual and in accordance with applicable legislation and standards. Although Signo does not require any special maintenance operations, regular inspections carried out at programmed intervals will ensure longer life of the system and reliable operation of the safety devices. For this purpose all the tests and checks specified in heading 4.1 "Testing" should be performed.

If other devices are installed, adhere strictly to the directions given in the relative maintenance plan.

<b>SIGNO 3</b>	Perform a periodic general inspection every 50,000 cycles
<b>SIGNO 4</b>	Perform a periodic general inspection every 6 months or 50,000 cycles
<b>SIGNO 6</b>	Perform a periodic general inspection every 6 months or 50,000 cycles

### 22.1 Planning of maintenance work

To assist planning of maintenance interventions for the entire system the control unit is equipped with a cycles counter that increases its value at each opening manoeuvre. The increase is signalled by a flash of the maintenance LED (MAN). The cycles counter value is constantly compared to an alarm threshold value (programmable by the system fitter) and checked against a warning threshold (set automatically at approximately 6 % below the alarm threshold). When the number of cycles executed exceeds the warning threshold the maintenance LED flashes only during manoeuvres of the barrier, while if the alarm threshold is exceeded this LED flashes constantly (when the motor is stopped and during movements) thereby signalling the urgent need for maintenance.

The alarm threshold can be programmed from a minimum value of 1000 to a maximum of 255000 cycles in multiples of 1000.

## To program the alarm threshold

7. Set the dip switches as shown

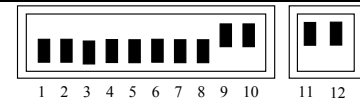

8. Divide the number of cycles to be programmed by 1000
9. In the following table find the combination of dip switches the sum of which is equivalent to the number you have just calculated and set the relative dip switches to On.

Dip switch	Sw1	Sw2	Sw3	Sw4	Sw5	Sw6	Sw7	Sw8
Pesi	1	2	4	8	16	32	64	128

**Example:** number of cycles to be programmed = 100,000  
Result after division: 100

$100 = 4 + 32 + 64$   
dip switches 3, 6 and 7 set to On

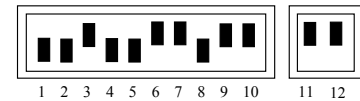

10. Execute the "Save procedure" (heading 4.4).
11. Return the dip switches to the setting indicated

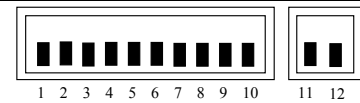

After you have set the alarm threshold you can display it to be sure that the operation you have just performed was successful.

## To display the alarm threshold

5. Set the dip switches as shown:

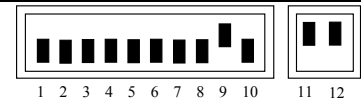

6. Set dip switch 1 to On (2,3,4,5 and 6 to Off), count the number of flashes of the OK LED and make a note of them (if there were 10 flashes note down 0)
7. Repeat the operation with dip switches 2, 3, 4, 5 and 6
8. Now recalculate the number of cycles as shown in one of the two examples given below

	Dip switch configuration							Number of cycles
		1 2 3 4 5 6	1 2 3 4 5 6	1 2 3 4 5 6	1 2 3 4 5 6	1 2 3 4 5 6	1 2 3 4 5 6	
Example: no. 1	Number of OK LED flashes	10	1	2	10	4	5	012,045
Example n° 2	Number of OK LED flashes	1	4	10	10	7	3	140,073

12. Return the dip switches to the setting indicated

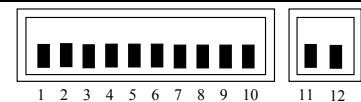

Use the same procedure to display the number of cycles executed;

## To display the number of cycles executed

4. Set the dip switches as shown:

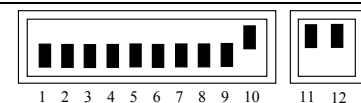

5. Re-count the flashes of the OK LED with dip switches 1,2,3,4,5 and 6 as shown in example 1 or 2.

**Note.** Whenever the warning threshold is programmed the value for the number of cycles executed is automatically deleted.

6. Return the dip switches to the setting indicated

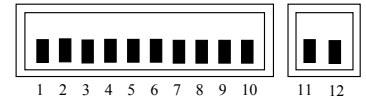

## 23 Disposal

SIGNO is constructed of various types of materials, some of which can be recycled (steel, aluminium, plastic, electric cables), while others must be disposed of (electronic boards and components).

**WARNING:** some electronic components may contain polluting substances; do not pollute the environment. Enquire about the recycling or disposal systems available in compliance with regulations locally in force.

6. Disconnect the automation system from the mains power supply.
7. Disassemble all the devices and accessories, following in reverse order the procedures described in chapter 16 “Installation”
8. Remove the electronic board.
9. Sort the various electrical and recyclable materials and consign them to licensed firms for recovery and disposal.
10. Consign the remaining materials to authorized scrap collection centres.

## 24 Technical specifications

	SIGNO 3	SIGNO3 V1	SIGNO 4	SIGNO4 V1	SIGNO 6	SIGNO6 V1
Power supply (Vac 50/60 Hz)	230	110	230	110	230	110
Emergency power supply (Vdc)	24					
Power draw (W)	250			300		
Line current input (A)	1.1	2.2	1.3	2.6	1.3	2.6
Motor current input (A)	10			12		
Transmission ratio	1/123			1/241		
Torque (Nm)	130			200		250
Min. – max. opening time (sec.)	1.8* ÷ 4			3 ÷ 6		6 ÷ 10
Operating temperature (C° Min./Max.)	20°÷ +50°					
Duty cycle (%)	80					
Protection rating	44					
Weight (kg)	50				58	
Insulation class	1					

\* Without installed accessories

### 24.1 Control unit specifications

Services output	:	24 Vdc, max. current 200mA (voltage can be between 17 and 35 Vdc)
Flashing light output	:	24 Vdc, max. power 25W (voltage can be between 16 and 35 Vdc)
Electric lock output	:	24 Vdc, max. current 250mA (voltage can be between 17 and 35 Vdc)
Phototest output	:	24 Vdc, max. current 200mA (voltage can be between 17 and 35 Vdc)
Courtesy light output	:	24 Vdc, max. power 10W (voltage can be between 17 and 35 Vdc)
Barrier open indicator light output	:	24 Vdc, max. power 10W (voltage can be between 17 and 35 Vdc)
Maintenance indicator light output	:	24 Vdc, max. power 10W (voltage can be between 17 and 35 Vdc)
STOP input:	:	for NC contacts or 8.2KΩ constant resistance +/- 50%
Pause time	:	from 0 seconds to 120 seconds
Courtesy light time	:	60 seconds
Max. cables length	:	power 30 m
	:	aerial 5 m

## 25 Accessories

	SIGNO	3	4	6
<b>SIA1</b>	Anchorage base with clamps	◆	◆	
<b>SIA2</b>	Anchorage base with clamps			◆
<b>SIA3</b>	Painted aluminium bar 36x73x3250 mm	◆		
<b>WA1</b>	Painted aluminium bar 36x73x4250 mm		◆	
<b>WA2</b>	Package containing 8 m of red impact-resistant rubber strip complete with closing caps for WA1 bar	◆	◆	
<b>WA3</b>	White painted tubular aluminium bar $\phi 70 \times 4250$ mm for applications in the presence of high wind shear exclusively with WA11		◆	
<b>WA4</b>	Attachment for bar WA3		◆	
<b>WA6</b>	Package containing 8 m of red impact-resistant rubber strip complete with closing caps for WA21 WA22 bar			◆
<b>WA7</b>	White painted tubular aluminium bar $\phi 90 \times 6250$ mm for applications in the presence of high wind shear exclusively with WA11			◆
<b>WA8</b>	Attachment for bar WA7			◆
<b>WA9</b>	Package of flashing signalling LEDs wired for bars WA1, WA21, WA22	◆	◆	◆
<b>WA10</b>	Red adhesive reflector strips	◆	◆	◆
<b>WA11</b>	Adjustable stand for bars	◆	◆	◆
<b>WA12</b>	Mobile stand for bars		◆	◆
<b>WA13</b>	2m aluminium rack for bars WA1, WA21, WA22.		◆	◆
<b>WA14</b>	Articulation for WA1 bars (from 1850mm to 2400mm)		◆	
<b>WA21</b>	Painted aluminium bar 36x73x6250 mm			◆
<b>WA22</b>	Modular bar ,plus joint painted white, 2 section 36x94x3125			◆
<b>WA24</b>	Tubular telescopic bar in white painted aluminium, max. length 8m, complete with mobile support WA12, counterweight and connector			◆
<b>PS224</b>	Buffer battery 24Vdc	◆	◆	◆
<b>SIA20</b>	Spare control unit	◆	◆	◆

### 25.1 RADIO receiver

The control unit is equipped with a connector for a radio receiver with SM slot (optional accessory) that makes it possible to activate the inputs as shown in the following table:

Receiver Output	Control unit input
no. 1	Step-by-Step
no. 2	Stop
no. 3	Open
no. 4	Close

## 26 Instructions and warnings for SIGNO barrier users



**Congratulations** for having chosen a Nice product for your automation system!

Nice S.p.A. produces components for the automation of gates, doors, rolling gates, roller shutters and awnings: gearmotors, control units, radio controls, flashing lights, photocells and miscellaneous accessories.

Nice uses only the finest materials and first-class workmanship. It focuses on the development of innovative solutions designed to simplify the use of its equipment, dedicating meticulous care to the study of its technical, aesthetic and ergonomic characteristics. From the wide range of Nice products, your installation technician will certainly have selected the one best suited to your specific requirements.

Note however that Nice S.p.a. is not the creator of your automation system, which is instead the end result of the analysis, choice of materials, and skilled work provided by your automation installation specialist.

Each automation system is unique, and only your installation specialist possesses the necessary experience and professionalism required to construct a system that matches your requirements perfectly and is safe and reliable through time, and above all reflects the axioms of sound engineering practice and is in full compliance with established standards and regulations.

An automation system is extremely convenient and a highly valuable addition to your security strategies, and, with a few simple precautions, will provide reliable service for the years to come.

Even if your automation system meets the safety levels imposed by current standards, this situation cannot eliminate the presence of possible "residual risks", i.e. the possibility of potentially hazardous situations, which are usually the result of negligent or even incorrect use of the system. That's why we wish to offer you a few tips on the correct actions to take to avoid all possible problems:

- **Before using your automation system**, ask your installation specialist to explain the origin of residual risks and take a few minutes to read the **user instructions and warnings manual** provided by your installer. Keep this manual safely for all future requirements and pass it on to the new owner of the automation system in the event of sale.

- **Your automation system is a machine designed to obey your commands with the utmost precision**; inappropriate or improper use of the system may give rise to safety hazards: do not operate the automation system if the movement could present a risk to persons, animals, or objects present within the operating range.

- **Children:** an automation system assures high levels of safety thanks to a series of sensing systems designed to prevent movements in the presence of persons and objects, guaranteeing safe and predictable movements at all times. Notwithstanding these design features, it is advisable to prevent children from playing around the area of the automation system and to keep remote controls out of children's reach to avoid involuntary activation of the system: **the automation system is not a toy!**

- **Faults:** As soon as you notice any form of anomalous performance of the automation system, disconnect the electrical power supply and execute the manual release procedure. Do not attempt to make repairs unassisted, always request the intervention of your automation installation specialist: in the meantime while awaiting the repair work the system can be used as a normal non-automated access, once the gear motor has been released as described further ahead.

- **Maintenance:** Like all machines, your automation system requires periodic maintenance to ensure it continues to function for the longest possible time in conditions of absolute safety. Arrange a maintenance plan with periodic servicing with your installation specialist; Nice S.p.a. recommends servicing be performed at 6 monthly intervals for normal residential uses, although this period may vary in relation to the intensity of use of the system. All inspection, maintenance and repair work must be carried out exclusively by qualified personnel.

- Even if you believe you are suitably qualified, do not attempt to modify the system or the programming and regulation parameters: the

responsibility for operations of this nature lies with your installation specialist.

- Final testing, periodic maintenance, and any repairs must be documented by the person responsible for them and the relative documentation must be kept in the custody of the owner of the automation system.

- **Disposal:** When the automation system reaches the end of its useful life ensure that it is dismantled by qualified personnel and that the materials of which it is made are recycled or disposed of in accordance with statutory local regulations.

- **In the event of breakdowns or power failures:** While awaiting the arrival of your installation specialist or for the electrical power supply to be restored if your system is not equipped with backup batteries, the automation system can be used in the same way as any normal non-automated access. To adopt this method of operation you must first execute the manual release procedure (this being the only "service" operation that the user is authorised to perform on the automation system): this operation has been specifically studied by Nice S.p.a. to guarantee the maximum ease of use without requiring tools or involving undue physical exertion.

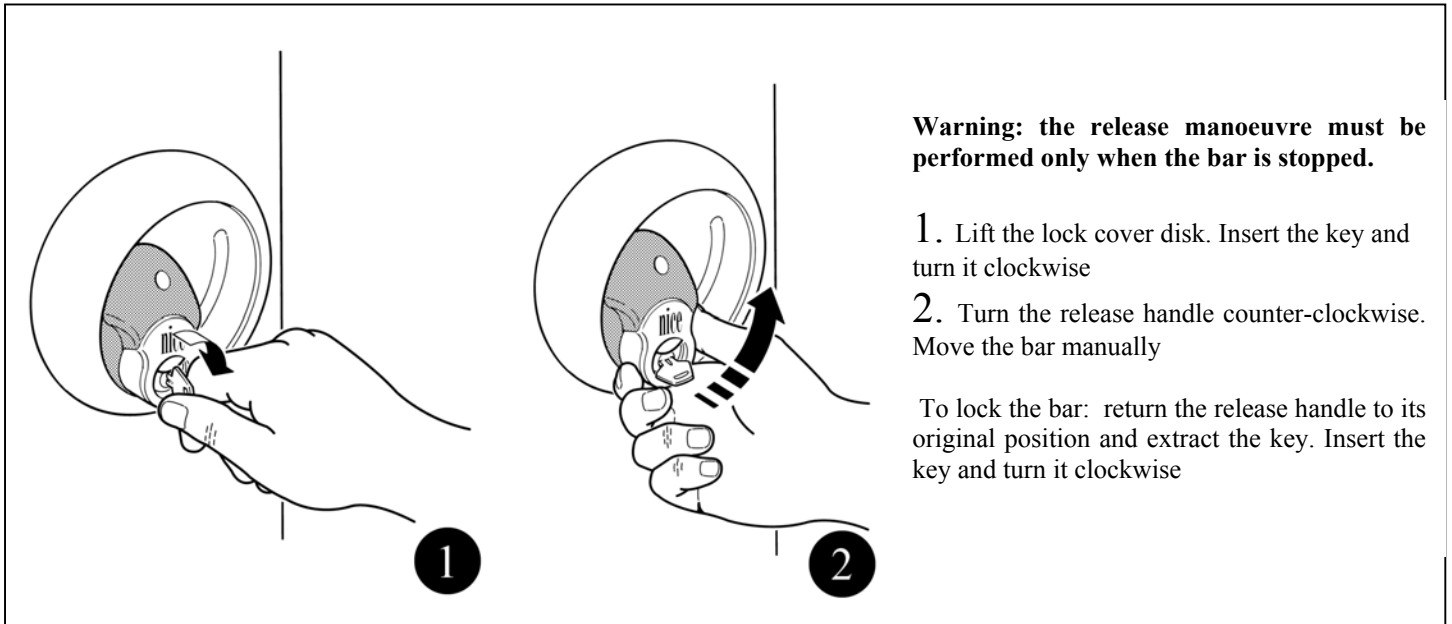

**Important:** if your automation system is equipped with a radio remote control that either becomes less efficient through time or even stops working altogether, the problem is likely to be simply a matter of a drained battery (depending on the type of unit the batteries may last for several months or up to two or three years). A sure sign of low battery power is when the transmission confirmation indicator light is dim, fails to illuminate, or illuminates only momentarily at intervals. Before consulting your installation specialist try switching the battery with the battery from another correctly functioning transmitter (if available): if this solves the problem then simply fit a new battery of the same type as the original.

**Are you satisfied?** If you wish to equip your home with a new automation system, when you entrust your requirements to your installation specialist and Nice S.p.a. you will receive the guarantee of all the necessary expertise and the most advanced automation products on the market, featuring unbeatable performance and seamless compatibility.

Thank you for taking the time to read these notes, we wish you the maximum satisfaction when using your new automation system: your installation specialist will be pleased to assist you for all present or future requirements.



Nice SpA  
Via Pezza Alta, 13  
Z.I. Rustignè I-31046  
Oderzo (TV) Italia

Phone +39 0422.853838  
Fax +39 0422.853585  
info@niceforyou.com  
www.niceforyou.com

P.IVA IT 03099360269  
C.F. / Reg. Impr.  
TV02717060277  
R.E.A. TV220549  
Mecc. TV042127



## Dichiarazione CE di conformità

Dichiarazione CE di conformità secondo Direttiva 98/37/CE, Allegato II, parte B  
(dichiarazione CE di conformità del fabbricante)

Numero: 179/SIGNO

Revisione: 1

Il sottoscritto Lauro Buoro in qualità di Amministratore Delegato, dichiara sotto la propria responsabilità che il prodotto:

Nome produttore : NICE s.p.a.  
Indirizzo : Via Pezza Alta 13, 31046 Z.I. Rustignè, Oderzo (TV) Italia  
Tipo : Motoriduttore elettromeccanico con centrale incorporata  
Modelli : SIGNO3, SIGNO4, SIGNO6,  
Accessori : Ricevente radio SMXI, SMXIS; batteria di emergenza PS224  
e tutti gli accessori di completamento previsti nel manuale di istruzione

Risulta conforme a quanto previsto dalla direttiva comunitaria:

- 98/37/CE (89/392/CEE modificata) DIRETTIVA 98/37/CE DEL PARLAMENTO EUROPEO E DEL CONSIGLIO del 22 giugno 1998 concernente il ravvicinamento delle legislazioni degli Stati membri relative alle macchine

Come previsto dalla direttiva 98/37/CE si avverte che non è consentita la messa in servizio del prodotto sopra indicato finché la macchina, in cui il prodotto è incorporato, non sia stata identificata e dichiarata conforme alla direttiva 98/37/CE.

Inoltre il prodotto risulta conforme a quanto previsto dalle seguenti direttive comunitarie, così come modificate dalla Direttiva 93/68/CEE del consiglio del 22 Luglio 1993:

- 73/23/CEE DIRETTIVA 73/23/CEE DEL CONSIGLIO del 19 febbraio 1973 concernente il riavvicinamento delle legislazioni degli Stati membri relative al materiale elettrico destinato ad essere adoperato entro taluni limiti di tensione
- 89/336/CEE DIRETTIVA 89/336/CEE DEL CONSIGLIO del 3 maggio 1989, per il riavvicinamento delle legislazioni degli Stati membri relative alla compatibilità elettromagnetica

Oderzo, 10 Giugno 2004

Lauro Buoro