



control units



mindy A01

Instructions and warnings for the fitter

Istruzioni ed avvertenze per l'installatore

Instructions et recommandations pour l'installateur

Anweisungen und Hinweise für den Installateur

Instrucciones y advertencias para el instalador

Instrukcje i uwagi dla instalatora

COMPANY
WITH QUALITY SYSTEM
CERTIFIED BY DNV
== ISO 9001 ==



Warnings:

The MINDY A01 control unit has been designed for the control of a single-phase asynchronous motor used for the automation of shutters, overhead garage doors, gates, rolling shutters or awnings. Any other use is improper and prohibited.

The motors must be equipped with electromechanical limit switches designed to limit their movement. Keep in mind that these automation systems must be installed by qualified personnel in compliance with current laws and regulations.

1) Product description

The Mindy A01 control unit enables the control of single-phase asynchronous motors powered by the electrical mains, with "COMMON" "OPEN" "CLOSE" type connections. It is designed for the automation of shutters, overhead garage doors, gates, rolling shutters or awnings. The control unit incorporates a radio receiver operating at a frequency of 433.92 MHz, which is compatible with the following types of transmitters:

Table "A1"	Transmitters
FLO	FLO1 - FLO2 - FLO4 VERY VE
FLOR	FLO1R - FLO2R - FLO4R VERY VR ERGO1 - ERGO4 - ERGO6 PLANO1 - PLANO4 - PLANO6
SMILO	SM2 - SM4

As the type of coding is different, the first transmitter memorized also determines the type of transmitters that may be memorized later. Up to 254 transmitters can be memorized.

After each command, the motor is powered for the "working time" (max 120 seconds) programmed during the installation stage.

An electric limit switch incorporated in the motor or automation system stops the movement when the desired position is reached. The control unit is equipped with a number of inputs used to activate commands such as "step-by-step", "open", "close", as well as signals for the triggering of security devices such as photocells or stop commands. The control unit can be connected to TTBUS systems. Management of the radio codes is facilitated by the use of the SMU programming unit.

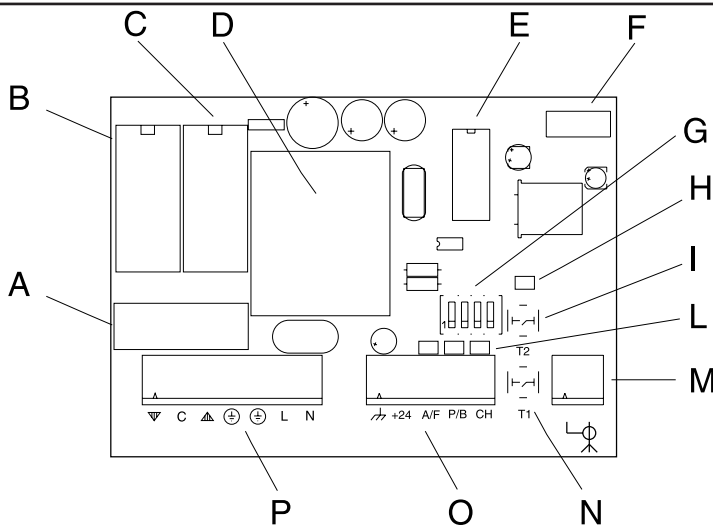

- A** Line fuse (5A)
- B** "close" relay
- C** "open" relay
- D** low voltage transformer
- E** microprocessor
- F** connector for SMU programmer
- G** programming dip-switch
- H** "radio" LED
- I** "radio" pushbutton
- L** inputs LED
- M** terminal for radio aerial
- N** "step by step" pushbutton
- O** low voltage input terminals
- P** line and motor connection terminals

2) Installation

⚠ The electrical systems and the automations must be installed by qualified and experienced personnel in compliance with current legislation. Before you proceed to make any connections make sure that the mains power supply is disconnected.

To proceed with the installation, secure the container as shown in figure 1.

When you drill a hole in the container for installation and wiring, take the necessary precautions to guarantee the required IP protection class. The wires must always be threaded from below.

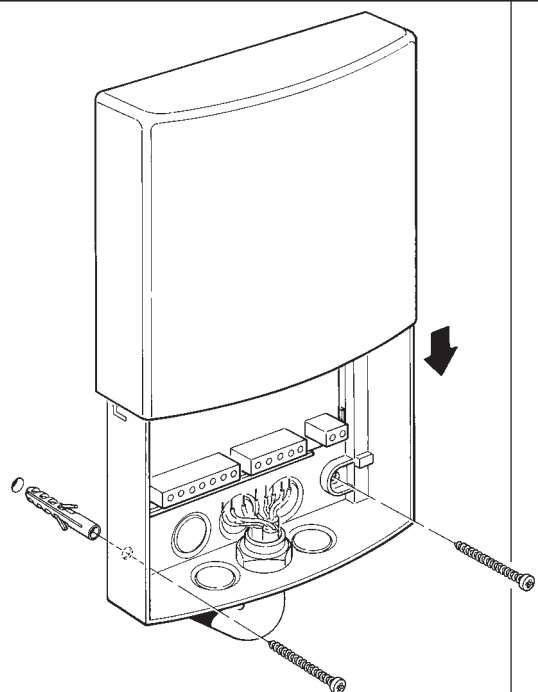

2.1.) Electrical connections

⚠ Warning: carefully follow all the connection instructions. If you have any doubts do not make experiments but consult the relevant technical specifications sheets which are also available on the web site www.niceforyou.com.

An incorrect connection may cause serious damage to the control unit. Do not connect multiple motors in parallel unless specifically required by the type of motor; if necessary, use the appropriate expansion cards.

2.1.1) Wiring diagram

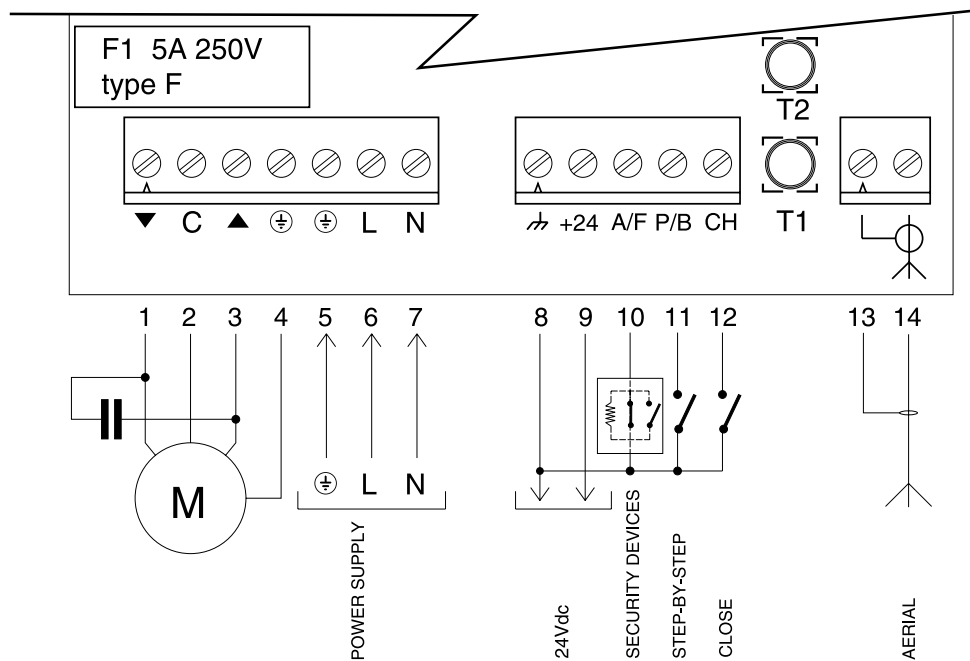

2.1.2) Description of the connections

Terminals	Function	Description
1-2-3-4	Motor	= motor control output (close, common, open, earth)
5-6-7	Power supply	= mains power supply line (earth, phase, neutral)
8-9	24Vdc	= 24Vdc output (services) max 50mA
10	Security devices	= input for security devices (STOP / PHOTOCCELL)
11	Step-by-step/Bus	= input for cyclic command (open-stop-close-stop) or TTBUS connection
12	Close	= input for closing command
13-14	Aerial	= radio receiver aerial input

2.1.3) Notes regarding connections

The control unit features two low voltage (24Vdc) supply terminals (8-9) for the services (photocell). Three additional terminals (10-11-12) are designated for the command and/or security inputs; as for the latter, the 0 volt terminal (8) is the common one. Some of these inputs have functions that depend on the programmed settings.

SECURITY DEVICES input

This input is designed for connection of the security devices. The input can be used with normally closed (NC) as well as normally open (NO) contacts or constant resistance contacts (8.2KΩ). To set dip-switches 3-4 based on the type of input used, refer to the “Programmable Functions” chapter. The LED by the input will light up to signal that the movement is enabled.

STEP-BY-STEP input

Each command on this input activates the open – stop – close – stop -..... sequence. In this mode, if the command is maintained for over 3 seconds (but less than 10), an opening manoeuvre will always be activated, if it is maintained for over 10 seconds, a closing manoeuvre will always be activated.

This function can be used to “synchronize” multiple control units, commanded in parallel, in the same direction regardless of their current status.

This input can be programmed as “open” (dip sw 2 ON). In this case, each command carries out the open - stop - close - stop - ... sequence.

The step-by-step input is also the TTBUS communication input. The “TTBUS” is a bus that has been developed for the management of control units for awnings, rolling shutters and motors with preset control unit. This Bus enables separate control of up to 100 control units by connecting them in parallel using only 2 wires. For further information, see the operating instructions for the remote controls via “TTBUS”.

CLOSE input

A command on this input always activates the close - stop - open - stop... sequence. This input is also used to activate automatic re-closing (with timed clock).



3) Programming

The control unit allows you to program the parameters and select the functions that are described below.

3.1) Programming the working time

The motor's working time can be programmed from a minimum of 5 seconds to a maximum of 120 seconds (factory setting or after total memory erasure). Once the working time has been programmed,

each command will activate the motor for the programmed length of time. To proceed with the programming process, follow the steps in the table below.

Table "A2"	Programming the working time	Example
1.	Press and hold down the T1 key on the control unit to start the motor	
2.	After holding down the T1 key for 5 seconds, start to memorize the time of the manoeuvre	 5s
3.	When you release the T1 key the motor will stop and the new working time will be programmed	

Note: If you wish to modify the working time, repeat the above procedure starting from step 1

The working time should be programmed to last a few seconds more than is strictly necessary for the completion of the manoeuvre.

3.2) Programmable functions

The control unit features 3 inputs that perform command and security functions. A four-contact dip-switch allows certain functions to be personalised in order to make the system more suitable to users' requirements.

Warning: Certain programmable functions are linked to security features; evaluate them carefully also based on the required security level.

Switch 1	Off	= SECURITY DEVICES input as "STOP" (short reversal and stopping of manoeuvre)
	On	= SECURITY DEVICES input as "PHOTOCELL" (causes reversal during closing manoeuvre)
Switch 2	Off	= STEP-BY-STEP input for "step-by-step" operation
	On	= STEP-BY-STEP input for "open" operation
Switch 3-4	Off Off	= SECURITY DEVICES input with NC contact
	On On	= SECURITY DEVICES input with NO contact
	Off On	= SECURITY DEVICES input with constant resistance contact 8.2K Ω
	On Off	= not allowed

3.3) Description of functions

Here is a brief description of the control unit's functions and behaviour based on the programmed settings.

Switch 1:

- off** = the SECURITY DEVICES input operates as a STOP input: without an enable signal, the movement is prevented and if the motor is already running a brief reversal is activated.
- on** = the SECURITY DEVICES input operates as a PHOTOCELL input: in the absence of an enable signal only the opening manoeuvre can be carried out. If the enable signal fails during the closing manoeuvre, a reversal and opening manoeuvre is carried out

Switch 2:

- off** = the STEP-BY-STEP input operates in "step-by-step" mode: each command activates the open-stop-close-stop sequence.
- on** = the STEP-BY-STEP input operates in "open" mode: each command activates the open-stop-open-stop sequence. This setting is useful if the input is used in conjunction with the CLOSE input and a selector switch enabling the independent activation of the opening and closing manoeuvres.

Switch 3-4: Used to select the type of contact that must exist between the common input and the SECURITY DEVICES input to enable the manoeuvre.

- off-off** = security devices with NC contacts
- on-on** = security devices with NO contacts
- off-on** = security devices with constant resistance 8.2 K Ω
- on-off** = not allowed

3.4) Memorizing the transmitters

The control unit recognizes various types of transmitters (see table A1); as the coding system is different, the first transmitter memorized determines the type of those that may be memorized afterwards. If you wish to change the type of transmitter, first you need to erase all the codes already stored in the memory.

You can check what type of transmitters are memorized in the control unit to see what type of transmitters can be added. To do this, check how many times the "radio LED" flashes when the control unit is switched on

The transmitters can be memorized directly through the T2 key on the card (this is necessary for the first transmitter), or using the remote memorization technique if the first transmitter code has already been stored.

Checking what type of transmitters are memorized	
1 "radio led" flash	FLO type transmitters memorized
2 "radio led" flashes	FLOR type transmitters memorized
3 "radio led" flashes	SMILO type transmitters memorized
5 "radio led" flashes	Empty memory (no memorized transmitter)

Either one of two modes can be used to memorize the transmitters:

mode I

In this mode, the function of the transmitter keys is fixed: key 1 commands the opening manoeuvre, key 2 commands a stop, key 3 commands the closing manoeuvre, and key 4 commands a stop. A single memorization stage is carried out for each transmitter; during this stage it does not matter which key is pressed, and only one space is occupied in the memory.

Example	memorization mode I
Key 1	OPEN
Key 2	STOP
Key 3	CLOSE
Key 4	STOP

Mode II

In this mode each transmitter key can be associated with one of the four commands available: "step-by-step", "open", "close", "stop". In this case each transmitter command to be activated must be memorized by pressing the desired key. Only one command can be associated with a key, whereas the same command can be activated using different keys. One space for each memorized key is occupied in the memory.



	A01 N°1	A01 N°2
Key 1	OPEN	
Key 2	CLOSE	
Key 3		OPEN
Key 4		CLOSE

	A01 N°1	A01 N°2	A01 N°3	A01 N°4
Key 1	STEP-BY-STEP			
Key 2		STEP-BY-STEP		
Key 3			STEP-BY-STEP	
Key 4				STEP-BY-STEP

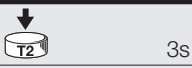
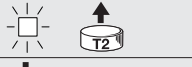
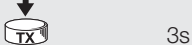
To proceed with the memorization of the transmitters refer to the following tables:

Table "A3"	memorization mode I	Example
1.	Press and hold down key T2 for at least 3 seconds	 3s
2.	When the "radio LED" lights up, release the key	
3.	Within 10 seconds, press any key on the transmitter to be memorized and hold it down for at least 3 seconds	 3s

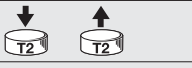
Note: If the memorization procedure has been successful the "radio LED" will flash three times. If you need to memorize additional transmitters, repeat step 3 within the next 10 seconds. The memorization procedure will be terminated if no new codes are received within 10 seconds.

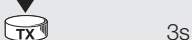
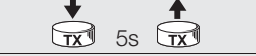

Table "A4"	memorization mode II	Example
1.	Press and release the T2 key as many times as the number corresponding to the desired function: 1 = "step-by-step" 2 = "open" 3 = "close" 4 = "stop"	
2.	Make sure that the "radio LED" flashes as many times as the number corresponding to the desired function	
3.	Within 10 seconds press the transmitter key you wish to memorize and hold it down for at least 3 seconds	 3s

Nota: If the memorization procedure has been successful the "radio LED" will flash slowly three times. If you need to memorize additional transmitters, repeat step 3 within the next 10 seconds. The memorization procedure will be terminated if no new codes are received within 10 seconds

3.5) Remote memorization

It is possible to enter a new transmitter in the memory of the control unit without using the T2 programming key directly. There must be a transmitter already memorized and operating. The new transmitter will "inherit" the characteristics of the previously memorized one. Therefore, if the first transmitter was memorized in mode I, also the new one must be memorized in mode I, and you can use any of the transmitter keys. If the first transmitter was memorized in mode II, also the new one must be memorized in mode II; in this case you must pay

attention to the keys you use on the 2 transmitters, since the key that you use on the new transmitter will perform the same function as the key pressed on the old transmitter. Before proceeding with the memorization operations you must read all the instructions and then perform all the operations one after the other without interruptions. Holding the two transmitters, the NEW one to be memorized and the OLD one already memorized, stand within the operating range of the remote controls and carry out the steps described in the table below.

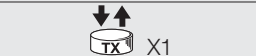

Table "A5"	Remote memorization	Example
1.	Press the key on the NEW transmitter for at least 5 seconds, then release it	
2.	Press the key on the OLD transmitter 3 times, slowly	
3.	Press the key on the NEW transmitter once, slowly, then release it	

Note: If there are other transmitters that need to be memorized, repeat all the steps described above for each new transmitter

3.6) Erasing from the memory

You can erase the memorized transmitter codes or the entire memory by restoring the control unit's factory settings. When all the transmitters have been erased, it is also possible to modify the type of transmitters that can be used.

To erase all the data contained in the memory follow the procedure described below:

Table "A6"	Erasing the memory	Example
1.	Press and hold down key T2 on the control unit	
2.	While holding down key T2, wait for the "radio LED" to light up, then wait until it goes off and then starts flashing	
3.	Release the key exactly at the third flash if you only wish to erase the transmitters, or exactly at the fifth flash in order to erase the entire memory	

Note: During the erasing procedure the "radio LED" will flash rapidly: 5 flashes will signal that the procedure has been completed. The deletion of all the data from the memory will also modify any programmed settings (working time, TTBUS address,...) and restore the control unit to the factory settings

4) Testing

When the connections have been made and all the programming operations completed you can proceed to test the system.

⚠ WARNING The testing procedure must be performed by qualified and experienced personnel, who must determine which tests are necessary based on actual risks.

The testing procedure is the most important aspect of the entire automation system set-up. Each single component, such as motor, emergency stop device, photocells etc., may require a specific testing

procedure. We recommend that you follow the procedures described in the relevant instruction manuals.

Particular attention must be dedicated to the installation of the motor, which must be equipped with electrical/mechanical limit switches designed to restrict its range of movement to the established travel limits. The motor limit switches must be adjusted before proceeding with the test.

The behaviour of the control unit depends also on the programmed functions. To test the system, proceed as described below.

1. Checking the direction of rotation

In some cases, the behaviour of the safety/security features depends on the direction of the manoeuvre. It is therefore important to make sure that the motor is connected properly.

- Give a movement command using the CLOSE input (terminal 12) and make sure that the automated device moves in the closing direction. If it moves in the opening direction, disconnect the power supply to the control unit and exchange the motor cables connected to terminals 1 and 3.

2. Checking the duration of manoeuvres

For a closing manoeuvre to be enabled, the input for the SECURITY DEVICES must give an OK signal, which is indicated by the lighting of the corresponding LED.

- Starting from a fully open condition, give a closing command. A few seconds after the completion of the manoeuvre, make sure that the closing relay opens.
- Give the command for an opening manoeuvre and make sure that the opening relay opens a few seconds after the completion of the manoeuvre. If the control unit's working times are not satisfactory, re-program the working time as described in chapter 3.1 "Programming the working time".

3. Testing the operation of the inputs

- Make sure that a command on terminal 11 (STEP BY STEP)
 - effects the following sequence: open-stop-close-stop (if dip-switch 2 is OFF)
 - effects the following sequence: open-stop-open-stop (if dip-switch 2 is ON)
- Make sure that a command on terminal 12 (CLOSE) always effects the sequence: close-stop-close-stop.

4. Testing the operation of the safety/security devices (if connected)

- Initiate a closing manoeuvre and make sure that, during the manoeuvre, the triggering of a device connected to input 10 (SECURITY DEVICES):
 - causes the immediate stopping of the movement with a brief reverse run (if dip-switch 1 is OFF)
 - causes the stopping and reversal of the manoeuvre (if dip-switch 1 is ON)
- Initiate an opening manoeuvre and make sure that, during the manoeuvre, the triggering of a device connected to input 10 (SECURITY DEVICES):
 - causes the immediate stopping of the movement with a brief reverse run (if dip-switch 1 is OFF)
 - has no effect (if dip-switch 1 is ON)

5. Testing the impact forces (if required by the type of automation system)

- Conduct the tests for the determination of the "impact forces" as provided by EN standard 12445

5) Optional accessories

The Mindy A01 control unit features a connector for connection to the SMU programmer. The programmer can be used to enter, erase, search for and copy the transmitter codes. Refer to the SMU programmer instructions for detailed information on how to use it.

⚠ Warning: the SMU programmer only enables the management of the radio control codes. The "read" and "write" functions alone can read and copy the entire contents of the memory of the control unit, therefore also the parameters and configurations (working time, TTBUS address...). When using these commands make sure that they are performed on compatible products.

6) What to do if...

The manoeuvre does not start even by operating the T1 key on the card.

Make sure that the card is properly powered and that the fuse is not blown. Between terminals 6 and 7 there must be mains voltage and between terminals 8 and 9 you must read a continuous voltage of approx. 24 Vdc.

You are unable to activate any manoeuvre and the LED for the SECURITY DEVICES flashes rapidly.

A short circuit and/or overload has probably occurred on the services outputs. The control unit is equipped with an automatic reset fuse; try disconnecting the power supply then wait a few seconds before reconnecting.

The power supply voltages are correct, yet the manoeuvre will not start.

The security devices input (STOP and PHOTOCCELL) must give its consent to the manoeuvre for it to be activated: make sure that the LED corresponding to the SECURITY DEVICES input is on.

Make sure that dip-switches 3-4 correspond to the type of input used. If the input is resistive type, the voltage reading between terminals 8 and 10 must range from 6Vdc to 18Vdc.

You are unable to memorize a new transmitter.

Make sure that the type of transmitter is compatible with those already stored in the memory. Switch the control unit off and then back on, and check the flashing of the "radio LED" to see what type of transmitters are already memorized.

The type of transmitter to be memorized is correct, but you are unable to memorize it.

Make sure that the card's receiving circuit operates properly: use a functioning transmitter. If the control unit correctly receives a radio code which is not, however, stored in the memory, it signals this condition with a flash of the "radio LED".

If you have already memorized the maximum number of transmitters (254), this event is signalled by 6 flashes.

7) Technical characteristics

Electronic control unit

Power supply:	: 230 Vac 50/60 Hz or 120Vac 50/60Hz depending on the version (see value on label)
Maximum motor power	: 600W for 230 Vac version; 400W for 120 Vac version
Command signal voltage	: approx. 24Vdc
Services (terminals 8-9)	: voltage 24Vdc \pm 30%; max current 50mA
Security input	: in the constant resistance configuration it must be $8.2K\Omega \pm 25\%\Omega$
Operating temperature	: -20 ÷ 50 °C
Dimensions / weight	: 118 x 52 x 147 350g
IP protection class	: 55

Radio receiver

Frequency	: 433.92 MHz
Coding	: FLO (fixed code), FLOR (rolling code) SMILO (rolling code)

Nice S.p.a reserves the right to modify its products at any time.



COMPANY
WITH QUALITY SYSTEM
CERTIFIED BY DNV
==ISO 9001==

Nice SpA Oderzo TV Italia
Via Pezza Alta, 13 Z.I. Rustignè
Tel. +39.0422.85.38.38
Fax +39.0422.85.35.85
info@niceforyou.com

Nice Padova Sarmeola I
Tel. +39.049.89.78.93.2
Fax +39.049.89.73.85.2
info.pd@niceforyou.com

Nice Belgium
Leuven (Heverlee) B
Tel. +32.(0)16.38.69.00
Fax +32.(0)16.38.69.01
nice.belgium@belgacom.net

Nice España Madrid E
Tel. +34.9.16.16.33.00
Fax +34.9.16.16.30.10
kamarautom@nexo.es

Nice France Buchelay F
Tel. +33.(0)1.30.33.95.95
Fax +33.(0)1.30.33.95.96
info@nicefrance.fr

Nice Rhône-Alpes
Decines Charpieu F
Tel. +33.(0)4.78.26.56.53
Fax +33.(0)4.78.26.57.53
info.lyon@nicefrance.fr

Nice Polska Pruszków PL
Tel. +48.22.728.33.22
Fax +48.22.728.25.10
nice@nice.com.pl

www.niceforyou.com