

Mindy

Control unit

CE

A6 - A6F
A700F

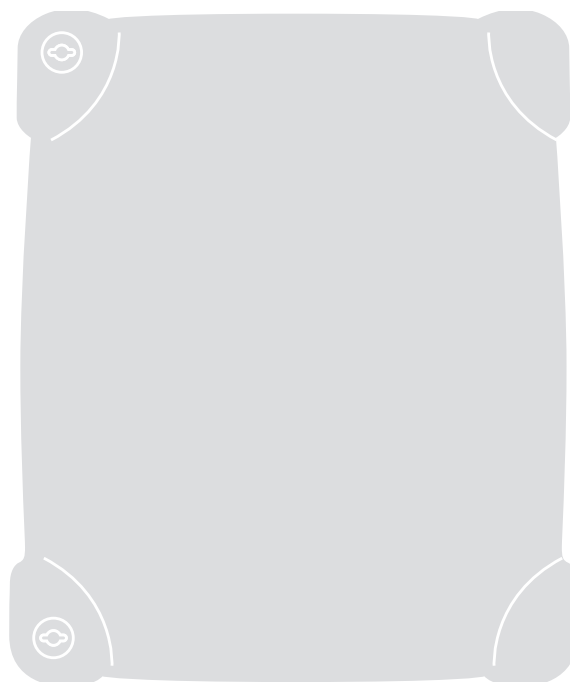

Instructions and warnings for the fitter
Istruzioni ed avvertenze per l'installatore
Instructions et recommandations pour l'installateur
Anweisungen und Hinweise für den Installateur
Instrucciones y advertencias para el instalador
Instrukcje i uwagi dla instalatora
Aanwijzingen en aanbevelingen voor de installateur

Mindy

A6 - A6F A700F

Index:	page				
1	Warnings	3	5	Programming:	9
2	Product description and applications	4	5.1	Programmable functions:	10
2.1	Operating limits	5	5.2	Description of the functions:	10
2.2	Typical system	5	6	Testing	12
2.3	List of cables	5	6.1	Commissioning	13
3	Installation	6	7	Maintenance and Disposal	13
3.1	Preliminary checks	6	7.1	Maintenance	13
3.2	Fixing the control unit	6	7.2	Disposal	14
3.3	Diagram of the connections:	6	8	Accessories	14
3.4	Description of the connections:	7	9	Technical characteristics	14
3.5	Notes about connections:	8			
4	Adjustments:	8			
4.1	Functioning modes:	9			

1) Warnings

This manual contains important information regarding safety. Before starting installation of the components, it is important that you read all the information contained herein. Store this manual safely for future use.

Due to the dangers which may arise during both the installation and use, installation must be carried out in full observance of the laws, provisions and rules currently in force to ensure maximum safety.

This chapter provides details of general warnings. Other more specific warnings are detailed in Chapters "3.2 Preliminary Checks" and "6 Testing and Commissioning".

⚠ According to the most recent European legislation, the automation of doors or gates is governed by the provisions listed in Directive 98/37/CE (Machine Directive) and, more specifically the standards: EN 13241-1 (harmonised standard); EN 12445; EN 12453 and EN 12635, which enables the declaration of machine conformity to the machine directive.

Visit "www.niceforyou.com" for further information and guidelines for risk analysis and how to draw up the Technical Documentation. This manual has been especially written for use by qualified fitters. Except for the enclosed specification "Instructions and Warnings for Users" to be removed by the installer, none of the information provided in this manual can be considered as being of interest to the end users!

- Any use or operation not explicitly provided for in these instructions is not permitted. Improper use may cause damage and personal injury.
- A risk analysis must be carried out before starting installation, including a the list of essential safety requisites provided for in Enclosure I of the Machine Directive, indicating the relative solutions employed. N.B. Risk analysis is one of the documents included in the "Technical Documentation" for this automation.
- Check whether additional devices are needed to complete the automation based on the specific application requirements and dangers present. The following risks must be considered: impact, crushing, shearing, dragging, etc. as well as other general dangers.
- Do not modify any components unless such action is specified in this manual. Operations of this type are likely to lead to malfunctions. NICE disclaims any liability for damage resulting from modified products.
- During installation and use, ensure that solid objects or liquids do not penetrate the control unit or other open devices. If necessary, contact the NICE customer service department; use in these conditions can be dangerous.
- The automation system must not be used until it has been commissioned as described in chapter 6 "Testing and commissioning".
- The packaging materials must be disposed of in compliance with local regulations.
- If a fault occurs that cannot be solved using the information provided in this manual, contact the NICE customer service department.
- In the event that any automatic switches are tripped or fuses blown, attempt to identify and eliminate the relative fault.
- Disconnect all the power supply circuits before accessing the terminals inside the cover. If the disconnection device is not identifiable, affix the following sign: "WARNING: MAINTENANCE WORK IN PROGRESS".

Special warnings concerning the suitable use of this product in relation to the 98/37/CE "Machine Directive" (ex 89/392/CEE):

- This product is issued on the market as a "machine component" and is therefore manufactured to be integrated in a machine or assembled with other machines in order to create "a machine", in accordance with the directive 98/37/EC, exclusively in combination with other components and in the manner described in the present instructions manual. As specified in the directive 98/37/CE the use of this product is not admitted until the manufacturer of the machine on which this product is mounted has identified and declared it as conforming to the directive 98/37/CE.

Special warnings concerning suitable use of this product in relation to the 73/23/EEC "Low Voltage" Directive and subsequent amendments 93/68/CEE:

- This product complies with the provisions envisaged by the "Low Voltage" Directive if used in the configurations foreseen in this instruction manual and in combination with the articles present in the Nice S.p.a. product catalogue. If the product is not used in the specified configurations or is used with other products that have not been foreseen, the requirements may not be guaranteed; use of the product is prohibited in these conditions until compliance with the requirements foreseen by the directive has been verified by installers.

Special warnings concerning suitable use of this product in relation to the 89/336/EEC "Electromagnetic Compatibility" Directive and subsequent amendments 92/31/EEC and 93/68/EEC:

- This product has undergone tests regarding electromagnetic compatibility in the most critical of use conditions, in the configurations foreseen in this instruction manual and in combination with articles present in the Nice S.p.A. product catalogue. Electromagnetic compatibility may not be guaranteed if used in configurations or with other products that have not been foreseen; use of the product is prohibited in these conditions until compliance with the requirements foreseen by the directive has been verified by installers.

2.1) Operating limits

Chapter 9 "Technical Characteristics" provides the only data needed to determine whether the products are suitable for the intended application.

2.2) Typical system

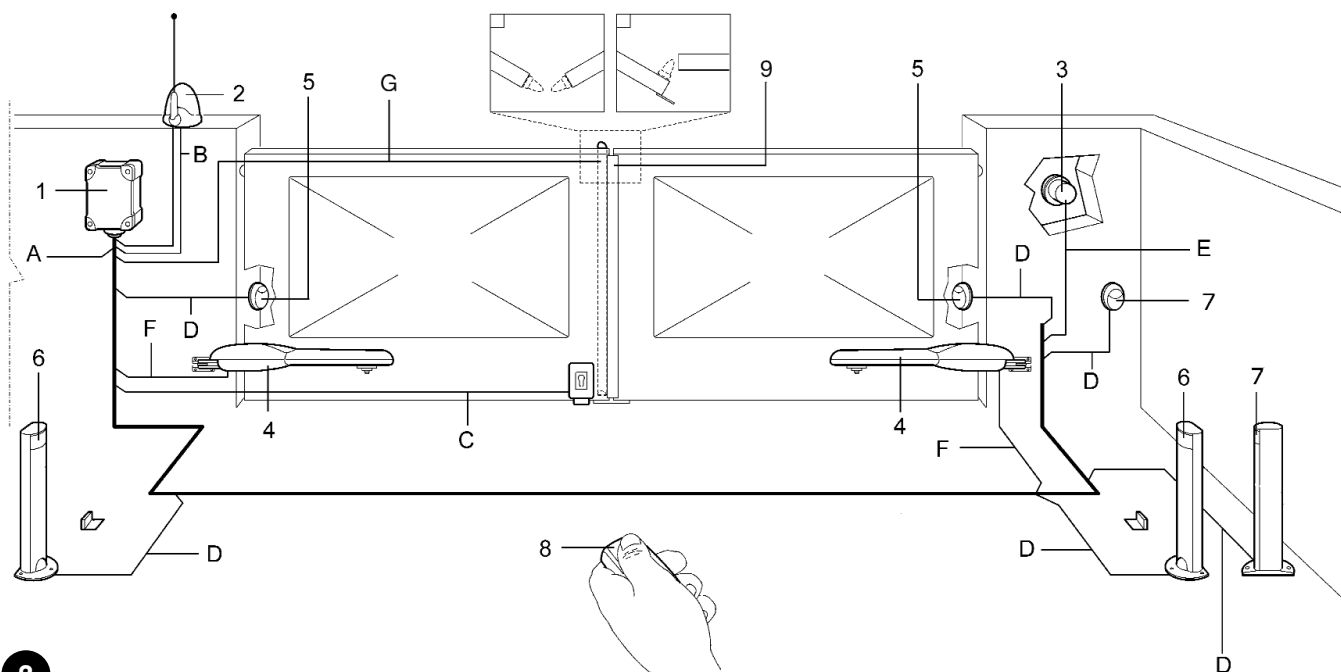

2

- | | |
|--|--|
| 1. Control Unit | 6. Couple of photoelectric cells PHOTO 1 |
| 2. Flashing light with incorporated aerial | 7. Couple of photoelectric cells PHOTO 2 |
| 3. Key-operated selector switch | 8. Radio transmitter |
| 4. Motors | 9. Sensitive edge |
| 5. Couple of photoelectric cells PHOTO | |

NOTE: This diagram only shows a possible application of the unit and should be considered merely as an example. Only an in-depth analysis of the risks of the "Machine" gate and a proper evaluation of the end user requirements will be able to establish how many and which elements must be installed.

2.3) List of cables

The typical system shown in figure 2 also states the cables required for connection of the various devices, the specifications of which are provided in table 1.

⚠ The cables used must be suitable for the type of installation; for example, an H03VV-F type cable is recommended for indoor applications, while H07RN-F is suitable for outdoor applications.

Table 1: List of cables

Connection	Cable type	Maximum admissible length
A: Electrical power line	N°1 cable 3x1,5mm ²	30m (note 1)
B: Flashing light with aerial	N°1 cable 2x0,5mm ²	20m
	N°1 shielded cable type RG58	20m (less than 5m recommended)
C: Electric lock	N°1 cable 2x1mm ²	20m
D: Photocells	N°1 cable 2x0,25mm ² (Tx)	30m
	N°1 cable 4x0,25mm ² (Rx)	30m
E: Key-operated selector switch	N°1 cable 4x0,25mm ²	30m
F: Connection to the motors.	N°1 cable 4x1,5mm ²	10m
G: Connection to sensitive edge	N°1 cable 2x0,25mm ²	30m

Note 1: power supply cable longer than 30 m may be used provided it has a larger gauge, e.g. 3x2,5mm², and that a safety earthing system is provided near the automation unit.

3) Installation

⚠ The installation must be carried out by qualified personnel in compliance with current legislation, standards and regulations, and the directions provided in this manual.

3.1) Preliminary checks

Before proceeding with the installation:

- Check that all the materials are in excellent condition, suitable for use and compliant with current standards.
 - Ensure that the structure of the gate is suitable for automation.
 - Ensure that the mounting positions of the various devices are protected from impact and that the mounting surfaces are sufficiently sturdy.
 - Install cable or pipe leads only at the bottom of the unit; for no reason whatsoever must the side and top walls be perforated. The cables must only enter the unit from the bottom!
 - Components must never be immersed in water or other liquids.
 - Keep away from heat sources and open flames; in acid, saline or potentially explosive atmosphere; this could damage A6 – A6F – A700F and cause malfunctions or hazardous situations.
- If there is an access door in the leaf, or within the range of movement of the gate, make sure that it does not obstruct normal travel. Mount a suitable interlock system if necessary.
 - Only connect the control unit to a power supply line equipped with a safety grounding system.
 - The power supply line must be protected by suitable magnetothermal and differential switches.
 - A disconnection device must be inserted in the power supply line from the electrical mains (the distance between the contacts must be at least 3.5 mm with an overvoltage category of III) or equivalent system, for example an outlet and relative plug. If the disconnection device for the power supply is not mounted near the automation, it must have a locking system to prevent unintentional, unauthorised connection.

3.2) Fixing the control unit

Insert the two screws in the upper holes provided, sliding them on the guide as in fig. 3a and partly screwing them in. Turn the control unit through 180° and perform the same operation with the other 2 screws. Fix the control unit on to the wall.

Fix the cover on the desired part (with opening on the right or left), press firmly on the arrows.

To remove the cover, press with a screwdriver on the join and push upwards at the same time.

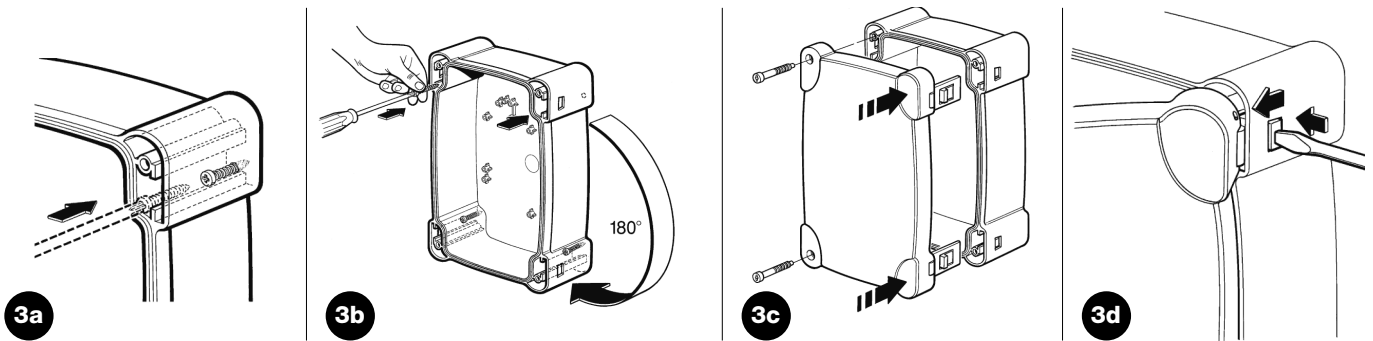

3.3) Diagram of the connections

Once the unit, the actuators, the control (key selector or push button panel) and safety (emergency stop, photoelectric cells, sensitive edges and flashing light) elements have been installed, you can now do the wiring, following the instructions given below.

⚠ To safeguard the operator and avoid damaging the components while you are wiring, whether it is low voltage (230 -120Vac) or extra low voltage (24 V) or if you are plugging in the various cards:

The unit must, under no circumstances, be electrically powered.

We also wish to remind you that if the inputs of the NC (Normally Closed) contacts are not used they should be jumpered; if there is more than one then they should be placed in SERIES with one another; if the inputs of the NO (Normally Open) contacts are not used they should be left free and if there is more than one then they should be placed in PARALLEL with one another. The contacts must be of the mechanical type and free from any potential; no connections are allowed like those defined as “PNP”, “NPN”, “Open Collector” etc., etc.

Carry out the necessary connections, following the diagram in Fig. 4 and the following description of the connections.

⚠ Remember that there are specific standards that must be complied with both as regards the safety of the electrical systems and as regards automatic gates

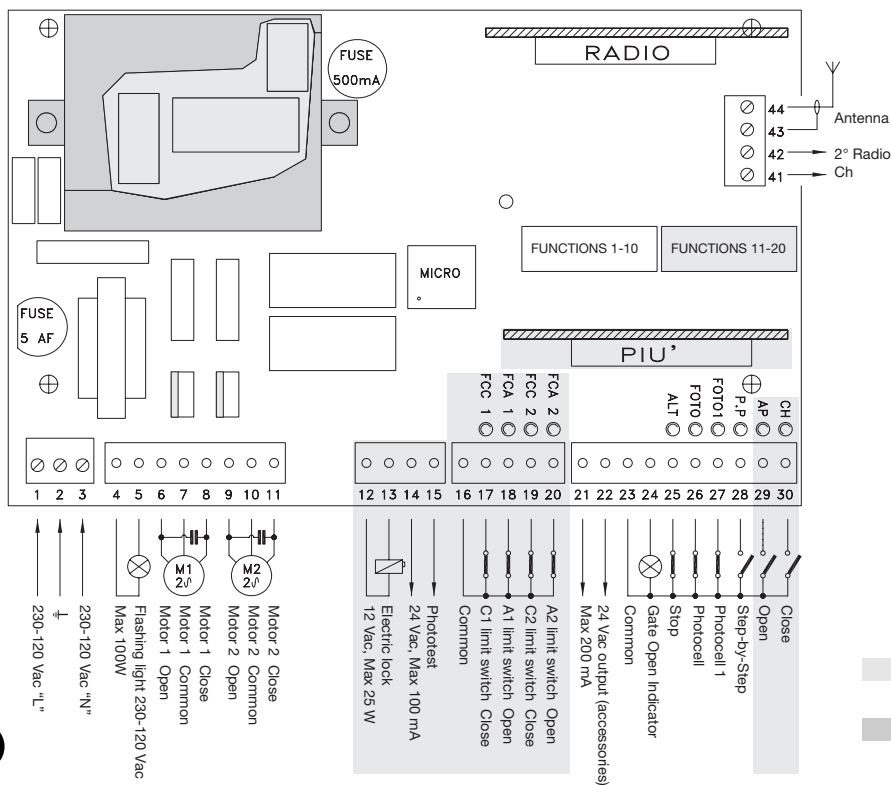

The highlighted part is only found on the **A700F** version.

The highlighted part is found on the **A6F** and **A700F** versions.

4

3.4) Description of the connections

Here is a brief description of the possible connections of the unit to the outside:

- 1...3** : 230 - 120 Vac
- 4-5** : Flashing light = Output for connection to the 230 -120 Vac flashing light, maximum lamp power 100 W
- 6...8** : Motor 1 = Output for connection to the 1st motor 230 - 120 Vac
- 9...11** : Motor 2 = Output for connection to the 2nd motor 230 - 120 Vac

Note: Motors 1 and 2 only differ in the start delay; the 1st motor is connected to the opening delay time "TRA" while the 2nd motor is connected to the closing delay time "TRC". If the delays are unnecessary there is no difference between the motors.

The following terminals are found only on the **A700F** and **A6F** version:

- 12-13** : Electric lock = 12 Vac output to activate the electric lock, 25 W maximum power

You will find the following terminals only on the **A700F** version:

- 14-15** : Phototest = 24 Vac output to feed photoelectric cell transmitters, 100 mA max.
- 16** : Common = Common for limit switch inputs (same as the other common, terminal 23)
- 17** : C1 limit switch = Close limit switch input for motor 1
- 18** : A1 limit switch = Open limit switch input for motor 1
- 19** : C2 limit switch = Close limit switch input for motor 2
- 20** : A2 limit switch = Open limit switch input for motor 2
- 21-22** : 24 Vac = 24 Vac output to feed accessories (Photocell, Radio, etc.) 200 mA max.
- 23** : Common = Common for all inputs (terminal 22 can also be used as Common)
- 24** : Gate Open Indicator = 24 Vac output for gate open indicator, 2 W max. indicator power
- 25** : Stop = Input with STOP function (Emergency, shutdown or extreme safety)
- 26** : Photocell = Input for safety devices (photoelectric cells, pneumatic edges)
- 27** : Photocell 1 = Input for another safety device (photoelectric cells, pneumatic edges)
- 28** : Step-by-Step = Input for cyclic functioning (OPEN STOP CLOSE STOP)

You will find the following terminals only on the **A700F** version:

- 29** : Open = Input for opening (it can be controlled by a timer)
- 30** : Close = Input for closing
- 41-42** : 2° Radio Ch = Output for the second radio receiver channel if there is one
- 43-44** : Antenna = Input for the radio receiver antenna

There are an additional two slots on the unit card for optional cards:

RADIO = Slot for **Nice** radio receivers

PIU' = Slot for **PIU'** expansion card (only on the **A700F** version)

We recommend waiting until installation is complete to plug in the optional cards **RADIO** or **PIU'** and only after having checked that the system is working properly. The optional cards are not necessary for the working of the system and if they are used they make troubleshooting more complex.

3.5) Notes about connections

For the most part, connections are easy; a lot of them are direct connections to a single user point or contact but some are a little more complex:

All the single-phase asynchronous motors need a capacitor for them to work properly; some gearmotors have this capacitor already connected inside while others have to have the capacitor connected externally. In this case, the capacitor must be connected between the motor's OPEN and CLOSE phases. To be more practical the capacitor should be connected directly inside the unit in the spaces left for it.

The following is applicable only to the A700F version

A particular description is given about the "Phototest" output which is nothing else but the best possible solution in terms of reliability as regards safety devices. Each time a manoeuvre is activated the relevant safety devices are checked and only if everything is in order will the manoeuvre start.

Should the test be unsuccessful (the photocell is blinded by the sun, cables have short circuited, etc.) the failure is found and the manoeuvre is not carried out.

All this is possible only by using a certain configuration in the safety devices' connections (Fig. 5).

As you can see from the wiring diagram, while the receivers of the photoelectric cells PHOTOCELL, PHOTOCELL 1 (and PHOTOCELL 2 if it exists - on the PIU' card) are normally supplied by the accessories' 24 V a.c., the transmitters take their power from the phototest output. When movement is requested, first of all it is verified that all the receivers involved in the movement give their consent then the phototest output is turned off after which it is checked that all the receivers signal the fact by removing their consent; lastly, the phototest output is reactivated and consent of all the receivers is verified once again.

As you can see, synchronism has been activated on the two transmitters by cutting the jumpers, this is the only way to guarantee that the two pairs of photoelectric cells do not interfere with one another. Check the instructions in the photocell manual regarding synchronised functioning.

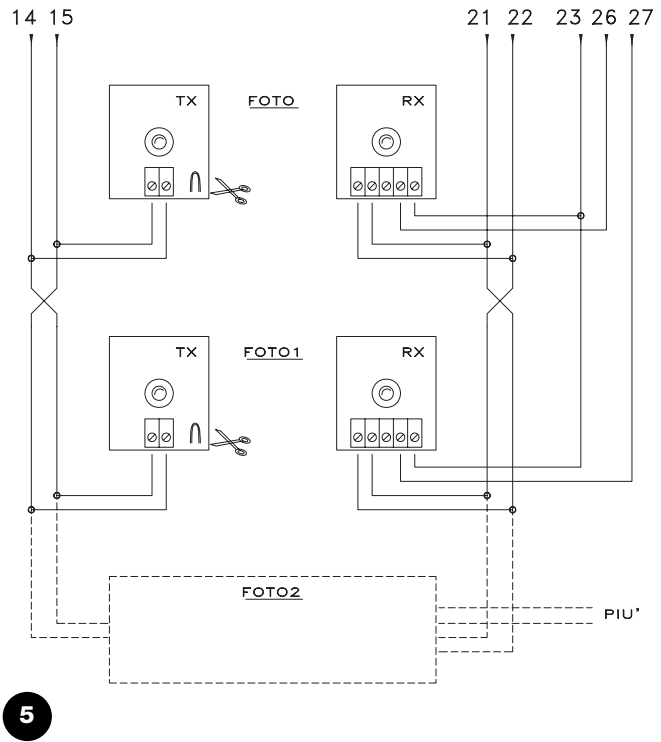

If the "PHOTOCELL" input is not going to be used its terminal must be jumpered via the 24 VAC relay connected on the PHOTOCELL TEST output.

- As a rule gearmotors are used on 2-wing gates that do not need limit switches; it is normal practice to install mechanical stops that stop movement in the point wanted. There is also a "Working Time" trimmer on the control unit that is usually set for a time slightly longer than the time actually needed for the complete manoeuvre. When the gate reaches the mechanical stop the motor stops and remains under stress for the rest of the time; the motors are always designed to withstand this kind of stress without any trouble, especially if the force is set at values lower than 100%.
- In some installations, like for instance in the case of two sliding gates or if you wish to exploit the positioning function, limit switches might be needed. In the majority of cases, if limit switches are used they are the normally closed "NC" type so that if a failure does occur it will cause the motor to stop without the gate getting stuck. In other cases, like for example when magnetic type contacts are used, it is possible that normally open type limit switches have to be used "NO". To enable the control unit to use NO type limit switches you have to cut the FC jumper on the card (Fig. 2). This jumper can also be cut even if limit switches are not used which will avoid having to install the relative jumpers.
- Depending on the type of gearmotor and on the function you wish to achieve, the limit switches can be used as indicators of the end of travel point (limit switch function) or to signal the starting point of the positioning function. If they are used for positioning, they are normally installed at an angle of 10-20° from the stopping point and they indicate the point at which an even weaker force will be applied to the motors, adjustable by means of the POSITIONING FORCE trimmer, so the gate will stop mechanically as gently as possible.

4) Adjustments

- TLM** = Increased Working Time
- TL** = Working Time
- TP** = Pause Time
- TRA** = Opening Delay Time
- TRC** = Closing Delay Time
- F** = Force
- FP** = Positioning Force

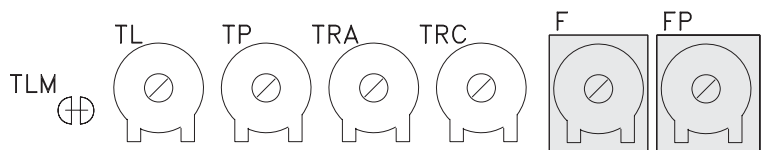

If the gate has 2 wings that could get bump into each other if, when opening, they start simultaneously or, when closing, one moves on top of the other, you will have to readjust the Opening Delay Time trimmer "TRA" or the Closing Delay Time trimmer "TRC". These trimmers can be adjusted to your liking, although as a rule the TRA is set for the time actually needed and the wing moved by the 2nd motor is already out of the way when the 1st motor starts.

The TRC trimmer must be adjusted so that when closing, the wing moved by the 2nd motor always reaches the end only after the 1st motor has terminated the closing manoeuvre.

The Closing Delay Time can be used as a safety margin of 50 cm in closing.

Now select the "Semiautomatic" functioning mode by positioning dip-switch no. 1 in ON and adjust the Working Time trimmer to about halfway of the travel distance. Having made these adjustments, run a complete opening cycle followed by a complete closing cycle and readjust the Working Time trimmer as needed so that there is enough time for the whole manoeuvre leaving a margin of about 2 to 3 seconds. If the trimmer is on maximum and there still is not enough time, the TLM jumper on the printed circuit near the trimmer can be cut to provide more working time.

In some types of actuators, for example the oleodynamic type, force is adjusted directly on the actuator; consult the relative instruction manual regarding adjustment and leave force adjustment inside the unit on maximum.

For all the types of actuators that do not have a force adjustment device it is possible to exploit the adjustment system of the force inside the unit: on the basis of the unit version used, follow the relative instructions.

The following refers only to the A6 version

There is a FORCE trimmer on the unit which is usually set for maximum force; with a screwdriver turn the trimmer counterclockwise to reduce motor force until you reach the value established by the standards.

The following refers only to the A6F e A700F versions

There is an adequately powered autotransformer on the unit with intermediate sockets on the primary winding and which can be selected by means of a special FORCE commutator; turn the commutator round to the most suitable position to reduce motor force until you reach the value established by the standards.

Maximum force is provided whatever system is used to adjust the force for the initial movement phase and for a duration of 1.5 seconds; only after this time, defined "Inrush", is the force established.

If you have chosen the automatic functioning mode (dip-switch No. 2 ON), the end of the opening manoeuvre is followed by a "pause" time at the end of which a closing manoeuvre follows automatically. The time the gate stays open can be adjusted with the PAUSE TIME trimmer for the length of time you want, without any limits. An automatic closing manoeuvre and the relative pause time are activated also in the semiautomatic functioning mode when, in closing, the triggering of a safety device will cause the gate to reverse direction.

Only now, when all the adjustments have been made, do we advise you to plug in the radio receiver if you have one, reminding you that the commands it sends are sent to the STEP-BY-STEP input.

4.1) Functioning modes

Note: some of the parts described below refer only to the **A700F** version.

In the manual functioning mode the OPEN input consents to the opening manoeuvre, the CLOSE input consents to the closing manoeuvre, the STEP-BY-STEP consents to an alternating closing and opening manoeuvre; as soon as the command in input stops, movement stops. If, during an opening manoeuvre, the limit switches trigger or if PHOTOCELL 2 (on the PIU' card) fails to give consent, movement will stop; during a closing manoeuvre, on the other hand, movement will also stop if there is no consent from PHOTOCELL and PHOTOCELL 1. Whether in the opening or closing phase movement, the activation of the STOP command will cause an immediate stopping of movement and a short reverse run.

When a movement is stopped you have to stop the command in input before a new command has the chance to start a new movement. When in one of the automatic functioning modes (semiautomatic, automatic or close always), a command pulse on the OPEN input will cause an opening manoeuvre; if the command persists once fully open, the gate will stay in this position for a "infinite" pause time; only when the command stops can the gate close again.

A pulse on the STEP-BY-STEP causes an alternating closing and opening manoeuvre. A second pulse on the STEP-BY-STEP or on the input that started movement, will cause a Stop.

Both in the opening and closing phases, the activation of the STOP command will cause an immediate stopping of movement and a short reverse run.

If, instead of a pulse on a command input a continuous signal is maintained, a state of "priority" will be created where the other command inputs are disabled (useful if you want to connect a timer or a Night-Day selector). If you have chosen the automatic functioning mode, subsequent to an opening manoeuvre there will be a pause followed by a closing manoeuvre. If, during the pause time, either the PHOTOCELL or PHOTOCELL 1 triggers, the timer will be reset with a new pause time; if, on the other hand, there is a STOP during the pause time, the reclosing function is cancelled and there is a STOP state. Triggering of PHOTOCELL or PHOTOCELL 1 has no effect during an opening manoeuvre but PHOTOCELL 2 (on the PIU' card) will cause reversal of movement; the triggering of PHOTOCELL or PHOTOCELL 1 during a closing manoeuvre will cause reversal of movement followed by a pause time and then a reclosing manoeuvre.

5) Programming

The unit comprises a set of microswitches used to operate various functions so as to render the system more suitable to user needs and safer in the different ways of usage. All functions are activated by placing the dip-switch in the "ON" position while they will not be activated if the corresponding dip-switches are "OFF"; some functions do not have an immediate effect and only have sense in certain conditions like, for instance, the No. 12 function "Flashing also in pause time" which is only active with automatic closing and if the manoeuvre is not interrupted with a STOP command.

⚠ ATTENTION: some of the programmable functions are linked to safety aspects, very carefully evaluate the effects of a function and see which function gives the greatest possible level of safety. When servicing a system, before you modify a programmable function, ascertain the reason why, during installation, certain choices were made and then verify if, with the new programming, safety will be impaired.

5.1) Programmable functions

With the FUNCTIONS dip-switch you can select the various functioning modes and add the functions required according to this table:

Switches 1-2:	Off Off	= "Manual" movement (Man Present)
	On Off	= "Semiautomatic" movement
	Off On	= "Automatic" movement (Automatic Closing)
	On On	= "Automatic+Always Closes" movement
Switch 3	On	= Condominium functioning mode < Not available in the Manual mode>
Switch 4	On	= Preflashing
Switch 5	On	= Recloses immediately after Photocell < Only in the Automatic mode>
Switch 6	On	= Photocell 1 also in Opening
Switch 7	On	= Gradual start
Switch 8	On	= Gradual stop
Switch 9	On	= Water hammering
Switch 10	On	= Courtesy light on flashing

There is a second set of dip-switches with other functions in the **A700F** version:

Switch 11	On	= Positioning function < only with the aid of the limit switch >
Switch 12	On	= Flashing also in Pause < Only in the Automatic mode>
Switch 13	On	= Pressure holding
Switch 14	On	= Gate Open Indicator with proportional flashing
Switch 15	On	= Phototest operation
Switch 16	On	= Photocell and Photocell 1 also in opening
Switch 17	On	= Photocell and Photocell 1 at start of the opening manoeuvre
Switch 18	On	= Misses STOP in opening
Switch 19	On	= Misses STOP in closing
Switch 20	On	= CLOSE becomes PEDESTRIAN OPEN

We wish to remind you that the functions that are possible only in certain cases are indicated with the notes between the symbols "<>" following the description of the function.

Of course, if a dip-switch is "OFF" the function described will not be activated.

5.2) Description of the functions

Here is a brief description of the functions that can be added by switching the relative dip-switch "ON".

Switches 1-2: Off Off = "Manual" movement (Man Present)
On Off = "Semiautomatic" movement
Off On = "Automatic" movement (Automatic Closing)
On On = "Automatic+Always Closes" movement

In the "Manual" functioning mode, the gate will move only as long as the key to command (it is held down).

In the "Semiautomatic" functioning mode a command pulse is enough to carry out the whole movement up to the mechanical stop or until the limit switch triggers. In the "Automatic" functioning mode an opening manoeuvre is followed by a pause and then a closing manoeuvre.

The "Always Closes" function comes into play subsequent to a temporary power cut; if the gate is open a closing manoeuvre starts automatically preceded by 5 seconds of preflashing.

Switch 3: On = Condominium function (not available in the Manual mode)

In the Condominium functioning mode, once an opening manoeuvre has started it cannot be interrupted by other command pulses on STEP-BY-STEP or OPEN until the gate has finished opening. During a closing manoeuvre, a new command pulse will stop the gate and reverse the direction, opening the gate.

Switch 4: On = Preflashing

With a command pulse first of all flashing is activated followed by movement 5 seconds later (2 seconds if on manual).

Switch 5: On = Recloses straight after Photocell (only if in the Automatic mode)

With this function the gate can be kept open only for the length of time needed for transit; in fact, it will close automatically always 5 seconds after the last object has passed by the Photocell or Photocell 1, irrespective of the programmed Pause Time.

Switch 6: On = Photocell 1 also in opening

This is the only function that makes the photoelectric cells PHOTOCELL and PHOTOCELL 1 different. As a rule the safety devices PHOTOCELL and PHOTOCELL 1 will only trigger in the closing manoeuvre, having no effect whatsoever in the opening manoeuvre. If dip-switch No. 6 is turned "ON", the PHOTOCELL will continue triggering only in the closing manoeuvre but PHOTOCELL 1 will trigger also in the opening manoeuvre, causing an interruption in the movement. In the semiautomatic or automatic mode, movement will restart after the last object has passed by PHOTOCELL 1

This is useful to stop the gate in the opening manoeuvre when, for example, a vehicle nears the gate from the inside, which is in the direction of the manoeuvre, without stopping movement when the vehicle nears the gate from the outside.

Switch 7: On = Gradual start

Movement starts gradually, sending an increasing force to the motor forming a ramp that lasts about 1 second, this guarantees a jolt-free start. (Not recommended on METRO gear motor).

Switch 8: On = Gradual stop

When movement finishes, a gradual stop is carried out, sending a diminishing force to the motor with a decrement that lasts about 1 second, this guarantees a jolt-free stop.

For obvious safety reasons, when STOP, PHOTOCELL and PHOTOCELL 1 or PHOTOCELL 2 (on the PIU' card) or one of the limit switches trigger, there is no gradual stop, being replaced by an ordinary stop.

Switch 9: On = Water hammering

When reversible actuators are used, and hence the gate does not remain closed with the mere thrust of the motors, an electric lock has to be installed (see actuator instructions as to use).

Consequently the natural thrust applied to the electric lock might tend to leave the gate wings slightly ajar, sometimes this thrust is so great that it keeps the electric lock's triggering mechanism blocked. With the water hammering function on, a short closing cycle is activated prior to an opening manoeuvre but it causes no movement since the gates are already up against the mechanical closing stop. In this way, when the electric lock is activated, without any force and therefore ready to trigger.

Switch 10: On = Courtesy light on flashing

In certain cases it might be necessary to illuminate the gate movement area and often it is required that the light turn off automatically soon after the gate has finished its manoeuvre. This function is commonly referred to as the "Courtesy light". By connecting appropriate light fixtures to the same output as the flashing light (for a maximum total capacity of 100 W) and activating this function, the output will remain active, illuminating the area for the duration of the manoeuvre plus 60 seconds.

Only on the **A700F** version there is a second set of dip-switches with other functions:

Switch 11: On = Positioning function (only with the use of the limit switches)

The limit switches can be used, instead of for signalling movement limits, for indicating the point in which positioning starts. Normally when the positioning function is used, the limit switches are installed at an angle of 10-20° before the mechanical stop. This means that when the moving wing reaches the limit switch, a reduced force will be sent to the motor which can be adjusted with the "Positioning Force" trimmer for an additional 3 seconds so that the gate can reach the mechanical stop as gently as possible.

Switch 12: On = Flashing also in Pause

The flashing light is normally activated only during the opening and closing manoeuvres, this function means that the flashing light remains active also during the Pause Time to signal the "closing soon" condition.

Switch 13: On = Pressure holding

In the oleodynamic actuators the thrust to keep the gate closed is developed inside a hydraulic circuit which is constantly under pressure. When time and wear reduce the hydraulic circuit's sealing effect it could happen that after a few hours the internal pressure drops and there is the risk of the gate opening slightly.

If the Pressure Holding Function is activated, after 4 hours, and then for each 4 hours that the gate is closed, a brief closing manoeuvre is activated with the sole aim of recharging pressure in the hydraulic circuit.

NOTE: the "Water hammering" and "Pressure Holding" functions only have sense and are carried out if the gate is closed.

The internal logic considers the gate closed if the relative limit switch, FCC, has triggered or, if the limit switches are not used, by the fact that the previous closing manoeuvre was concluded regularly by the end of the working time.

Switch 14: On = Gate Open Indicator with proportional flashing

The Gate Open Indicator normally signals gate condition as follows:

Off: Gate completely closed

On: Gate only partly open

Slow flashing: Gate starting to open

Fast flashing: Gate closing

The flashing of the indicator light during movement can be rendered proportional, going gradually from slow to fast and vice versa; this will provide an indication about the opening and closing state.

Switch 15: On = Phototest activation

This switch starts a test of the photoelectric cells before each movement begins; thus doing, the chance of malfunctioning is eliminated and plant safety is augmented. In order to take advantage of the Phototest function the photoelectric cell transmitters must be connected to the corresponding output (see: Note on connections).

Switch 16: On = Photocell and Photocell 1 also in opening

The safety devices PHOTOCELL and PHOTOCELL 1 normally trigger only in the closing manoeuvre; if dip-switch no. 16 is activated, triggering of the safety devices will cause movement to be interrupted even in the opening phase; if it is set on Semiautomatic or Automatic, movement in the opening direction will start again as soon as the last object has passed by the photoelectric cell.

Switch 17: On = Photocell and Photocell 1 at the beginning of the opening manoeuvre

As a rule the safety devices PHOTOCELL and PHOTOCELL 1 are only active in the closing manoeuvre and not in the opening manoeuvre because the former is the most dangerous. In some countries there are standards that impose the control of the safety devices at least at the beginning also of the opening manoeuvre. If such standards have to be complied with or if you wish to increase the level of safety, it is possible to activate the function and consequently check, prior to starting movement, consent given by the PHOTOCELL and PHOTOCELL 1 safety devices, and only then start movement.

Switch 18: On = Misses STOP in opening

The Step-by-Step cycle is normally: OPEN-STOP-CLOSE-STOP. With this function on, Step-by-Step becomes: OPEN-CLOSE-STOP- OPEN, while the Open input loses its possibility to STOP.

Switch 19: On = Misses STOP in closing

This is similar to the previous function but concerns the closing cycle, hence the Step-by-Step cycle becomes: OPEN-STOP-CLOSE-OPEN, while the Close input loses its possibility to STOP.

NOTE: By turning dip-switches 18 and 19 ON, the step-by-step cycle becomes: OPEN-CLOSE-OPEN, losing its possibility to STOP.

Switch 20: On = CLOSE becomes PEDESTRIAN OPEN

It could happen that you do not need to open the gate fully like, for instance, when a person has to transit; in such a case, the PEDESTRIAN OPEN function is useful which opens just the one gate, connected to the 2nd motor, leaving the other one closed.

This type of opening is activated by the CLOSE input which loses its original function, becoming like the Step-by-Step input, but only for the opening of one gate. We ought to stress that the pedestrian opening cycle will only start if the gate is closed; if the gate is moving or open, the input pulse will have no effect.

ACCESSORY: "PIÙ" EXPANSIONS CARD

The electronic unit is equipped with all the main functions required of a normal automation, in the A700F version there is also the possibility of adding the optional PIU card by means of which unit performance can be enhanced.

The following is only applicable to the **A700F** version

The card must be plugged into the corresponding connector on the unit and consequently the following are available on the card terminals:

- The following inputs:
 - Photocell 2 = Safety device that triggers in the opening manoeuvre
 - Partial Opening = It carries out an opening manoeuvre in a shorter time
 - The following outputs:
 - Red = Red light of the traffic light
 - Green = Green light of the traffic light } Alarms
 - Electric lock = Electric lock command (seeing as the unit is already equipped with this output, the function has been modified to "Suction Pad" to connect the magnetic holding devices that are used as an alternative to the electric lock)
 - Courtesy light = The command of a lamp with the functions of a courtesy light
- Note: The outputs can only command small capacity loads (indicator lamps, relays, etc.)
- and the following adjustments:
 - Partial Time = Time for partial opening
 - Courtesy Time = Time for the courtesy light

The complete features and instructions for using the card are given in the relative instruction manual.

6) Testing

Once the motor and various accessories have been connected you can now check all the connections and test the plant.

A This is the most important stage in the automation system installation procedure in order to ensure maximum safety levels. Testing can also be adopted as a method of periodically checking that all the various devices in the system are functioning correctly.

Testing of the entire system must be performed by qualified and experienced personnel who must establish which tests to conduct on the basis of the risks involved, and verify the compliance of the system with applicable regulations, legislation and standards, in particular with all the provisions of EN standard 12445 which establishes the test methods for automation systems for gates.

We recommend working in the manual mode with all the functions deactivated (dip-switches OFF); in all cases, when you are working in the manual mode and you release the control key the motor will stop immediately. Also check that all the adjustment trimmers are on minimum (turned in the counterclockwise direction), only the FORCE trimmer (on **A6**) or the FORCE commutator (on **A6F** and **A700F**) can be positioned on maximum; the Positioning Force trimmer (on **A700F**) must be positioned halfway.

Each component of the system, e.g. safety edges, photocells, emergency stop, etc. requires a specific testing phase, we therefore recommend observing the procedures shown in the relative instruction manuals.

Ensure that the instructions outlined in this manual and in particular in chapter 1 "WARNINGS" have been observed in full.

- A**) Unlock the gate and take the wings to the halfway point and then lock them, now the gate is free to move in either the opening or closing direction.
- B**) Power the unit and check that voltage between terminals 1-2 and 1-3 is 230 / 120 Vac and 24 V a.c. between terminals 21-22.

The following refers only to the **A700F** version

- C**) Check that voltage on terminals 14-15 is 24 V a.c. for powering the photoelectric cell transmitters.

As soon as the unit is powered the indicator lights (LEDs) on the active inputs should light up; in addition, the "OK" LED should start flashing almost immediately afterwards at regular intervals. If none of this happens, switch power off and check connections more carefully.

- The task of the "OK" LED, in the centre of the card, is to signal the state of the internal logic: regular flashing at 1 second inter-

vals means the internal microprocessor is working and waiting for commands. On the other hand, when the same microprocessor recognises a variation in the state of an input (be it a command input or function dip-switch), a double, quick flashing is generated even if the effects of the variation are not immediate. Extra fast flashing for 3 seconds means that the unit has just been powered and is carrying out a test of the internal parts; lastly an irregular, non constant flashing means that the test was unsuccessful and, consequently, there is a failure.

- D**) Now check that the LEDs of inputs with NC type contacts are on (all the safety devices active) and that the LEDs of inputs with NO type contacts are off (no command present); if this does not happen check connections and effectiveness of the various devices.
- E**) Check that all the safety devices on the plant are working properly (emergency stop, photoelectric cells, pneumatic edges, etc.); each time they trigger the corresponding STOP, PHOTOCCELL or PHOTOCCELL 1 should turn off.
- This is one of the most important checks and must be done with great care, in actual fact the "active" safety of the gate machine depends on the correct functioning of the safety devices. If the flashing light is an excellent instrument for signalling the state of danger and the torque limiting devices are an excellent means to minimise damages, only a correct installation of the safety devices will make it possible to block the automatism before it can cause any damage.

The following refers only to the **A700F** version

- F**) You will have to check correctness of the connections if limit switch inputs are used. Move the wings one at a time and check that once the point wanted is reached, the corresponding limit switch triggers, turning the relative LED off on the unit (or turning it on if NO limit switches are installed).

- Now is the time to check whether movement occurs in the right direction, that is, to see whether movement set on the unit corresponds to that of the gates.

This check is of paramount importance, if the direction is wrong in some cases (in the semiautomatic functioning mode for instance), the gate might appear to be working properly; in fact, the OPEN cycle is similar to the CLOSE cycle but with one basic difference, the safety devices are ignored in the closing manoeuvre which is normally the most dangerous, and they will trigger in the opening manoeuvre causing the gate to reclose up against the obstacle with disastrous results!

G) To see whether or not rotation direction is correct, give a short pulse to the Step-by-Step input; the first manoeuvre the unit will carry out after being powered on is always an OPEN one, so simply verify that the gate starts opening; if movement is wrong you must proceed as follows:

- 1 - Turn power off
- 2 - Reverse the "OPEN" and "CLOSE" connections of the motor or motors that are turning in the wrong direction.

Once this has been done, check if rotation direction is now correct, repeating the procedure described in point "G".

H) Having checked all connections and motor rotation direction, it is possible to try a complete movement of the actuators, we recommend that you always work in the manual mode with all functions deactivated. If you use the Step-by-Step as the command input, the first movement (after turning on) should be an opening one. By means of the command inputs, move the gate until it reaches the open point; if everything goes normally you can then go on to the closing manoeuvre and move the gate until it reaches the stop point.

It is worthwhile carrying out several open and close manoeuvres so you can evaluate any defects in the automation's mechanical structure and also to pinpoint any specific points of friction.

I) Now test triggering of the safety devices; in the opening manoeuvre PHOTOCELL and PHOTOCELL 1 have no effect but in the closing manoeuvre they will stop movement. If the PIU' card is plugged in try functioning of the PHOTOCELL 2 input, in the closing manoeuvre it has no effect while in the opening manoeuvre it will stop movement. The devices connected to the STOP input act both in the opening and closing manoeuvres, stopping movement each time.

L) The hazardous situations caused by the movement of the leaves have been safeguarded by limiting the force of impact, the impact force must be measured according to EN Standard 12445. If the control of the "motor force" is used to assist the system for the reduction of the impact force, try to find the adjustment to obtain optimal results.

6.1) Commissioning

Commissioning can take place only after all the testing phases of the control unit and the other devices have been completed successfully. It is not permissible to execute partial commissioning or to enable use of the system in makeshift conditions.

1. Prepare and store for at least 10 years the technical documentation for the automation, which must include at least the following: assembly drawing of the automation, wiring diagram, analysis of hazards and solutions adopted, manufacturer's declaration of conformity of all the devices installed (for **A6 - A6F - A700F** use the annexed CE declaration of conformity); copy of the instruction manual and maintenance schedule of the automation.

2. Affix a dataplate on the gate providing at least the following data: type of automation, name and address of manufacturer (person responsible for the "commissioning"), serial number, year of manufacture and "CE" marking.

3. Post a permanent label or sign near the gate detailing the operations for the release and manual manoeuvre.

4. Prepare the declaration of conformity of the automation system and deliver it to the owner.

5. Prepare the "Instructions and warnings for the use of the automation system" and deliver it to the owner.

6. Prepare the maintenance schedule of the automation system and deliver it to the owner (this must provide all directions regarding the maintenance of the single automation devices).

7. Before commissioning the automation system inform the owner in writing regarding residual risks and hazards (e.g. in the "Instructions and warnings for the use of the automation system").

7) Maintenance and Disposal

⚠ This charter provides information about how to draw up a maintenance schedule, and the disposal of A6 – A6F –A700F.

7.1) Maintenance

The automation must undergo maintenance work on a regular basis, in order to guarantee prolonged lifetime.

The maintenance operations must be performed in strict compliance with the safety directions provided in this manual and according to the applicable legislation and standards.

If other devices are present, follow the directions provided in the corresponding maintenance schedule different from A6 - A6F - A700F.

1. Is requires scheduled maintenance work every 6 months or 10,000 manoeuvres (max.) after previous maintenance.

2. Disconnect all power supplies.

3. Check for any deterioration of the components which form the automation, paying particular attention to erosion or oxidation of the structural parts. Replace any parts which are below the required standard.

4. Connect the electric power sources up again, and carry out the testing and checks stated in Paragraph "6 Testing".

7.2) Disposal

As in the case of installation, at the end of the product lifetime, disposal procedures must be carried out by qualified personnel.

This product comprises various types of materials, some of which can be recycled while others must be disposed of. Check information on the recycling and disposal procedures according to local legislation for this product category.

⚠ Some parts of the product may contain pollutant or hazardous substances; if disposed of into the environment these may constitute a serious risk of damage to the environment and public health.

As indicated by the symbol in figure never dispose of this product in domestic waste. Apply "classified waste collection" procedures for disposal in accordance with local regulations or return the product to the retailer when purchasing a new model.

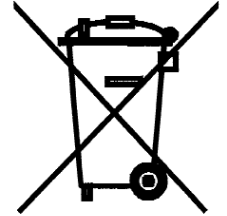

Local regulations may envisage serious fines in the event of illegal disposal of this product.

8) Accessories

The following optional accessories are available for **A6 – A6F – A700F**:

“PIU” CARD:

The unit already has all the functions used in a normal installation but to meet the demands of use in particular installations NICE has designed an optional card “PIU” used to add new functions like traffic light signalling, courtesy light, lock, Photocell2, partial opening of the two gates, and so on.

“RADIO” CARD:

There is a connector in the unit for plugging in a radio card used to act on the STEP-BY-STEP input and thus control the unit remotely by means of a transmitter.

Consult the Nice S.p.a. product catalogue for the complete and updated list of accessories.

9) Technical characteristics

With the aim of improving products, Nice S.p.a reserves the right to modify technical characteristics at any time without notice, while maintaining the same functionalities and intended use.

All technical characteristics stated refer to an ambient temperature of 20°C (±5°C).

Model type:	A6 -A6/V1	A6F -A6F/V1	A700F -A700F/V1
Power A6 – A6F – A700F	230 Vac ± 10%, 50 - 60 Hz		
Power A6/V1 – A6F/V1 - A700F/V1	120 Vac ± 10%, 50 - 60 Hz		
Maximum actuator power 230 Vac	300 W [1,3 A]		
Maximum actuator power /V1 120 Vac	300 W [2,5 A]		
Maximum flashing light power	100W		
Maximum frequency of operating cycles	unlimited		
Maximum time of continuous operation	unlimited		
Maximum current accessories (24 Vac)	200 mA		
Maximum current phototest output	/	/	100 mA
Gate open indicator max. power SCA (24Vac)	2 W		
Maximum electric lock power 12 Vac	/	15 VA	15 VA
Working time	from 2,5 to 40 sec. (from 30 to 80 sec. con TLM)		
Pause time	from 5 to 80 sec.		
TRA opening delay time	0 or from 2.5 to 12 sec.		
TRC closing delay time	0 or from 2.5 to 12 sec.		
Force adjustment	from 0 to 100 %	30%-45%-60%-80%-100%	
Operating temperature	-20 ÷ 50 °C		
Size	280 x 220 x 110 mm		
Weight	1,7 Kg	2,7 Kg	2,7 Kg
Protection level	IP55 (container undamaged)		

Congratulations for having chosen a Nice product for your automation system! Nice S.p.A. produces components for the automation of gates, doors, rolling gates, roller shutters and awnings: gearmotors, control units, radio controls, flashing lights, photocells and miscellaneous accessories. Nice uses only the finest materials and first-class workmanship. It focuses on the development of innovative solutions designed to simplify the use of its equipment, dedicating meticulous care to the study of its technical, aesthetic and ergonomic characteristics: From the wide range of Nice products, your installation technician will certainly have selected the one best suited to your specific requirements. However, Nice is not the producer of your automation system, which is rather the result of a combination of operations carried out by your installation technician, namely analysis, evaluation, selection of materials and system implementation. Each automation system is unique. Your installation technician is the only person who possesses the experience and professionalism needed to set up a system capable of satisfying your requirements, a system that is safe, reliable, long lasting and built in accordance with the regulations in force. An automation system is not only very convenient; it also improves the level of security in your home. Moreover, it will last for years with very little maintenance. Even though the automation system you possess meets the safety requirements of the legislation in force, this does not exclude the existence of a “residual risk”, i.e. the possibility that dangers may arise, usually as a result of improper or unreasonable use. We have prepared the following list of do's and don'ts to help you avoid any mishaps:

- **Before using your automation system for the first time**, ask the installer to explain the origin of residual risks; take a few minutes and read the users **instructions manual given you by the installer**. Retain the manual for future use and deliver it to any subsequent owner of the automation system.
- **Your automation system is a machine that will faithfully execute your commands**; unreasonable or improper use may generate dangers: do not operate the system if there are people, animals or objects within its range of operation.
- **Children**: automation systems are designed to guarantee high levels of safety and security. They are equipped with detection devices that prevent movement if people or objects are in the way, guaranteeing safe and reliable activation. However, children should not be allowed to play in the vicinity of automated systems; to prevent any accidental activations, keep all remote controls away from children: **they are not toys!**
- **Photocells do not constitute actual safety devices, but safety aids**. They are designed using highly reliable technology, but in extreme conditions may be subject to malfunctions or potential faults, and in certain cases these faults are not immediately evident.

For this reason, it is good practice to observe the following:

- Transit is admitted only if the gate or door is completely open with the leaves stationary
- Transit while the gate or door is closing is **STRICTLY PROHIBITED!**

Periodically check correct operation of the photocells and perform the scheduled maintenance at least every six months.

- **Malfunctions**: If you notice that your automation is not functioning properly, disconnect the power supply to the system

and operate the manual release device. Do not attempt to make any repairs; call the installation technician and in the meantime, operate the system like a non-automatic door after releasing the gearmotor as described below.

- **Maintenance**: Like any machine, your automation needs regular periodic maintenance to ensure its long life and total safety. Arrange a periodic maintenance schedule with your installation technician. Nice recommends that maintenance checks be carried out every six months for normal domestic use, but this interval may vary depending on the intensity of use. Only qualified personnel are authorised to carry out checks, maintenance operations and repairs.
- Do not modify the system or its programming and adjustment parameters in any way, even if you feel capable of doing it: your installation technician is responsible for the system.
- The final test, the periodic maintenance operations and any repairs must be documented by the person who has performed them, these documents must remain under the custody of the owner of the system.

The only recommended maintenance operations that the user can perform periodically concern the cleaning of the photocell glasses and the removal of **leaves and debris that may impede the automation**. To prevent anyone from activating the gate release the automation system. Use a slightly damp cloth to clean.

- **Disposal**: At the end of its useful life, the automation must be dismantled by qualified personnel, and the materials must be recycled or disposed of in compliance with the legislation locally in force.
- **In the event of malfunctions or power failures**. While you are waiting for the technician to come or for the power to be restored if your system is not equipped with buffer batteries, you can operate the system like any non-automatic gate. In order to do this you need to manually release the gearmotor (this operation is the only one that the user of the automation is authorized to perform): This operation has been carefully designed by Nice to make it extremely easy, without any need for tools or physical exertion.
- **Replacing the Remote Control Battery**: if your radio control, after a period of time, seems not to work as well, or not to work at all, it may simply be that the battery is exhausted (depending on the type of use, it may last from several months up to one year and more). In this case you will see that the light confirming the transmission is weak, or does not come on, or comes on only briefly. Before calling the installation technician try exchanging the battery with one from another operating transmitter: if the problem is caused by a low battery, just replace it with another of the same type. The batteries contain polluting substances: do not dispose of them together with other waste but use the methods established by local regulations.

Are you satisfied? If you wish to install another automation system in your home, call your old installation technician and use Nice products. You will get the services of a specialist and the most advanced products available on the market, superior performances and maximum system compatibility. Thank you for reading these instructions. We feel confident that you will be well satisfied with your new system: for any present or future requirements, please contact your reliable installation technician.



Nice

Headquarter

Nice SpA

Oderzo TV Italia
Tel. +39.0422.85.38.38
Fax +39.0422.85.35.85
info@niceforyou.com

Nice in Italy

Nice Padova

Sarmeola di Rubano PD Italia
Tel. +39.049.89.78.93.2
Fax +39.049.89.73.85.2
infopd@niceforyou.com

Nice Roma

Roma Italia
Tel. +39.06.72.67.17.61
Fax +39.06.72.67.55.20
inforoma@niceforyou.com

Nice worldwide

Nice France

Buchelay
Tel. +33.(0)1.30.33.95.95
Fax +33.(0)1.30.33.95.96
info@fr.niceforyou.com

Nice Rhône-Alpes

Decines Charpieu France
Tel. +33.(0)4.78.26.56.53
Fax +33.(0)4.78.26.57.53
info@alps.niceforyou.com

Nice France Sud

Aubagne France
Tel. +33.(0)4.42.62.42.52
Fax +33.(0)4.42.62.42.50
infomarseille@fr.niceforyou.com

Nice Belgium

Leuven (Heverlee)
Tel. +32.(0)16.38.69.00
Fax +32.(0)16.38.69.01
info@be.niceforyou.com

Nice España Madrid

Tel. +34.9.16.16.33.00
Fax +34.9.16.16.30.10
info@es.niceforyou.com

Nice España Barcelona

Tel. +34.9.35.88.34.32
Fax +34.9.35.88.42.49
info@es.niceforyou.com

Nice Polska

Pruszków
Tel. +48.22.728.33.22
Fax +48.22.728.25.10
info@pl.niceforyou.com

Nice UK

Chesterfield
Tel. +44.87.07.55.30.10
Fax +44.87.07.55.30.11
info@uk.niceforyou.com

Nice Turkey

Istanbul
info@tr.niceforyou.com

Nice Romania

Cluj Napoca
Tel/Fax +40.264.45.31.27
info@ro.niceforyou.com

Nice Deutschland

Gelnhausen-Hailer
Tel. +49.60.51.91.52-0
Fax +49.60.51.91.52-119
info@de.niceforyou.com

Nice China

Shanghai
Tel. +86.21.575.701.46
+86.21.575.701.45
Fax +86.21.575.701.44
info@cn.niceforyou.com

Nice USA Inc.

Jacksonville, Fl.
Tel. +001.904.786.7133
Fax +001.904.786.7640
info@us.niceforyou.com