

Mindy

Control unit

CE

A60

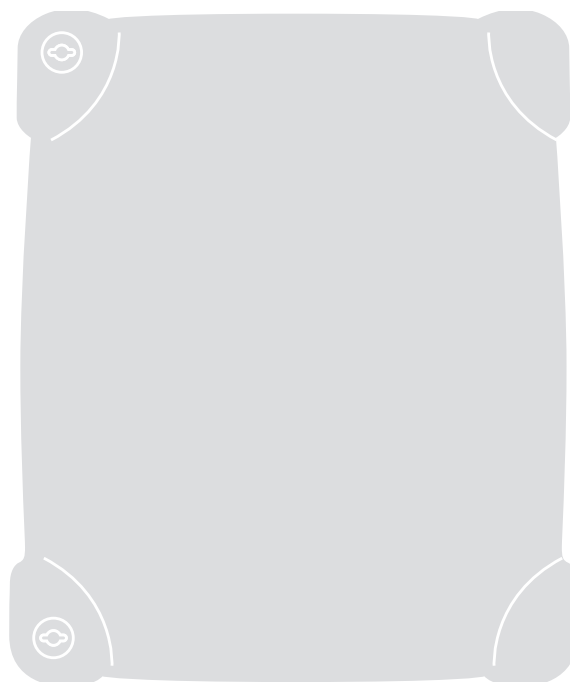

Instructions and warnings for the fitter
Istruzioni ed avvertenze per l'installatore
Instructions et recommandations pour l'installateur
Anweisungen und Hinweise für den Installateur
Instrucciones y advertencias para el instalador
Instrukcje i uwagi dla instalatora
Aanwijzingen en aanbevelingen voor de installateur

Mindy A60

Index:	page				
1	Warnings	3	5	Programming	11
2	Product description	4	5.1	Programmable functions	11
2.1	Operating limits	5	5.2	Description of functions	12
2.2	Typical system	5	6	Testing	13
2.3	List of cables	5	6.1	Commissioning	13
3	Installation	6	7	Maintenance and Disposal	14
3.1	Preliminary checks	6	7.1	Maintenance	14
3.2	Fixing the control unit	6	7.2	Disposal	14
3.3	Electrical connections	7	8	Accessories	14
3.4	Description of electrical connections	7	9	Technical characteristics	14
3.5	Notes about connections	8			
3.6	Checking the connections	9			
4	Adjustments	10			
4.1	Operating modes	11			

1) Warnings

This manual contains important information regarding safety. Before starting installation of the components, it is important that you read all the information contained herein. Store this manual safely for future use.

Due to the dangers which may arise during both the installation and use, installation must be carried out in full observance of the laws, provisions and rules currently in force to ensure maximum safety.

This chapter provides details of general warnings. Other more specific warnings are detailed in Chapters "3.1 Preliminary Checks" and "6 Testing and Commissioning".

⚠ According to the most recent European legislation, the automation of doors or gates is governed by the provisions listed in Directive 98/37/CE (Machine Directive) and, more specifically the standards: EN 13241-1 (harmonised standard); EN 12445; EN 12453 and EN 12635, which enables the declaration of machine conformity to the machine directive.

Visit "www.niceforyou.com" for further information and guidelines for risk analysis and how to draw up the Technical Documentation.

This manual has been especially written for use by qualified fitters. Except for the enclosed specification "Instructions and Warnings for Users" to be removed by the installer, none of the information provided in this manual can be considered as being of interest to the end users!

- Any use or operation not explicitly provided for in these instructions is not permitted. Improper use may cause damage and personal injury.
- A risk analysis must be carried out before starting installation, including a the list of essential safety requisites provided for in Enclosure I of the Machine Directive, indicating the relative solutions employed. N.B. Risk analysis is one of the documents included in the "Technical Documentation" for this automation.
- Check whether additional devices are needed to complete the automation based on the specific application requirements and dangers present. The following risks must be considered: impact, crushing, shearing, dragging, etc. as well as other general dangers.
- Do not modify any components unless such action is specified in this manual. Operations of this type are likely to lead to malfunctions. NICE disclaims any liability for damage resulting from modified products.
- During installation and use, ensure that solid objects or liquids do not penetrate the control unit or other open devices. If necessary, contact the NICE customer service department; use in these conditions can be dangerous.
- The automation system must not be used until it has been commissioned as described in chapter 6 "Testing and commissioning".
- The packaging materials must be disposed of in compliance with local regulations.
- If a fault occurs that cannot be solved using the information provided in this manual, contact the NICE customer service department.
- In the event that any automatic switches are tripped or fuses blown, attempt to identify and eliminate the relative fault.
- Disconnect all the power supply circuits before accessing the terminals inside the cover. If the disconnection device is not identifiable, affix the following sign: "WARNING: MAINTENANCE WORK IN PROGRESS".

Special warnings concerning the suitable use of this product in relation to the 98/37CE "Machine Directive" (ex 89/392/CEE):

- This product is issued on the market as a "machine component" and is therefore manufactured to be integrated in a machine or assembled with other machines in order to create "a machine", in accordance with the directive 98/37/EC, exclusively in combination with other components and in the manner described in the present instructions manual. As specified in the directive 98/37CE the use of this product is not admitted until the manufacturer of the machine on which this product is mounted has identified and declared it as conforming to the directive 98/37/CE.

Special warnings concerning suitable use of this product in relation to the 73/23/EEC "Low Voltage" Directive and subsequent amendments 93/68/CEE

- This product complies with the provisions envisaged by the "Low Voltage" Directive if used in the configurations foreseen in this instruction manual and in combination with the articles present in the Nice S.p.a. product catalogue. If the product is not used in the specified configurations or is used with other products that have not been foreseen, the requirements may not be guaranteed; use of the product is prohibited in these conditions until compliance with the requirements foreseen by the directive has been verified by installers.

Special warnings concerning suitable use of this product in relation to the 89/336/EEC "Electromagnetic Compatibility" Directive and subsequent amendments 92/31/EEC and 93/68/EEC:

- This product has undergone tests regarding electromagnetic compatibility in the most critical of use conditions, in the configurations foreseen in this instruction manual and in combination with articles present in the Nice S.p.A. product catalogue. Electromagnetic compatibility may not be guaranteed if used in configurations or with other products that have not been foreseen; use of the product is prohibited in these conditions until compliance with the requirements foreseen by the directive has been verified by installers.

2) Product description

This control unit for the automation of gates and doors enables control of two gearmotors with single-phase alternating current.

The unit features a series of Dip-switches (mini switches) that enable the selection of the various functions, as well as trimmers used for making adjustments.

The status of the inputs is signalled by LED's located next to the inputs. An additional LED located near the microprocessor indicates whether the internal logic is operating properly.

To facilitate part identification, **Fig.1** below shows the most significant components.

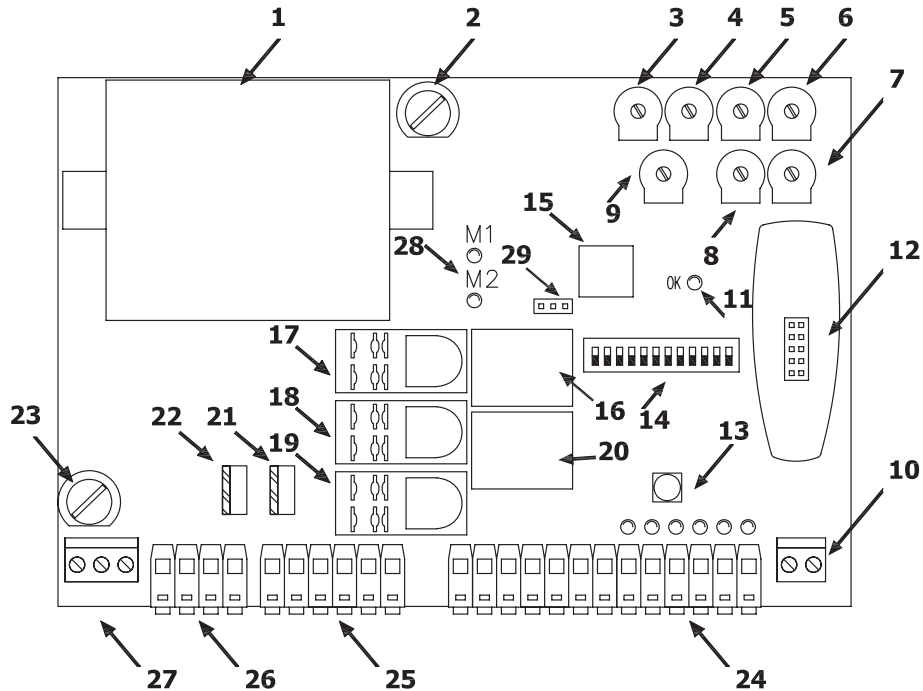

1

- | | |
|--|---|
| 1 Transformer | 16 Electric lock relay |
| 2 Low voltage fuse (500 mA F) | 17 Common motor relay |
| 3 Force adjustment trimmer (F) | 18 Courtesy light relay |
| 4 Pause Time adjustment trimmer (TP) | 19 Open / Close movement direction relay |
| 5 Opening Time Delay adjustment trimmer (TRA) | 20 Phototest relay |
| 6 Motor 1 Working Time adjustment trimmer (TL1) | 21 Motor 2 Triac |
| 7 Motor 2 Working Time adjustment trimmer (TL2) | 22 Motor 1 Triac |
| 8 Closing Time Delay adjustment trimmer (TRC) | 23 Rapid fuse (5A 230Vac) or (6.3A 120Vac) power |
| 9 Manoeuvre balance trimmer (BAL) | 24 Input / output control terminal board |
| 10 Terminal board for aerial | 25 Motor outputs terminal board |
| 11 Led OK | 26 Flashing / C.tsy light output terminal board |
| 12 Radio slot connector | 27 Power supply terminal board |
| 13 Step-by-step button | 28 Motors ON LED |
| 14 Function selection Dip-Switch | 29 Jumper for selection of deceleration mode (M-RAL) |
| 15 Microprocessor | |

2.1) Operating limits

Chapter 9 "Technical Characteristics" provides the only data needed to determine whether the products are suitable for the intended application.

2.2) Typical system

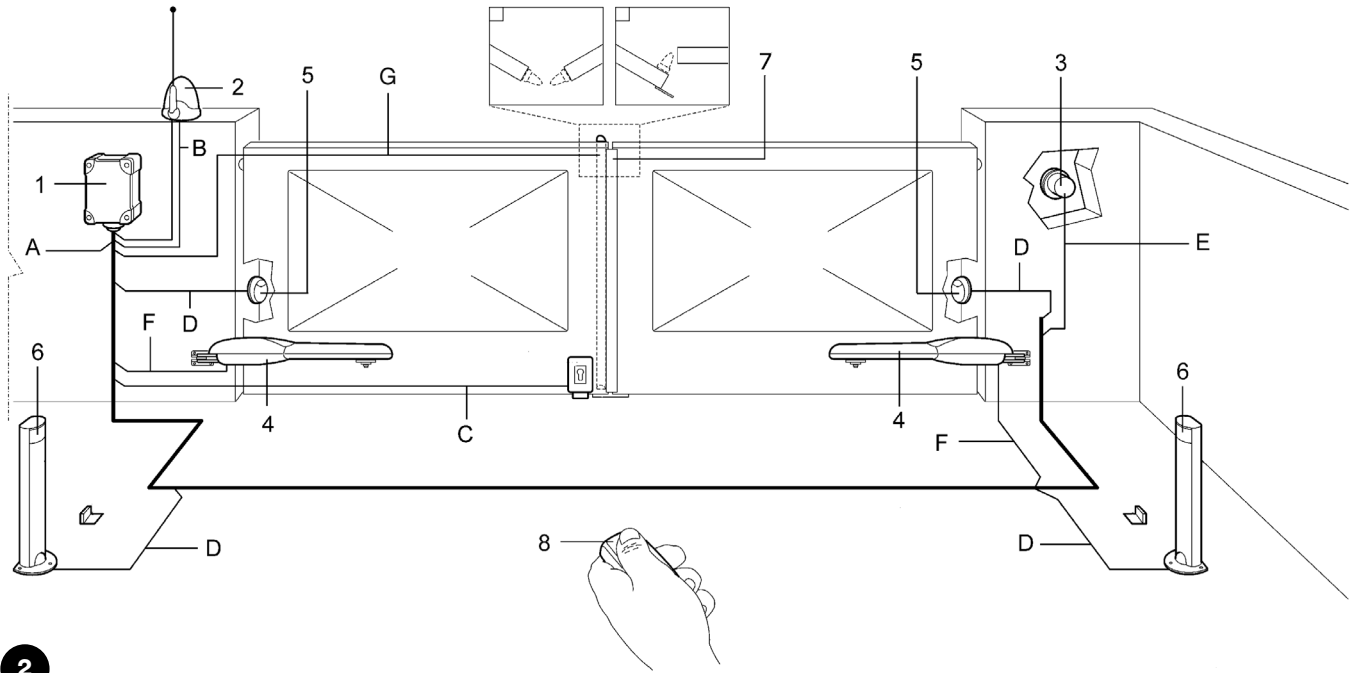

2

- 1. Control Unit A60
- 2. Flashing light with incorporated aerial
- 3. Key-operated selector switch
- 4. Motors
- 5. Couple of photoelectric cells PHOTO
- 6. Couple of photoelectric cells PHOTO 1
- 7. Sensitive edge
- 8. Radio transmitter

2.3) List of cables

The typical system shown in figure 2 also states the cables required for connection of the various devices, the specifications of which are provided in table 1.

⚠ The cables used must be suitable for the type of installation; for example, an H03VV-F type cable is recommended for indoor applications, while H07RN-F is suitable for outdoor applications.

Table 1: List of cables

Connection	Tipo cavo	Maximum admissible length
A: Electrical power line	N°1 cable 3x1,5mm ²	30m (note 1)
B: Flashing light with aerial	N°1 cable 2x0,5mm ²	20m
	N°1 shielded cable type RG58	20m (less than 5m recommended)
C: Electric lock	N°1 cable 2x1mm ²	20m
D: Photocells	N°1 cable 2x0,25mm ² (Tx)	30m
	N°1 cable 4x0,25mm ² (Rx)	30m
E: Key-operated selector switch	N°1 cable 4x0,25mm ²	30m
F: Connection to the motors.	N°1 cable 4x1,5mm ²	3m
G: Connection to sensitive edge	N°1 cable 2x0,25mm ²	30m

Note 1: power supply cable longer than 30m may be used provided it has a larger gauge, e.g. 3x2,5mm², and that a safety earthing system is provided near the automation unit.

3) Installation

⚠ The installation must be carried out by qualified personnel in compliance with current legislation, standards and regulations, and the directions provided in this manual.

3.1) Preliminary checks

Before proceeding with the installation:

- Check that all the materials are in excellent condition, suitable for use and compliant with current standards.
 - Ensure that the structure of the gate is suitable for automation.
 - Ensure that the mounting positions of the various devices are protected from impact and that the mounting surfaces are sufficiently sturdy.
 - Install cable or pipe leads only at the bottom of the unit; for no reason whatsoever must the side and top walls be perforated. The cables must only enter the unit from the bottom!
 - Insert suitable mechanical stops, anchored to the ground, both for opening and closing manoeuvres.
 - Components must never be immersed in water or other liquids. Keep away from heat sources and open flames; in acid, saline or potentially explosive atmosphere; this could damage A60 and cause malfunctions or hazardous situations.
 - If there is an access door in the leaf, or within the range of movement of the gate, make sure that it does not obstruct normal travel. Mount a suitable interlock system if necessary.
 - Only connect the control unit to a power supply line equipped with a safety grounding system.
- The power supply line must be protected by suitable magnetothermal and differential switches.
 - A disconnection device must be inserted in the power supply line from the electrical mains (the distance between the contacts must be at least 3.5mm with an overvoltage category of III) or equivalent system, for example an outlet and relative plug. If the disconnection device for the power supply is not mounted near the automation, it must have a locking system to prevent unintentional, unauthorised connection.

3.2) Fixing the control unit

Insert the two screws in the upper holes provided, sliding them on the guide as in fig. 3a and partly screwing them in. Turn the control unit through 180° and perform the same operation with the other 2 screws. Fix the control unit on to the wall.

Fix the cover on the desired part (with opening on the right or left), press firmly on the arrows.

To remove the cover, press with a screwdriver on the join and push upwards at the same time.

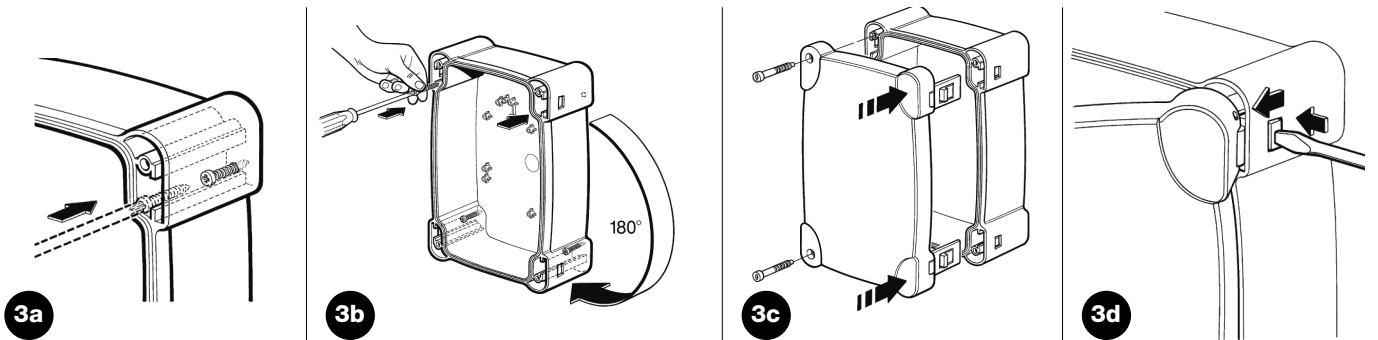

3.3) Electrical connections

⚠ To safeguard the operator and avoid damaging the components, make sure that the control unit is switched off while you are wiring or plugging in the various cards.

- Power the control unit using a 3 x 1.5 mm² cable; should the distance between the unit and the earth connection exceed 30m, install an earth plate near the unit.
- Use wires with a minimum cross-section of 0.25 mm² to connect extra-low voltage safety circuits.
- Use shielded wires if the length exceeds 30m and only connect the earth braid to the control unit side.
- Do not make connections to cables in buried boxes even if they are completely watertight.
- If the inputs of the Normally Closed (NC) contacts are not used, they should be jumped with the “24V common” terminal except for the photocell inputs if the phototest function is enabled. For further information please see the paragraph 3.5 “Notes about connections” in the part “ Phototest “.
- If there is more than one (NC) contact on the same input, they must be connected in SERIES.
- If the inputs of the Normally Open (NA) contacts are not used they should be left free.
- If there is more than one (NA) contact on the same input, they must be connected in PARALLEL.
- The contacts must be mechanical and potential-free; no stage connections are allowed, such as those defined as "PNP", "NPN", "Open Collector", etc.

Carry out the necessary connections, following the diagram in **Fig. 4** and the following description of the connections. Remember that there are specific standards that must be complied with both as regards the safety of the electrical systems and as regards automatic gates.

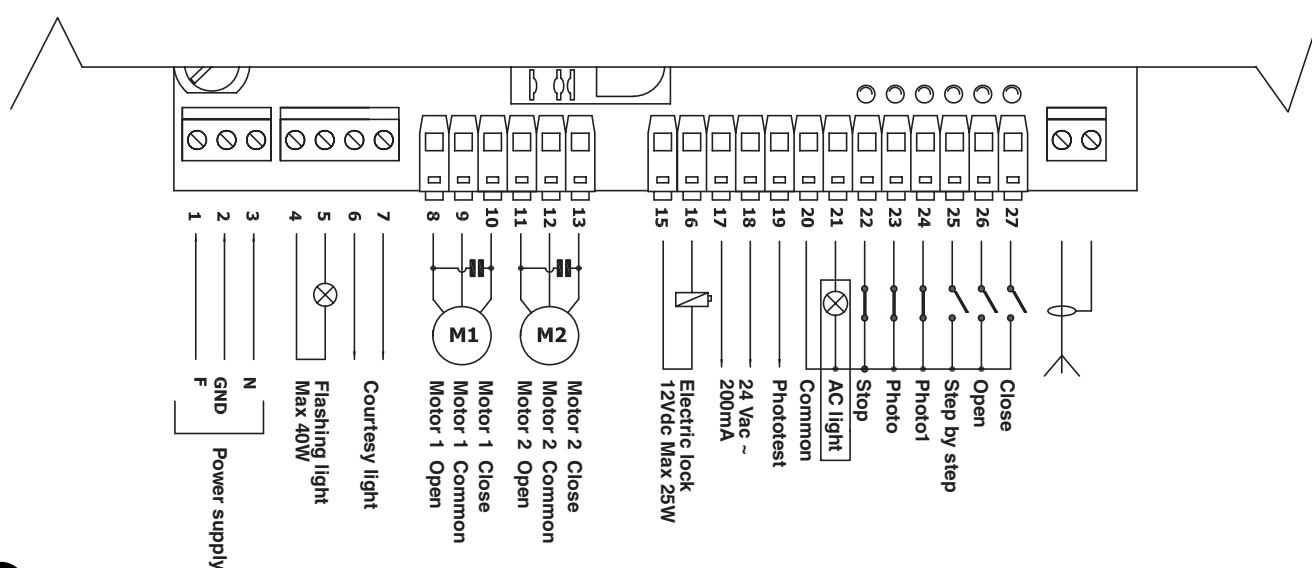

4

3.4) Description of electrical connections

The following table provides a brief description of the possible control unit output connections.

Terminals	Function	Description
1-2-3 :	Power supply =	Mains power line
4-5 :	Flashing light =	Output for connecting flashing light to mains voltage (Max. 40W)
6-7 :	Courtesy light =	Clean contact output for courtesy light connection (Max. 5A)
8-9-10 :	Motor1 =	Motor 1 control output,
11-12-13 :	Motor2 =	Motor 2 control output
15-16 :	Electric lock =	12 Vdc output for electric lock activation, max. power 25W
17-18 :	24 Vac =	Power supply to 24Vac services (Max. 200 mA)
19 :	Phototest =	Phototest output - “TX” power supply to photocells - (Max. 75 mA)
20 :	Common =	Common for all inputs
21 :	AC light =	24 Vac output for open gate indicator light (Max. 2W)
22 :	Stop =	Input with “Stop” function (Stop and short reverse run)
23 :	Photo =	Input for safety devices
24 :	Photo1 =	Input for additional safety device
25 :	Step by step (PP) =	Input for cyclic movement (“Open” – “Stop” – “Close” – “Stop”)
26 :	Open =	Input for opening function
27 :	Close =	Input for closing function
	Aerial =	Input for the radio receiver aerial

3.5) Notes about connections

For the most part, connections are easy; a lot of them are direct connections to a single user point or contact but some are a little more complex:

All the single-phase asynchronous motors need a capacitor for them to work properly; some gearmotors have this capacitor already connected inside while others have to have the capacitor connected externally. In this case, the capacitor must be connected between the motor's OPEN and CLOSE phases. To be more practical the capacitor should be connected directly inside the unit.

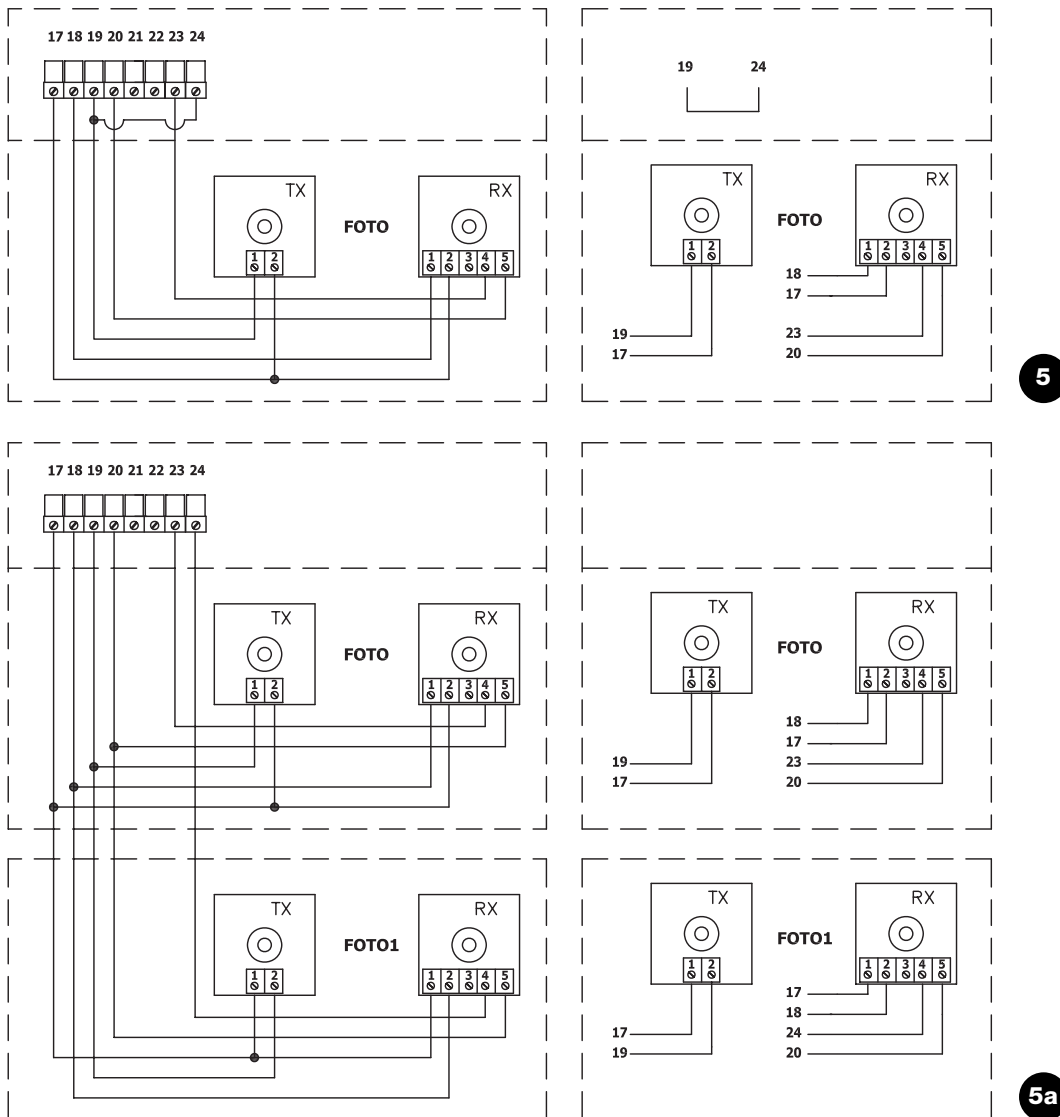

The "Phototest" function improves the reliability of the safety devices and puts the control unit and safety photocells in "category 2" according to EN 954-1 standard (ed. 12/1996).

Each time a manoeuvre is begun, the related safety devices are checked and the manoeuvre is started only if everything is in order. Should the test be unsuccessful (the photocell is blinded by the sun, cables have short circuited, etc.) the failure is identified and the manoeuvre is not carried out.

To enable the Phototest function:

- Set Dip Switch 10 to ON
- Connect the safety devices as shown in **fig. 5** (when using the PHOTO output alone), or as shown in **fig. 5a** (when using PHOTO1 as well).

The photocell transmitters are not powered directly from the service output, but through the dedicated PHOTOTEST output. The maximum current available at the PHOTOTEST output is 75mA (3 pairs of photocells).

- Power the receivers directly from the service output of the control unit (terminals 17-18).

The photocells are tested as follows: when a movement is required, all the receivers involved in the movement are checked to make sure they give their consent, then power to the transmitters is disconnected; next all the receivers are checked to make sure they signal the fact by withholding their consent; the transmitters are then powered and the consent of all the receivers is verified once more. Only if this sequence is successfully carried out will the manoeuvre be performed.

It is always a good idea to activate the synchronisation function by cutting the jumpers on the transmitters. This is the only way to make sure that two pairs of photocells will not interfere with each other. Read the instructions for "SYNCHRONISED" operation in the photocell manual.

If an input subjected to PHOTOTEST is not being used (see PHOTO1) but you still require the phototest function, connect the unused input with the PHOTOTEST output (terminals 19-24) using a jumper; see **fig. 5a**.

If at a later time the Phototest function is no longer required, set Dip-Switch 10 to the OFF position.

3.6) Checking the connections

⚠ The following operations entail working on live circuits; most of these run on extra-low safety voltage so they are not dangerous; however, some are mains voltage circuits, which means they are HIGHLY DANGEROUS! Pay the utmost attention to what you are doing and NEVER WORK ALONE!

- Power the control unit and check that voltage between terminals 17-18 is approx. 24Vac.
- Check that the “OK” LED flashes rapidly for a few moments and then that it flashes at a regular frequency.
- Now check that the LED’s related to the N.C. (Normally Closed) contacts are on (all safety devices active) and that the LED’s related to the N.O. (Normally Open) inputs are off (no command); if this is not the case, check the connections and efficiency of the various devices. The STOP input switches off both FCA and FCC.
- Release the leaves, take them to the halfway point and then stop them; this way the leaves will be free to move in either the opening or closing direction.
- Now make sure that movement occurs in the right direction, i.e., see whether the movement set on the unit corresponds to that of the leaves. This check is of paramount importance, if the direction is wrong, in some cases (in the “Semiautomatic” mode, for instance) the “Automatic” system might appear to be working properly; in fact, the OPEN cycle is similar to the CLOSE cycle but with one basic difference: the safety devices are ignored in the closing manoeuvre, which is normally the most dangerous, and they will trigger in the opening manoeuvre, causing the gate to close against an obstacle with disastrous results!
- To see whether the direction of rotation is correct, give a short impulse to the Open input and make sure that the automatic system moves in the opening direction; if this movement is incorrect, proceed as follows:
 - Turn the power off
 - Invert the power conductors of the wrong motor/s. (In the case of M1, invert the connection of terminals 8-10; for M2, invert the connection of terminals 11 – 13).
 - Once this has been done, check whether the direction of rotation is correct by repeating the last operation.

The “OK” LED located in the centre of the board next to the microprocessor has the task of signalling the status of the internal logic: regular flashing at 1 second intervals indicates that the internal microprocessor is active and waiting for commands. When the microprocessor recognises a variation in the status of an input (whether it is a command or a function Dip-Switch input) it generates a rapid double flash even if the variation does not have any immediate effects. Extremely rapid flashing for 3 seconds means that the control unit has just been powered or is carrying out internal testing. Lastly, irregular flashing means that the test has been unsuccessful and that a fault has occurred.

4) Adjustments

Adjustments can be made through trimmers that modify the following parameters:

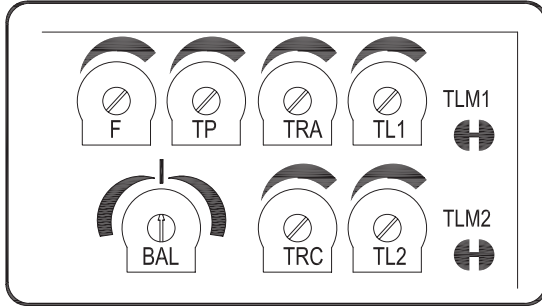

• WORKING TIME (TL1 TL2):

These adjust the maximum duration of the opening or closing manoeuvre of motor 1 (TL1) and motor 2 (TL2).

The adjustments made to the trimmers (TL1 TL2) take effect the first time a closed gate performs an opening manoeuvre (working time of the 2 leaves finished). Therefore always adjust the trimmers when the gate is closed.

If gearmotors with electric limit switches or limit stops are used, adjust these switches or stops to maximise the opening or closing range of a leaf.

To adjust the working times TL, select the “Semiautomatic” operating mode by setting Dip-Switch 1 to ON, then adjust the TL trimmers to halfway along the travel distance. When these adjustments have been made, execute an opening and closing cycle; if necessary also adjust the TL trimmers so that there is enough time to execute the entire manoeuvre and still leave a margin of 2 or 3 seconds before the electric limit switches (on the motors with limit switches) or the limit stops cut-in.

In order to check when the working time for the two motors terminates, check whether the Motors ON LEDs, located on the control unit, have switched off. (The LEDs will switch off when the Working Time for the respective motor is up).

If the TL trimmers are at maximum and there still is not enough time to perform the entire manoeuvre, cut the TLM1 jumper to increase the working time of motor 1 and cut the TLM2 jumper to increase the working time of motor 2. These jumpers are located alongside the corresponding trimmers.

If you wish to use the DECELERATION function (Dip-Switch 8 On), adjust the working time trimmers so that the motors begin the deceleration stage approximately 50 - 70cm before the opening or closing limit stops are reached.

• OPENING TIME DELAY (TRA) AND CLOSING TIME DELAY (TRC):

If the gate has two leaves that might jam if they start moving simultaneously, or that might overlap when closing, you need to adjust the Opening Time Delay trimmer (TRA) or the Closing Time Delay (TRC) trimmer to overcome these problems.

The TRA trimmer must be adjusted to ensure that the leaf moved by the second motor is out of the range of the leaf moved by the first motor when the latter starts moving.

The TRC trimmer must be adjusted to ensure that, during the closing operation, the leaf moved by the second motor reaches the end of its travel after the first motor has completed its closing manoeuvre.

• PAUSE TIME (TP):

In “Automatic” mode, this adjusts the time span between the end of the opening manoeuvre and the beginning of the closing manoeuvre.

• FORCE (F):

Take great care when adjusting the FORCE (F) trimmer, as this may affect the level of safety of the automatic system. Trial by error is required to adjust this parameter, measuring the force applied to the leaf and comparing it with regulatory values.

• BALANCING manoeuvre times (BAL):

The BALANCE trimmer on this control unit enables a differentiation between the work time between leaf opening and closing manoeuvres.

This is useful when the motor has different speeds in the two directions, such as in the case of hydraulic motors or when the gate leaves are offset in opening and closing, causing different force levels and thus requiring different travel times within the same space.

Therefore if the gate is offset in closing, the opening manoeuvre may terminate before reaching the mechanical stops, in which case rotate the BAL trimmer clockwise (Op) to increase the opening time until the deceleration starts at the set point (50 cm before the mechanical stop) and the manoeuvre lasts for a further 3-5 seconds after the leaves have reached the mechanical stops.

On the other hand, if the gate is offset in opening, balance by rotating the BAL trimmer anti-clockwise (Cl) to extend the closing manoeuvre time.

If the trimmer is positioned exactly at the centre, the opening and closing manoeuvres will have the same work time.

4.1) Operating modes

In the manual operating mode, the OPEN input enables an opening movement, while the CLOSE input enables a closing movement. The STEP-BY-STEP input enables an alternating opening and closing movement. Movement stops as soon as the input command stops. During an opening or closing manoeuvre, movement will stop also when the command input or the signal from the safety devices is disabled. During both opening and closing manoeuvres, the activation of the STOP command will cause the movement to stop immediately. When a movement is stopped, stop the input command before giving a command to start a new movement.

When one of the automatic modes (“Semiautomatic”, “Automatic” or “Automatic + Close Always”) is operational, a command impulse to the OPEN input causes an opening manoeuvre. A command impulse to the STEP-BY-STEP input begins an alternating closing and opening manoeuvre. A second impulse to the STEP-BY-STEP input or to the same input the started the movement will cause it to stop.

Both in the opening and closing phases, the activation of the STOP command will cause an immediate stopping of movement and a short reverse run. If a continuous signal rather than an impulse is maintained in a command input, a “prevalence” condition will be generated causing the other command inputs to be disabled (**this is useful if you need to connect a clock or a Night/Day selector switch**).

If an automatic operating mode has been chosen, the opening manoeuvre will be followed by a pause and then a closing manoeuvre. If PHOTO triggers during the pause, the timer will be reset with a new pause time; if, on the other hand, STOP is activated during the pause, the closing function will be cancelled and the system will switch to the STOP mode.

PHOTO will have no effect if it is triggered during the opening manoeuvre, however if PHOTO is triggered during the closing manoeuvre, the movement will reverse, pause, and then start to close again.

5) Programming

The unit comprises a set of microswitches used to operate various functions so as to render the system more suitable to user needs and safer in the different ways of usage. All functions are activated by placing the dip-switch in the “ON” position while they will not be activated if the corresponding dip-switches are “OFF”; some functions do not have an immediate effect and only have sense in certain conditions like.

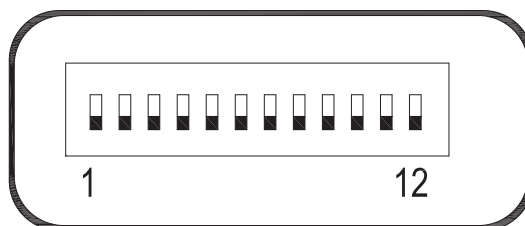

⚠ ATTENTION: some of the programmable functions are linked to safety aspects, very carefully evaluate the effects of a function and see which function gives the greatest possible level of safety.

When servicing a system, before you modify a programmable function, ascertain the reason why, during installation, certain choices were made and then verify if, with the new programming, safety will be impaired.

5.1) Programmable functions

With the FUNCTIONS dip-switch you can select the various functioning modes and add the functions required according to this table:

Switch 1-2	Off Off	= “Manual” movement, i.e. hand operated
	On-Off	= “Semiautomatic” movement
	Off-On	= “Automatic” movement, i.e. automatic closing
	On-On	= “Automatic + always close” movement
Switch 3	On	= Condominium operation < not available in manual mode >
Switch 4	On	= Pre-flashing
Switch 5	On	= Close 5” after Photo < in automatic mode > or Close after Photo < in semiautomatic mode >
Switch 6	On	= “Photo1” safety also during opening manoeuvres
Switch 7	On	= Ramming
Switch 8	On	= Deceleration
Switch 9	On	= Maintain pressure
Switch 10	On	= Phototest
Switch 11	On	= Courtesy Light in impulse mode
Switch 12	On	= Close becomes Open for Pedestrians

Note 1: Some functions are only available in certain conditions; these are explained by the notes between the characters “<...>”.

5.2) Description of functions

Here is a brief description of the functions that can be added by setting the corresponding Dip-Switch to "ON".

Switch 1-2: Off Off = "Manual" movement (hand operated)
On-Off = "Semiautomatic" movement
Off-On = "Automatic" movement (automatic closing)
On-On = "Automatic + Always Close" movement

In the "Manual" operating mode, the gate will only move as long as the control button is held down.

In "Semiautomatic" mode, a command impulse will perform the whole movement until the Working Time limit expires or the limit stop is reached. In the "Automatic" operating mode, an opening manoeuvre is followed by a pause, after which the gate closes automatically. The "Always Close" function comes into play following a power failure, automatically activating a closing manoeuvre preceded by 5 seconds of pre-flashing.

Switch 3: On = Condominium operation (not available in Manual mode)

In the Condominium operating mode, once an opening manoeuvre has started it cannot be interrupted by other command impulses, such as STEP-BY-STEP or OPEN, until the gate has finished opening. During a closing manoeuvre, a new command impulse will stop the gate and reverse the direction of movement in order to open the gate.

Switch 4: On = Pre-flashing

A command impulse activates the flashing light, followed by movement 5 seconds later (2 seconds later in manual mode).

Switch 5: On = Close 5" after Photo < in automatic mode > or Close after Photo < in semiautomatic mode >

This function, in Automatic mode, allows the gate to be kept open only for the time required for transit; when the PHOTO stage is over, the manoeuvre stops. After 5 seconds a closing manoeuvre will automatically begin. If PHOTO triggers in the "Semiautomatic" mode during a closing manoeuvre, the "Automatic" closing manoeuvre is activated with a set pause time.

Switch 6: On = Safety (Photo1) also during the opening manoeuvre
The "Photo1" safety device is normally active only during the closing manoeuvre; if Dip-Switch 6 is turned "On", the safety device will cause the movement to stop also during the opening manoeuvre.

In the Semiautomatic or Automatic modes, the opening manoeuvre will start again immediately after the photocell has been disengaged.

Switch 7: On = Ramming

When reversible actuators are used, so that the gate does not remain closed thanks to the thrust of the motors alone, it is necessary to install an electric lock (see actuators' operating instructions). The electric lock may apply a natural thrust to the gate, causing the leaves to open slightly; at times this thrust is so powerful as to cause the locking mechanism to jam.

With the ramming function on, a brief closing cycle is activated before an opening manoeuvre is started. This, however, will not generate any actual movement since the leaves will already be positioned against the closing limit stop.

This way, when the electric lock is activated it will be free from the effects of unwanted forces and will readily click open.

Switch 8: On = Deceleration

Deceleration consists in a 30% reduction of the nominal speed, to reduce the impact force in the gate opening and closing zones.

The deceleration function slows down the automation speed and reduces motor torque by 70%.

In automations requiring a high torque, this torque reduction could

cause shutdown of the motors.

For this reason, this function is disabled on heavyweight gates and those subject to high friction.

Once the deceleration function is enabled, the Work Time (WT) trimmer must be adjusted as the deceleration start depends on the set Work Time. Therefore set the Work Time so that deceleration starts at approx. 50 cm before the mechanical stops to ensure that the manoeuvre lasts a further 3-5 seconds after reaching the mechanical stop.

A jumper (M-RAL) is fitted on the control unit to enable selection of the two DECELERATION modes; one with 70% torque reduction and one with 60% torque reduction to use on heavier gates.

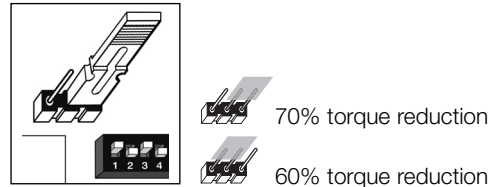

Note that during deceleration, the motor noise levels increase slightly. Before adjusting deceleration settings, read paragraph "4 Adjustments" with special reference to the operation of the Balance trimmer (BAL).

Switch 9: On = Maintain pressure

With hydraulic actuators, the thrust required to keep the gate closed is generated by a hydraulic circuit which is constantly under pressure.

However, time and wear tend to reduce the seal of the hydraulic circuit. Consequently, after a few hours of operation the internal pressure may drop, causing the leaves to open slightly.

If the "Maintain Pressure" function is enabled, every 4 hours that the gate remains closed a brief closing manoeuvre is activated in order to restore the hydraulic circuit pressure.

Switch 10: On = Phototest

This function checks photocell efficiency at the beginning of each manoeuvre. See the PHOTOTEST chapter.

Switch 11: On = Courtesy light in impulse mode

In this mode, the clean contact of the courtesy light output will remain closed for 1 sec. at the starting of each opening or closing manoeuvre, thus enabling a command impulse to be sent to an external timer.

Switch 12: On = CLOSE becomes OPEN for Pedestrians

In this mode, the CLOSE input loses its basic function and becomes a Pedestrian Step-by-Step input that allows the gate leaf controlled by motor 2 to be opened for pedestrian access.

The Pedestrian opening cycle can only be activated when the gate is closed, while if the gate is moving or open the impulse has no effect on the input.

6) Testing

After the above checks and adjustments have been made, the system can be tested.

⚠ The automation system must be tested by qualified and experienced personnel who must establish what tests to perform based on the risks involved.

Testing is the most important part of the whole automation process. Each single component, e.g. motor, emergency stop, photocells, etc., may require a specific test phase; please follow the procedures described in the operating instructions for each component.

To test the control unit, perform the following operations:

1. Function selection:
 - Set Dip Switch 1 to ON (Semi-automatic operation) and the remaining ones to OFF
2. Press the Open button and check that:
 - the flashing light is activated
 - the opening manoeuvre starts
 - the movement stops when the opening limit stop is reached.
3. Press the Close button and check that:
 - the flashing light is activated
 - the closing manoeuvre starts
 - the movement stops when the closing limit stop is reached.
4. Start an opening manoeuvre and make sure that during the manoeuvre the triggering of a device:
 - connected to the "Stop" input causes an immediate stop and a short reverse run
 - connected to the "Photo" input has no effect.
5. Start a closing manoeuvre and make sure that during the manoeuvre the triggering of a device:
 - connected to the "Stop" input causes an immediate stop and a short reverse run

- connected to the "Photo" input causes the stop and subsequent reversal of the manoeuvre
 - connected to the "Photo1" input causes the stop and subsequent reversal of the manoeuvre.
6. On the connected inputs, make sure that each activation of the input generates a step in the following sequence:
 - Step-by-step input: Sequence = Open – Stop – Close – Stop
 - Open input: Sequence = Open – Stop – Open – Stop
 - Close input: Sequence = Close – Stop – Close – Stop
 7. If the "Phototest" function is used, check the efficiency of the test:
 - Interrupt the "Photo" photocell, then start a manoeuvre and check that it is not performed
 - Interrupt the "Photo1" photocell, then start a manoeuvre and check that it is not performed
 - Short the "Photo" photocell contact, then start a manoeuvre and check that it is not performed
 - Short the "Photo1" photocell contact, then start a manoeuvre and check that it is not performed
 8. Perform the tests for measuring the Impact Forces as required by EN 12445.

If after the completion of the testing process additional functions are activated which could affect the safety of the system, specific testing of these functions must be performed.

6.1) Commissioning

Commissioning can take place only after all the testing phases of the control unit and the other devices have been completed successfully. It is not permissible to execute partial commissioning or to enable use of the system in makeshift conditions.

1. Prepare and store for at least 10 years the technical documentation for the automation, which must include at least the following: assembly drawing of the automation, wiring diagram, analysis of hazards and solutions adopted, manufacturer's declaration of conformity of all the devices installed (for A60 use the annexed CE declaration of conformity); copy of the instruction manual and maintenance schedule of the automation.
2. Affix a dataplate on the gate providing at least the following data: type of automation, name and address of manufacturer (person responsible for the "commissioning"), serial number, year of manufacture and "CE" marking.
3. Post a permanent label or sign near the gate detailing the operations for the release and manual manoeuvre.
4. Prepare the declaration of conformity of the automation system and deliver it to the owner.

5. Prepare the "Instructions and warnings for the use of the automation system" and deliver it to the owner.
6. Prepare the maintenance schedule of the automation system and deliver it to the owner (this must provide all directions regarding the maintenance of the single automation devices).
7. Before commissioning the automation system inform the owner in writing regarding residual risks and hazards (e.g. in the "Instructions and warnings for the use of the automation system").

7) Maintenance and Disposal

⚠ This charter provides information about how to draw up a maintenance schedule, and the disposal of A60.

7.1) Maintenance

The automation must undergo maintenance work on a regular basis, in order to guarantee prolonged lifetime.

The maintenance operations must be performed in strict compliance with the safety directions provided in this manual and according to the applicable legislation and standards.

If other devices are present, follow the directions provided in the corresponding maintenance schedule different from **A60**.

1. Is requires scheduled maintenance work every 6 months or 10.000 manoeuvres (max.) after previous maintenance.
2. Disconnect all power supplies.
3. Check for any deterioration of the components which form the automation, paying particular attention to erosion or oxidation of the structural parts. Replace any parts which are below the required standard.
4. Connect the electric power sources up again, and carry out the testing and checks stated in Paragraph "6 Testing".

7.2) Disposal

As in the case of installation, at the end of the product lifetime, disposal procedures must be carried out by qualified personnel.

This product comprises various types of materials, some of which can be recycled while others must be disposed of. Check information on the recycling and disposal procedures according to local legislation for this product category.

⚠ Some parts of the product may contain pollutant or hazardous substances; if disposed of into the environment these may constitute a serious risk of damage to the environment and public health.

As indicated by the symbol in figure never dispose of this product in domestic waste. Apply "classified waste collection" procedures for disposal in accordance with local regulations or return the product to the retailer when purchasing a new model.

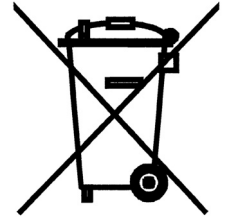

Local regulations may envisage serious fines in the event of illegal disposal of this product.

8) Accessories

RADIO card

The control unit features a connector for plugging in an SM radio card , which activates the inputs and allows the control unit to be remote-controlled through a transmitter.

output 1 STEP-BY-STEP
output 2 Open for pedestrians
output 3 Open
output 4 Close

9) Technical characteristics

With the aim of improving products, Nice S.p.a reserves the right to modify technical characteristics at any time without notice, while maintaining the same functionalities and intended use.

All technical characteristics stated refer to an ambient temperature of 20°C (±5°C).

Model type:	A60	A60/V1
Power	230 Vac ± 10%, 50 - 60 Hz	120 Vac ± 10%, 50 - 60 Hz
Maximum actuators power	300 W [1,3 A]	300 W [2,5 A]
Maximum flashing light power	100W	
Maximum frequency of operating cycles	unlimited	
Maximum time of continuous operation	unlimited	
Maximum current accessories (24 Vac)	200 mA	
Maximum current phototest output	75 mA	
Gate open indicator max. power SCA (24Vac)	2 W	
Maximum electric lock power 12 Vac	15 VA	
Working time	from 2,5 to 40 sec. (from 40 to 80 sec. with TLM)	
Pause time	from 5 to 80 sec.	
TRA opening delay time	0 or from 2.5 to 12 sec.	
TRC closing delay time	0 or from 2.5 to 12 sec.	
BALANCING manoeuvre times	from 0 to 8 sec.	
Force adjustment	from 0 to 100 %	
Operating temperature	-20 ÷ 50 °C	
Size	280 x 220 x 110 mm	
Weight	1,9 Kg	
Protection level	IP 55 (container undamaged)	

Congratulations for having chosen a Nice product for your automation system! Nice S.p.A. produces components for the automation of gates, doors, rolling gates, roller shutters and awnings: gearmotors, control units, radio controls, flashing lights, photocells and miscellaneous accessories. Nice uses only the finest materials and first-class workmanship. It focuses on the development of innovative solutions designed to simplify the use of its equipment, dedicating meticulous care to the study of its technical, aesthetic and ergonomic characteristics: From the wide range of Nice products, your installation technician will certainly have selected the one best suited to your specific requirements. However, Nice is not the producer of your automation system, which is rather the result of a combination of operations carried out by your installation technician, namely analysis, evaluation, selection of materials and system implementation. Each automation system is unique. Your installation technician is the only person who possesses the experience and professionalism needed to set up a system capable of satisfying your requirements, a system that is safe, reliable, long lasting and built in accordance with the regulations in force. An automation system is not only very convenient; it also improves the level of security in your home. Moreover, it will last for years with very little maintenance. Even though the automation system you possess meets the safety requirements of the legislation in force, this does not exclude the existence of a "residual risk", i.e. the possibility that dangers may arise, usually as a result of improper or unreasonable use. We have prepared the following list of do's and don'ts to help you avoid any mishaps:

- **Before using your automation system for the first time**, ask the installer to explain the origin of residual risks; take a few minutes and read the users **instructions manual given you by the installer**. Retain the manual for future use and deliver it to any subsequent owner of the automation system.
- **Your automation system is a machine that will faithfully execute your commands**; unreasonable or improper use may generate dangers: do not operate the system if there are people, animals or objects within its range of operation.
- **Children**: automation systems are designed to guarantee high levels of safety and security. They are equipped with detection devices that prevent movement if people or objects are in the way, guaranteeing safe and reliable activation. However, children should not be allowed to play in the vicinity of automated systems; to prevent any accidental activations, keep all remote controls away from children: **they are not toys!**
- **Photocells do not constitute actual safety devices, but safety aids**. They are designed using highly reliable technology, but in extreme conditions may be subject to malfunctions or potential faults, and in certain cases these faults are not immediately evident.

For this reason, it is good practice to observe the following:

- Transit is admitted only if the gate or door is completely open with the leaves stationary
- Transit while the gate or door is closing is **STRICTLY PROHIBITED!**

Periodically check correct operation of the photocells and perform the scheduled maintenance at least every six months.

- **Malfunctions**: If you notice that your automation is not functioning properly, disconnect the power supply to the system

and operate the manual release device. Do not attempt to make any repairs; call the installation technician and in the meantime, operate the system like a non-automatic door after releasing the gearmotor as described below.

- **Maintenance**: Like any machine, your automation needs regular periodic maintenance to ensure its long life and total safety. Arrange a periodic maintenance schedule with your installation technician. Nice recommends that maintenance checks be carried out every six months for normal domestic use, but this interval may vary depending on the intensity of use. Only qualified personnel are authorised to carry out checks, maintenance operations and repairs.
- Do not modify the system or its programming and adjustment parameters in any way, even if you feel capable of doing it: your installation technician is responsible for the system.
- The final test, the periodic maintenance operations and any repairs must be documented by the person who has performed them, these documents must remain under the custody of the owner of the system.

The only recommended maintenance operations that the user can perform periodically concern the cleaning of the photocell glasses and the removal of **leaves and debris that may impede the automation**. To prevent anyone from activating the gate release the automation system. Use a slightly damp cloth to clean.

- **Disposal**: At the end of its useful life, the automation must be dismantled by qualified personnel, and the materials must be recycled or disposed of in compliance with the legislation locally in force.
- **In the event of malfunctions or power failures**. While you are waiting for the technician to come or for the power to be restored if your system is not equipped with buffer batteries, you can operate the system like any non-automatic gate. In order to do this you need to manually release the gearmotor (this operation is the only one that the user of the automation is authorized to perform): This operation has been carefully designed by Nice to make it extremely easy, without any need for tools or physical exertion.
- **Replacing the Remote Control Battery**: if your radio control, after a period of time, seems not to work as well, or not to work at all, it may simply be that the battery is exhausted (depending on the type of use, it may last from several months up to one year and more). In this case you will see that the light confirming the transmission is weak, or does not come on, or comes on only briefly. Before calling the installation technician try exchanging the battery with one from another operating transmitter: if the problem is caused by a low battery, just replace it with another of the same type. The batteries contain polluting substances: do not dispose of them together with other waste but use the methods established by local regulations.

Are you satisfied? If you wish to install another automation system in your home, call your old installation technician and use Nice products. You will get the services of a specialist and the most advanced products available on the market, superior performances and maximum system compatibility. Thank you for reading these instructions. We feel confident that you will be well satisfied with your new system: for any present or future requirements, please contact your reliable installation technician.



Nice

Headquarter

Nice SpA

Oderzo TV Italia
Tel. +39.0422.85.38.38
Fax +39.0422.85.35.85
info@niceforyou.com

Nice in Italy

Nice Padova

Sarmeola di Rubano PD Italia
Tel. +39.049.89.78.93.2
Fax +39.049.89.73.85.2
infopd@niceforyou.com

Nice Roma

Roma Italia
Tel. +39.06.72.67.17.61
Fax +39.06.72.67.55.20
inforoma@niceforyou.com

Nice worldwide

Nice France

Buchelay
Tel. +33.(0)1.30.33.95.95
Fax +33.(0)1.30.33.95.96
info@fr.niceforyou.com

Nice Rhône-Alpes

Decines Charpieu France
Tel. +33.(0)4.78.26.56.53
Fax +33.(0)4.78.26.57.53
info@alps.niceforyou.com

Nice France Sud

Aubagne France
Tel. +33.(0)4.42.62.42.52
Fax +33.(0)4.42.62.42.50
infomarseille@fr.niceforyou.com

Nice Belgium

Leuven (Heverlee)
Tel. +32.(0)16.38.69.00
Fax +32.(0)16.38.69.01
info@be.niceforyou.com

Nice España Madrid

Tel. +34.9.16.16.33.00
Fax +34.9.16.16.30.10
info@es.niceforyou.com

Nice España Barcelona

Tel. +34.9.35.88.34.32
Fax +34.9.35.88.42.49
info@es.niceforyou.com

Nice Polska

Pruszków
Tel. +48.22.728.33.22
Fax +48.22.728.25.10
info@pl.niceforyou.com

Nice UK

Chesterfield
Tel. +44.87.07.55.30.10
Fax +44.87.07.55.30.11
info@uk.niceforyou.com

Nice Turkey

Istanbul
info@tr.niceforyou.com

Nice Romania

Cluj Napoca
Tel/Fax +40.264.45.31.27
info@ro.niceforyou.com

Nice Deutschland

Gelnhausen-Hailer
Tel. +49.60.51.91.52-0
Fax +49.60.51.91.52-119
info@de.niceforyou.com

Nice China

Shanghai
Tel. +86.21.575.701.46
+86.21.575.701.45
Fax +86.21.575.701.44
info@cn.niceforyou.com

Nice USA Inc.

Jacksonville, Fl.
Tel. +001.904.786.7133
Fax +001.904.786.7640
info@us.niceforyou.com