

Nice ToonaKit

For swing gates with leaves up to 3 m (Toona4), 5 m (Toona5) and 7 m (Toona7). Ideal for all requirements from residential to industrial applications.

Electromechanical gear motors, surface mounted, also in 24 Vdc version with magnetic encoder.

The 24 Vdc version with magnetic encoder and new control unit Moonclever (MC824H) equipped with BlueBUS technology, is designed for operation with the solar power system Solemyo.

Quality and durability thanks to the housing, made up of two tough aluminium shells with polyester paint finish; more resistant to atmospheric agents.

Bronze lead screw for **safe closure**.

Generously sized and practical connection compartment: rapid and easy access from above to internal parts located in the upper section of the motor.

24 Vdc version with magnetic encoder, perfect for intensive use

- easy programming by pressing a single button
- clutch with anti-crush safety feature
- automatic memorization of limit switches in opening and closing with self-learning function
- pause time programming; partial opening; slowdown during opening and closing
- the system will operate during a blackout by means of rechargeable batteries



Technical specifications	T04006	T04024	T05016	T05024	T07024
Power (Vac 50 Hz)	230	-	230	-	-
(Vdc)	-	24	-	24	-
Max. absorption (A)	1.5	5	1.5	5	-
Nominal absorption (A)	1	2	1	2	2.5
Max. absorbed power (W)	340	120	340	120	-
Nominal absorbed power (W)	180	48	180	60	-
Built-in capacitor (µF)	7	-	7	-	-
Protection level (IP)	44				
Speed under no load (m/s)	0.016		0.013	0.016	0.013
Speed under load (m/s)	0.012		0.010	0.012	0.011
Travel (mm)	385	350	505	540	584
Max. force (N)	1800				2700
Nominal force (N)	600				1400
Working temp. (°C Min/Max)	-20 ÷ +50				
Thermal cut-out (°C)	140		-		
Work cycle (cycle/hour)	58	95	22	95*	41*
Insulation class	F			A	F
Dimensions (mm)	820x115x105		965x115x105		1200x128x150
Weight (kg)	6		7		15

* with optimal installation

Dimensions

Toona4

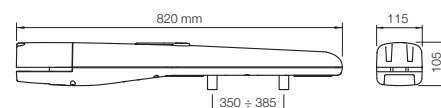

Toona5

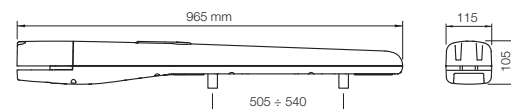

Toona7

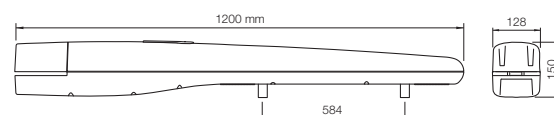

Utilisation limits

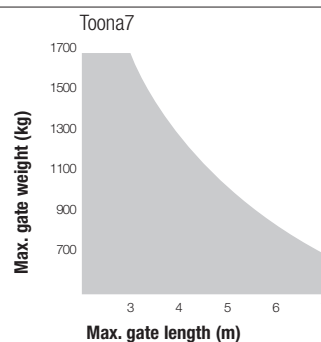
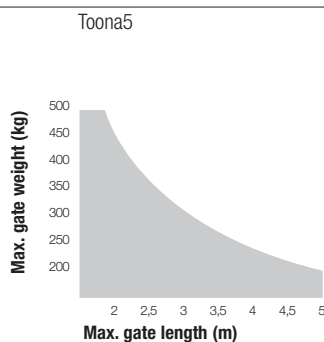
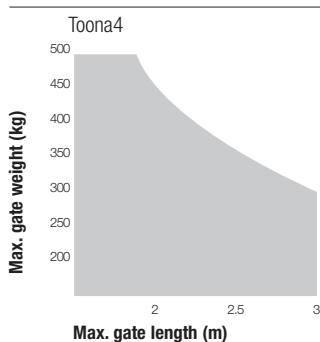

The shape, the height of the gate and the weather conditions can considerably reduce the values shown in the graph to the side.

Use in windy areas 230 Vac models.

ToonaKit 7

Up to 5 m, including:

Nice Price **£ 785.00**

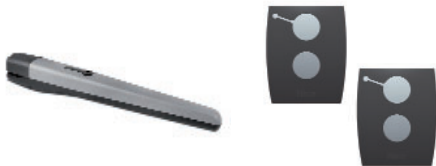

TO5024

one irreversible
electromechanical
gear motors, 24 Vdc,
with magnetic encoder,
mechanical stop in
opening
1 pcs

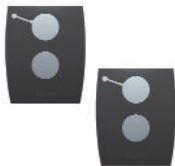

ON2

two transmitters
433.92 MHz,
2 channels
2 pcs



MC824H

control unit
for two motors,
with 24 Vdc encoder
1 pc



MOFB

one couple of outdoor
photocells designed
for connection
via Nice BlueBUS
1 pc



OXI

receiver up to 4 channels
with connector, without
built-in transmitter
1 pc

ToonaKit 8

Up to 7 m, including:

Nice Price £ 1,065.00



T07024

one irreversible
electromechanical
gear motors, 24 Vdc,
with magnetic encoder,
mechanical stop in
opening and closing
1 pcs



ON2

two transmitters
433.92 MHz,
2 channels
2 pcs

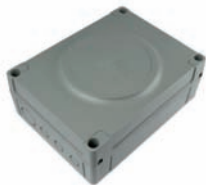

MC824H

control unit
for two motors,
with 24 Vdc encoder
1 pc



MOFB

one couple of outdoor
photocells designed
for connection
via Nice BlueBUS
1 pc



OXI

receiver up to 4 channels
with connector, without
built-in transmitter
1 pc

Toona

Swing gate opener

series 4

series 5

series 7



EN - Instructions and warnings for installation and use

IT - Istruzioni ed avvertenze per l'installazione e l'uso

FR - Instructions et avertissements pour l'installation et l'utilisation

ES - Instrucciones y advertencias para la instalación y el uso

DE - Installierungs-und Gebrauchsanleitungen und Hinweise

PL - Instrukcje i ostrzeżenia do instalacji i użytkowania

NL - Aanwijzingen en aanbevelingen voor installatie en gebruik

Nice

This product has been designed to automate gates or doors with leaf opening, for residential or industrial use. **CAUTION! – Any other use different to that described and in ambient conditions different to those set out in this manual is to be considered improper and forbidden!**

The product is an electromechanical gear motor, equipped with a 24 v continuous current or 230V (depending on the model) alternate current motor and an endless screw reduction gear.

The gear motor is powered by the external control unit to which it is connected. In the event of a black out, it is possible to move the gate leaves by hand, unblocking the gear motor manually.

Fig. 1 shows all the components provided in the package (according to the model chosen):

- [a] - electromechanical gear motor
- [b] - front bracket (for fixing the gear motor to the gate leaf)
- [c] - rear bracket and plate (for fixing the gear motor to the wall)
- [d] - metal parts (screws, washers, etc.)
- [e] - keys to manually unlock the gear motor

1 GENERAL SAFETY WARNINGS AND PRECAUTIONS

Safety warnings

- **CAUTION!** - This manual contains important instructions and warnings for personal safety. Wrong installation can cause serious injuries. Before starting work read all the manual carefully. If in doubt, stop installation and ask the Nice Assistance Department for clarifications.
- **CAUTION!** – According to the most recent European legislation, the realisation of an automatic door or gate must comply with the regulations of Directive 98/37/CE (Machine Directive) and in particular, standards EN 12445; EN 12543; EN 12635 and EN 13214-1, which declare the presumed conformity of the automation. **In consideration of this, all the installation, connection, inspection and maintenance operations of the product must be performed exclusively by a qualified and competent technician!**
- **CAUTION!** – Important instructions: keep this manual for any possible future requirement for maintenance and disposal of the product.

Warnings for installation

- Before installing check if this product is suited to automating your gate or door (see chapter 3 and “Technical features of the product”). If unsuitable, DO NOT proceed with the installation.
- Include a disconnection device in the power supply system with an opening distance between the contacts to permit full disconnection in the conditions dictated by the category of surcharge III.
- **All the installation and maintenance operations must occur with the automation disconnected from the electrical power supply.** If the disconnection device of the power supply is not visible from the area where the automatism is located, before starting the work it is necessary to attach a sign with the text “CAUTION! MAINTENANCE IN PROGRESS” on the disconnection device.
- During installation handle the automatism with care avoiding crushing, knocks, falls or contact with liquids of any kind. Do not place the product near sources of heat, or expose it to naked flames. All these activities can damage and cause malfunctions or dangerous situations. If this occurs, stop the installation immediately and contact the Nice Assistance Department.
- Do not make alterations to any part of the product. Operations which are not permitted will cause only malfunctions. The manufacturer declines any liability for damage caused by arbitrary alterations to the product.
- If the gate or the door to be automated is fitted with a pedestrian door it is necessary to include a control system in the installation to prevent the operation of the motor when the pedestrian door is open.
- Check there are no trapping points towards fixed parts when the leaf of the gate is in the maximum *Open* position, if necessary protect these parts.
- The push button control on the wall must be positioned in sight of the automation, away from the moving parts, at a minimum height of 1.5 m from the ground and it must not be accessible to the public.
- The product packaging material must be disposed of respecting the local regulations in force.

3 INSTALLATION

3.1 - Checks before installation

Before installation, check the integrity of the components, suitability of the model chosen and suitability of the environment chosen for the installation.

IMPORTANT – The gear motor cannot automate a manual gate which does not have a safe and efficient mechanical structure. Furthermore, it cannot solve the faults caused by wrong installation or bad maintenance of the gate itself.

3.2 - Suitability of the gate to being automated and the surrounding environment

- Check the mechanical structure of the gate is suited to being automated and conforms to the national laws in force (*if necessary make reference to the data on the gate label*).
- Moving the gate leaf manually in Open and Close position, check the movement occurs with equal and constant attrition at each point of the stroke (*there must be no moments of greater effort*).
- Check the gate leaf remains balanced, that it does not move if brought manually to any position and left stopped.
- Check the space around the gear motor allows to manually unblock the gate leaf, easily and safely.
- Check the surfaces chosen for installing the product are solid and can guarantee stable fixing.
- Check the fixing zone of the gear motor is compatible with the size of the latter, see **fig. 2**: the correct *Opening* movement of the gate and the force the motor exerts to perform it, depend on the position in which the rear fixing bracket is secured. Therefore, before installing it is necessary to make reference to **graph 2** to define the maximum *Opening* angle of the leaf and the force of the motor, suited to the individual system.

3.3 - Limits of use of the product

Before installing the product, check the gate leaf is the right size and weight and falls within the limits shown in **graph 1**.

3.4 - Preparing for installation

Fig. 3 shows an example of an automation system designed with Nice components. These components are positioned according to a typical and usual scheme.

Making reference to **fig. 3**, decide the approximate position in which to install each component envisaged by the system and the most appropriate connection diagram.

Useful components for producing a complete system (fig. 3):

- 1 - Electromechanical gear motors
- 2 - Couple of photocells
- 3 - Couple of stop blocks (in Opening)
- 4 - Columns for photocells
- 5 - Flashing signalling device with incorporated antenna
- 6 - Key selector switch or digital keypad
- 7 - Vertical electrical locking (only for reversible models)
- 8 - Control unit

3.5 - Installation of fixing brackets and gear motor

3.5.1 - Installation of rear fixing bracket

Calculate the position of the rear bracket using **graph 2**.

This graph serves to establish **dimensions A and B** and the **value of the maximum opening angle** of the leaf. **Important** – The values of **A and B** must be similar to allow linear movement of the automation.

01. Measure **dimension C** (fig. 4) on the fixing side;

02. On **graph 2**, identify **dimension C** found and trace a **horizontal line** that determines the value of **dimension B (*)** as shown in the example of **fig. 5**; the meeting point with line "r.i.1" (installation line recommended) determines the value of the angle of maximum opening. From this point, trace a **vertical line** as shown in the example of **fig. 5** to determine the value of **dimension A**.

If the angle found does not correspond to the requirements, adapt **dimension A** and if necessary **dimension B**, so they are similar.

(*) Do not use values of dimension B below the line "t" (see graph 2).

03. Before being fixed to the wall the bracket must be sealed to the specific fixing plate (**fig. 7**); if necessary the bracket can be cut adapting values of dimensions **A and B**.

Note – The bracket supplied for the **Toona series 4-5 gear motor**, measures **150 mm** in length; in the event of special applications or in the event of a gate equipped with external opening (**fig. 6**) use bracket mod. **PLA6** (accessory).

CAUTION! – Before securing the rear bracket, check the fixing zone of the front bracket is in a solid part of the leaf, as this bracket must be fixed at a different height of the rear bracket (**fig. 8**).

04. At this point, fix the bracket using dowels, screws and washers required (not supplied).

3.5.2 - Installation of front fixing bracket

The front bracket must be fixed to the gate leaf respecting the values of **dimensions D and E** (**Fig. 4**).

Note – The bracket supplied for the **Toona series 4-5 gear motor** must be welded directly to the gate leaf. If this is not possible, use bracket mod. **PLA8** (accessory).

01. Establish the value of **dimension E** using **Table 1**;

02. Establish the height in which to position the front bracket, referring to **fig. 8**;

03. Fix the bracket to the solid part of the gate leaf.

3.5.3 - Installation of the gear motor on the fixing brackets

• Installing the gear motor on the rear bracket:

01. Fix the gear motor to the bracket as shown in **fig. 9** using the screw, washer and nut supplied;

02. Tighten the nut to the end and then loosen by 1/10 of a turn to allow minimum clearance between the parts.

• Installing the gear motor on the front bracket:

01. Fix the gear motor to the bracket as shown in **fig. 10** using the screw, washer and nut supplied;

02. Tighten the screw to the end.

03. Fix the label provided in the package, dealing with the unblocking and blocking operations of the gear motor, permanently close to the gear motor

3.6 - Setting the mechanical limit switch

The mechanical limit switch allows to set the stop position of the gate leaf, in this way, it is not necessary to use the stop blocks and the leaf does not hit against these at the end of the manoeuvre.

• Toona series 4-5 (24 V)

WARNING – In the event of applications with a gate equipped with opening towards the outside (**fig. 6**) it is necessary to invert the power supply wires. Set the **limit switch in Opening** of the gear motor as follows:

01. Unblock the gear motor as shown in **fig. 16**;

02. Loosen the mechanical stop screw;

03. Bring the gate leaf manually to the *Open* position required;

04. Then, bring the mechanical stop to the end of the pin and block the screw (**fig. 11**).

05. Bring the leaf manually to the *Close* position and block the gear motor.

Note – Gear motors mod. **TO4006** and mod. **TO5016**, are provided with a **mechanical limit switch also for the Closing manoeuvre**. If in possession of one of these models, to set the mechanical limit switch repeat the procedure described above, with a variation at **point 03**, in this case, bring the gate leaf manually in the required *Closing* position.

• Toona series 4-5 (230 V)

The **Toona series 4-5 gear motors** arranged for an alternate current of 230V, come with mechanical stop with micro switch which, on contact with the pin interrupts the electrical power supply. **WARNING** – In the event of applications with a gate equipped with opening towards the outside (**fig. 6**) it is necessary to invert the power supply wires.

• Toona series 7

Set the **limit switch in Opening** and **Closing** of the gear motor;

01. Unblock the gear motor as shown in **fig. 16**;

02. Move the leaf manually until the mechanical stop screw is visible and loosen the screw;

03. Bring the gate leaf manually to the *Open* position required;

04. Then, bring the mechanical stop to the end of the pin and block the screw (**fig. 12**);

05. At this point repeat this procedure bringing the leaf manually to the position of maximum *Closure*, to set the limit switch in *Closure*;

06. Finally, block the gear motor.

TABLE 1

	Toona 4					Toona 5					Toona 7
	TO4005	TO4006	TO4015	TO4605	TO4024	TO5015	TO5016	TO5605	TO5024	TO5024I	TO7024
D (mm):	730	695	730	730	730	880	845	880	880	880	1070
A (mm)	E (mm)					E (mm)					E (mm)
100	630	595	630	630	630	780	745	780	780	780	
110	620	585	620	620	620	770	735	770	770	770	
120	610	575	610	610	610	760	725	760	760	760	
130	600	565	600	600	600	750	715	750	750	750	
140	590	555	590	590	590	740	705	740	740	740	
150	580	545	580	580	580	730	695	730	730	730	
160	570	535	570	570	570	720	685	720	720	720	
170	560	525	560	560	560	710	675	710	710	710	
180	550	515	550	550	550	700	665	700	700	700	890
190	540	505	540	540	540	690	655	690	690	690	880
200	530	495	530	530	530	680	645	680	680	680	870
210	520	485	530	530	530	670	635	670	670	670	860
220						660	625	660	660	660	850
230						650	615	650	650	650	840
240						640	605	640	640	640	830
250						630	595	630	630	630	820
260						620	585	620	620	620	810
270						610	575	610	610	610	800
280						600	565	600	600	600	790

4 ELECTRICAL CONNECTIONS

CAUTION!

– A wrong connection can cause faults or danger; therefore follow scrupulously the connections set out.

– Perform the connection operations when the electricity is off.

To connect the gear motor to the control unit, proceed as follows:

01. Remove the lid of the gear motor as shown in **fig. 13**;
02. Loosen the cableway of the gear motor and insert the connecting cables inside it (**fig. 14**);
03. Connect the various wires and grounding cable, exactly as shown in the wiring diagram of **fig. 15**;
04. Replace lid on gear motor.

To check the connections, direction of rotation of the motor, phase shift in the movement of the leaves and setting the limit switch, refer to the instructions manual of the control unit.

IMPORTANT – With a gate configured with opening towards the outside invert the power supply wires with respect to the standard installation.

5 INSPECTING THE AUTOMATION

This is the most important phase in realising the automation to guarantee maximum safety. The inspection can be used also to periodically check the devices which make up the automatism.

The inspection of the entire system must be performed by expert and qualified staff who must take responsibility of the tests requested, depending on the risk involved and to check compliance of what is set out by laws, rules and regulations and in particular all the requirements of regulation EN 12445 which establishes the testing methods to verify gate automatisms.

Inspection

Each single component of the automatism, for example sensitive edges, photocells, emergency shutdowns, etc. requires a specific inspection phase; for these devices follow the procedures shown in the respective instruction manuals. For inspection of the gear motor follow the operations below:

01. Check that everything in this manual and in particular in chapter 1 has been rigorously complied with;
02. Unblock the gear motor as shown in **fig. 16**;
03. Check it is possible to manually move the leaf when opening and closing with a force no greater than 390N (approx. 40 kg);
04. Block the gear motor and connect the electrical power supply;
05. Using the control or shutdown devices envisaged (key selector switch, control buttons or radio transmitters), perform a number of opening, closing and stopping tests of the gate and check it behaves as it should;
06. Check the correct operation of all the safety devices one by one in the system (photocells, sensitive edges, emergency shutdown, etc.) and check the gate behaves as it should;
07. Command a closing manoeuvre and check the force of the impact of the leaf against the end of the mechanical limit switch. If necessary, try to unload the pressure, finding a setting which gives better results;
08. If the dangerous situations caused by the movement of the leaf have been protected by limiting the force of impact the force must be measured as required by regulation EN 12445;

Note – The gear motor is not provided with torque setting devices, such regulations are done by the Control unit.

Putting into operation

This can occur only after having performed, with positive results, all the inspection phases of the gear motor and other devices present. To put it into operation refer to the instructions manual of the control unit.

IMPORTANT – It is forbidden to put into partial or provisional operation.

6 PRODUCT MAINTENANCE

To keep the level of safety consistent and to guarantee maximum life of the entire automation it is necessary to maintain it regularly.

The maintenance must be performed in line with the safety instructions of this manual and according to what is set out by the laws and regulations in force. For the gear motor a programmed maintenance within no more than 6 months is required.

Maintenance operations:

01. Disconnect any sources of electricity.
02. Check the status of deterioration of all the materials which make up the automation with particular attention to signs of erosion or oxidation of the structural parts: replace the parts which do not provide sufficient guarantees.
03. Check the screw connections are sufficiently tight.
04. Check the bolt and endless screw are suitably greased.
05. Check the wear of the moving parts and, if necessary, replace used parts.
06. Reconnect the sources of electrical power and perform all the tests and checks envisaged in chapter 5.

For the other devices present in the system refer to the individual instruction manuals.

DISPOSAL OF THE PRODUCT

This product is an integral part of the automation, and therefore, they must be disposed of together.

As for the installation operations, at the end of the life of this product, the dismantling operations must be performed by qualified personnel.

This product is made from different types of materials: some can be recycled, others must be disposed of. Please inform yourselves on the recycling or disposal systems provided for by the laws in force in your area, for this category of product.

CAUTION! – some parts of the product can contain polluting or dangerous substances which, if dispersed in the environment, may cause serious harm to the environment and human health.

As indicated by the symbol at the side, it is forbidden to throw this product into domestic refuse. Therefore, follow the “separated collection” instructions for disposal, according to the methods provided for by local regulations in force, or redeliver the product to the retailer at the moment of purchase of a new, equivalent product.



CAUTION! – the regulations in force at local level may envisage heavy sanctions in case of abusive disposal of this product.

TECHNICAL FEATURES OF THE PRODUCT

CAUTIONS: • The technical features set out refer to an ambient temperature of 20°C (± 5°C). • Nice S.p.a. reserves the right to make alterations to the product any time it deems it necessary, keeping the same functionality and destination of use.

Toona series 4					
	TO4005	TO4006	TO4015	TO4605	TO4024
Type	electromechanical gear motor for gates or doors with leaf opening				
Power input	230 Vac 50 Hz	230 Vac 50 Hz	230 Vac 50 Hz	230 Vac 50 Hz	24 Vdc
Maximum absorption	1.5 A	1.5 A	1.5 A	1.3 A	5 A
Nominal absorption	1 A	1 A	1 A	0,9 A	2 A
Maximum absorbed power	340 W	340 W	340 W	300 W	120 W
Nominal absorbed power	180 W	180 W	180 W	160 W	48 W
Capacitor incorporated	7 µF	7 µF	7 µF	7 µF	-
Protection grade	IP 44	IP 44	IP 44	IP 44	IP 44
Travel	385 mm	350 mm	385 mm	385 mm	385 mm
Speed loadless	0,016 m/sec	0,016 m/sec	0,013 m/sec	0,016 m/sec	0,016 m/sec
Speed loaded	0,012 m/sec	0,012 m/sec	0,010 m/sec	0,012 m/sec	0,012 m/sec
Maximum force	1800 N	1800 N	1800 N	1800 N	1800 N
Nominal force	600 N	600 N	600 N	600 N	600 N
Operating temperature	-20 °C to +50 °C	-20 °C to +50 °C	-20 °C to +50 °C	-20 °C to +50 °C	-20 °C to +50 °C
Thermal protection	140 °C	140 °C	140 °C	140 °C	-
Cycles/h at nominal force	58	58	54	50	95
Durability	estimated between 80,000 and 250,000 cycles of manoeuvres according to the conditions set out in Table 2				
Insulation class	F	F	F	F	F
Dimensions (mm)	820 x 115 x 105 h	820 x 115 x 105 h	820 x 115 x 105 h	820 x 115 x 105 h	820 x 115 x 105 h
Weight	6 Kg	6 Kg	6 Kg	6 Kg	6 Kg

Toona series 5					
	TO5015	TO5016	TO5605	TO5024	TO5024I
Type	electromechanical gear motor for gates or doors with leaf opening				
Power input	230 Vac 50 Hz	230 Vac 50 Hz	230 Vac 50 Hz	24 Vdc	24 Vdc
Maximum absorption	1,5 A	1,5 A	1,3 A	5 A	5 A
Nominal absorption	1 A	1 A	0,9 A	2 A	2,2 A
Maximum absorbed power	340 W	340 W	300 W	120 W	120 W
Nominal absorbed power	180 W	180 W	160 W	48 W	60 W
Capacitor incorporated	7 µF	7 µF	7 µF	-	-
Protection grade	IP 44	IP 44	IP 44	IP 44	IP 44
Travel	540 mm	505 mm	540 mm	540 mm	540 mm
Speed loadless	0,013 m/sec	0,013 m/sec	0,016 m/sec	0,016 m/sec	0,013 m/sec
Speed loaded	0,010 m/sec	0,010 m/sec	0,012 m/sec	0,012 m/sec	0,010 m/sec
Maximum force	1800 N	1800 N	1800 N	1800 N	2200 N
Nominal force	600 N	600 N	600 N	600 N	800 N
Operating temperature	-20 °C to +50 °C	-20 °C to +50 °C	-20 °C to +50 °C	-20 °C to +50 °C	-20 °C to +50 °C
Thermal protection	140 °C	140 °C	140 °C	-	-
Cycles/h at nominal force	54	54	50	95	75
Durability	estimated between 80,000 and 250,000 cycles of manoeuvres according to the conditions set out in Table 2				
Insulation class	F	F	F	F	F
Dimensions (mm)	965 x 115 x 105 h	965 x 115 x 105 h	965 x 115 x 105 h	965 x 115 x 105 h	965 x 115 x 105 h
Weight	7 Kg	7 Kg	7 Kg	7 Kg	8 Kg

Toona series 7

	TO7024
Type	electromechanical gear motor for gates or doors with leaf opening
Power input	24 Vdc
Maximum absorption	5 A
Nominal absorption	2.5 A
Maximum absorbed power	120 W
Nominal absorbed power	60 W
Protection grade	IP 44
Travel	584 mm
Speed loadless	0.013 m/sec
Speed loaded	0.011 m/sec
Maximum force	2700 N
Nominal force	1400 N
Operating temperature	-20 °C to +50 °C
Cycles/h at nominal force	41
Durability	estimated between 80,000 and 250,000 cycles of manoeuvres according to the conditions set out in Table 2
Insulation class	F
Dimensions (mm)	1200 x 128 x 150 h
Weight	15 Kg

Durability of the product

Durability is the average economic life of the product. The value of durability is strongly influenced by the demand index of the manoeuvres performed by the automatism: that is the sum of all the factors which contribute to the wear of the product (see Table 2).

To establish the probable durability of your automatism proceed as follows:

01. Calculate the demand index summing the values in percentage of the entries present in **Table 2** to each other;

02. In **Graph A**, from the value just found, trace a vertical line until you intersect the curve; from this point trace a horizontal line to cross the line of “cycles of manoeuvres”. The value established is the estimated durability of your product.

The estimate of durability is performed on the basis of the design calculations and the results of tests carried out on prototypes. In fact, being an estimate, it does not give any guarantee on the actual duration of the product.

		Demand index		
		Toona 4	Toona 5	Toona 7
Leaf weight:	> 200 Kg	10 %	0 %	0 %
	> 300 Kg	20 %	10 %	0 %
	> 400 Kg	30 %	20 %	10 %
	> 500 Kg	-	30 %	20 %
Leaf length:	2 - 3 m	20 %	0 %	0 %
	3 - 4 m	-	10 %	0 %
	4 - 5 m	-	20 %	10 %
	5 - 6 m	-	-	20 %
	6 - 7 m	-	-	30 %
Ambient temperature greater than 40°C or lower than 0°C or humidity greater than 80%		20 %	20 %	20 %
Blind leaf:		15 %	15 %	15 %
Installation in windy area:		15 %	15 %	15 %

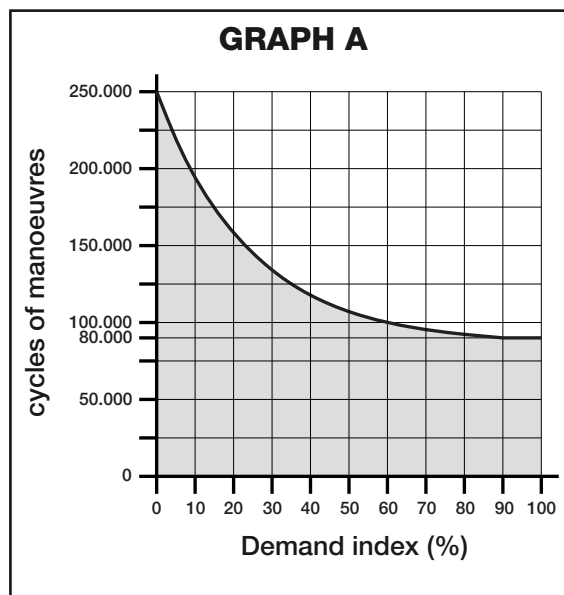

Example of calculation of durability of a Toona series 5 gear motor (refer to Table 2 and Graph A):

- leaf weight = 350 Kg (demand index= 10%)

- leaf length = 3.5 m (demand index = 10%)

- no other stress elements present

Total demand index = 20%

Durability estimate = 160,000 cycles of manoeuvre

CE DECLARATION OF CONFORMITY

Note: The content of this declaration corresponds to what is declared in the official document, dated 23rd April 2008, deposited at the premises of Nice Spa and, specifically, at its last review available before this manual was printed. The text here has been readapted for editorial purposes.

Number: 288/TO

Review: 0

The undersigned, Lauro Buoro, in his capacity of Managing Director, declares under his sole responsibility that the product:

Manufacturer: NICE s.p.a.

Address: Via Pezza Alta 13, Z.I. Rustignè, 31046 Oderzo (TV) Italia

Type: Electromechanical gear motor TOONA series

Models: TO4005, TO4006, TO4015, TO4024, TO4605, TO5015, TO5016, TO5024, TO5024I, TO5605, TO5624, TO7024

Accessories:

Conforms to the following community directives:

- 98/37/CE (89/392/CEE amended) DIRECTIVE 98/37/CE OF THE EUROPEAN PARLIAMENT AND COUNCIL dated 22nd June 1998 on the rapprochement of legislations on member States relevant to machines.

As provided for by directive 98/37/CE it is cautioned that it is forbidden to put into operation the product indicated above until the machine, in which the product is incorporated, has been identified and declared conformant with directive 98/37/CE.

Furthermore, the product conforms to what is provided for by the following community directives, as amended by Directive 93/68/CEE of the council dated 22nd July 1993:

2006/95/CEE (past directive 73/23/CE) DIRECTIVE 2006/95/CE OF THE EUROPEAN PARLIAMENT AND COUNCIL dated 12th December 2006 concerning rapprochement of the legislations of member states on electrical material for use within certain voltage limits

According to the following harmonised laws: EN 60335-1:1994+A11:1995+A1:1996+A12:1996 +A13:1998+A14:1998+A15:2000 +A2:2000+A16:2001

- 2004/108/CEE (past directive 89/336/CEE) DIRECTIVE 2004/108/CE OF THE EUROPEAN PARLIAMENT AND COUNCIL of 15th December 2004 concerning rapprochement of the legislations of member states on electromagnetic compatibility and which abrogates directive 89/336/CEE

According to the following harmonised laws: EN 61000-6-2:2005; EN 61000-6-3:2001+A11:2004

Furthermore, it conforms limited to the applicable parts, to the following standards:

EN 60335-1:2002+A1:2004+A11:2004+A12:2006+ A2:2006, EN 60335-2-103:2003, EN 13241-1:2003; EN 12453:2002;

EN 12445:2002; EN 12978:2003

Oderzo, 23rd April 2008

Lauro Buoro (Managing Director)



EN - Images

IT - Immagini

FR - Images

ES - Imágenes

DE - Bilder

PL - Zdjęcia

NL - Afbeeldingen

- EN - **GRAPH 1** "Limits of use of the product"
- FR - **GRAPHIQUE 1** "Limites d'utilisation du produit"
- DE - **GRAPHIK 1** "Verwendungsgrenzen des Produkts"
- NL - **GRAFIEK 1** "Gebruiksbeperkingen van het product"

- IT - **GRAFICO 1** "Limiti d'impiego del prodotto"
- ES - **GRÁFICO 1** "Límites de empleo del producto"
- PL - **SCHEMAT 1** "Ograniczenia używania produktu"

Toona 4

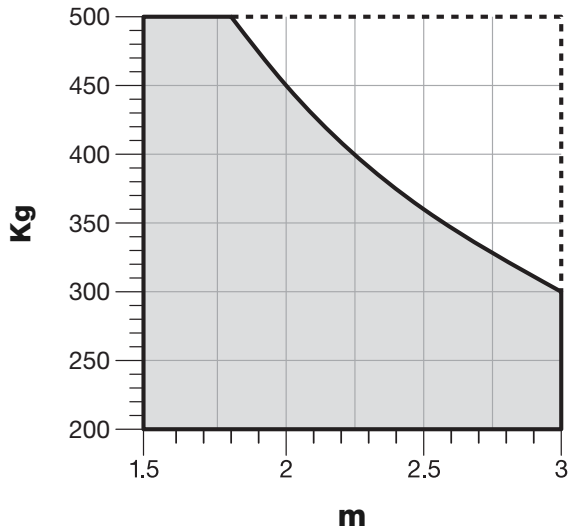

Kg:

- EN - Maximum weight of the gate leaf
- IT - Peso massimo dell'anta del cancello
- FR - Poids maximum du vantail du portail
- ES - Peso máximo de la hoja de la puerta
- DE - Höchstgewicht des Torflügels
- PL - Ciężar maksymalny skrzydła bramy
- NL - Maximum gewicht van de vleugel van het hekwerk

m:

- EN - Maximum length of the gate leaf
- IT - Lunghezza massima dell'anta del cancello
- FR - Longueur maximum du vantail du portail
- ES - Longitud máxima de la hoja de la puerta
- DE - Höchstlänge des Torflügels
- PL - Długość maksymalna skrzydła bramy
- NL - Maximum lengte van de vleugel van het hekwerk

Toona 5

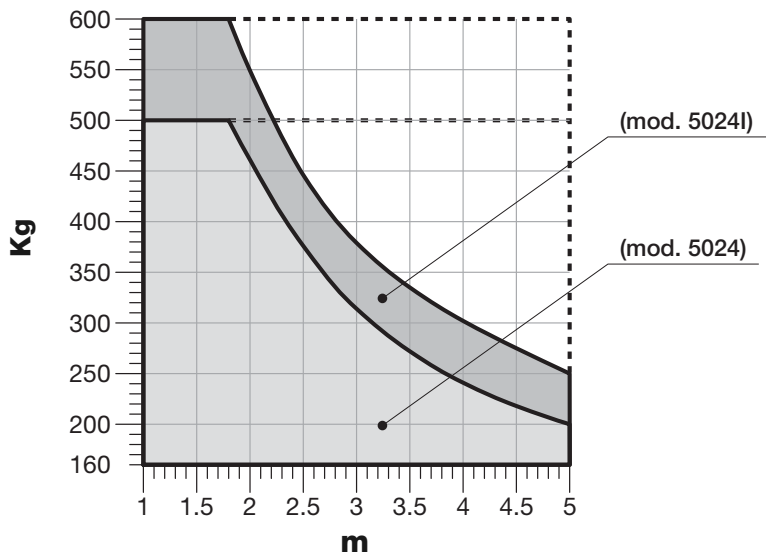

Toona 7

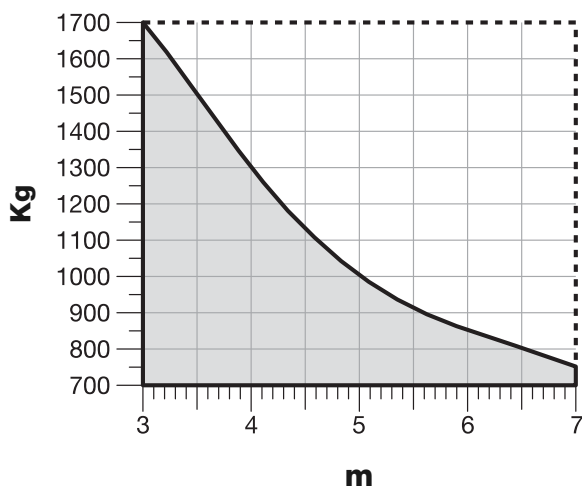

TO4006

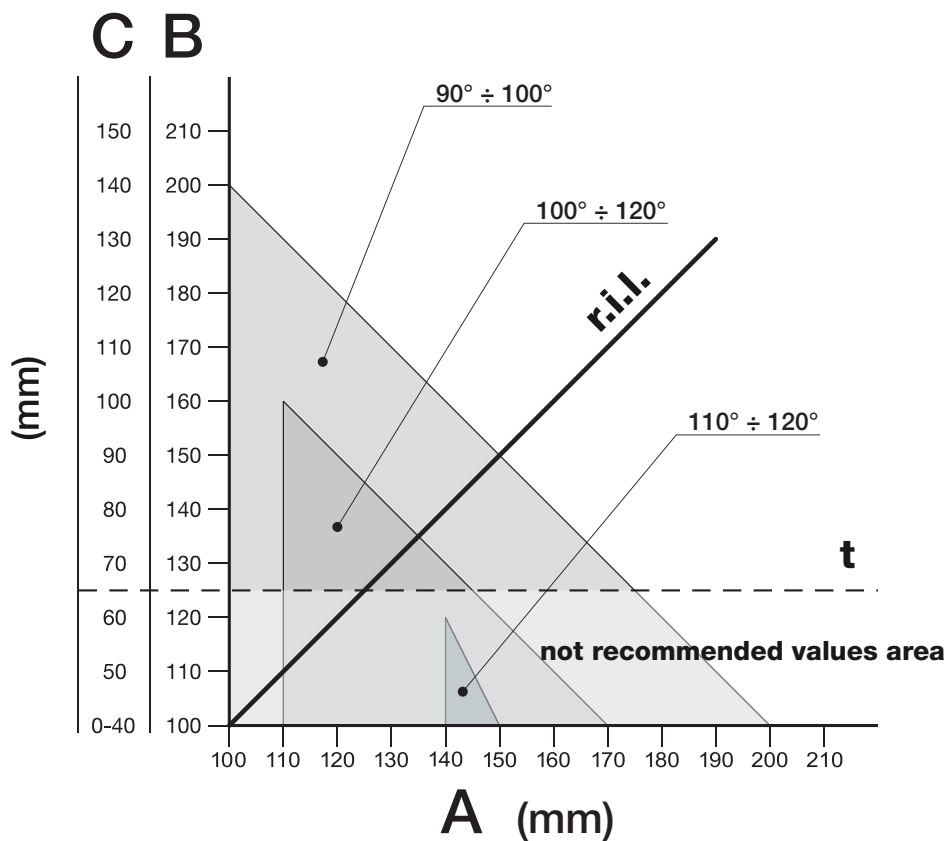

TO4005 - TO4015 - TO4024 - TO4605

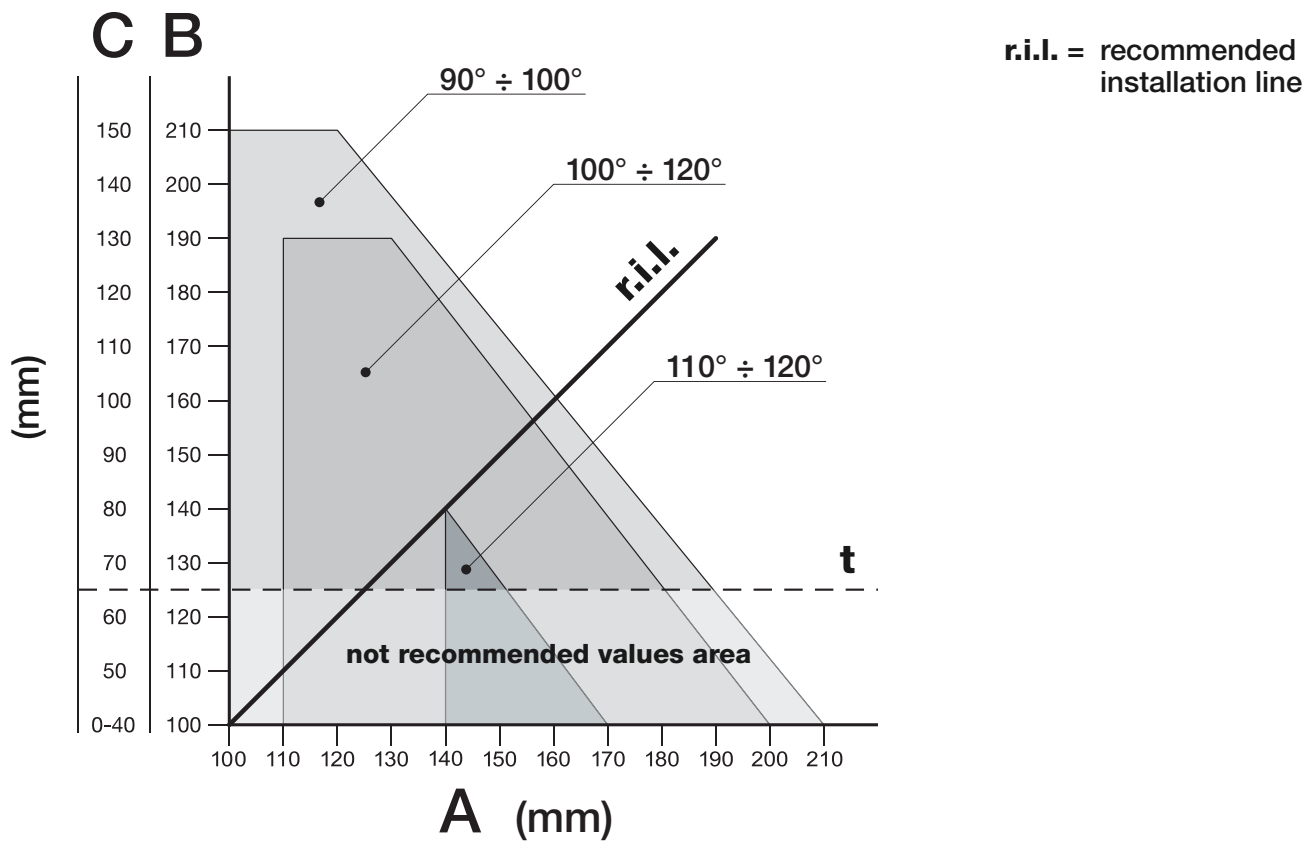

TO5015 - TO5605 - TO5024 - TO5024I

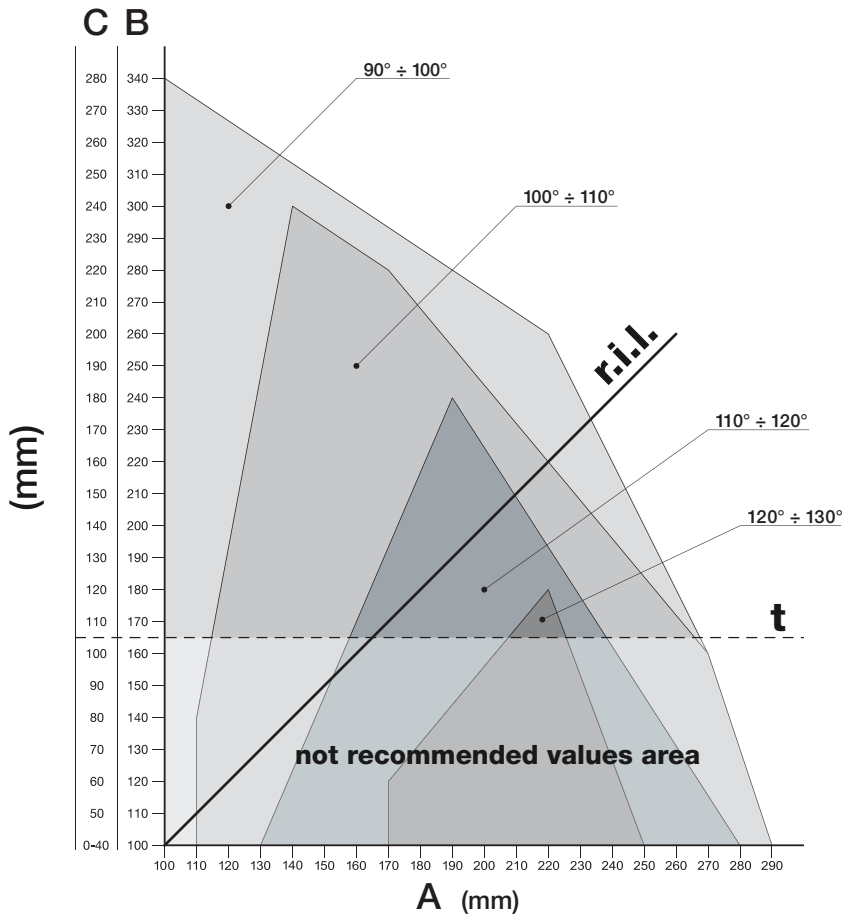

r.i.l. = recommended installation line

TO5016

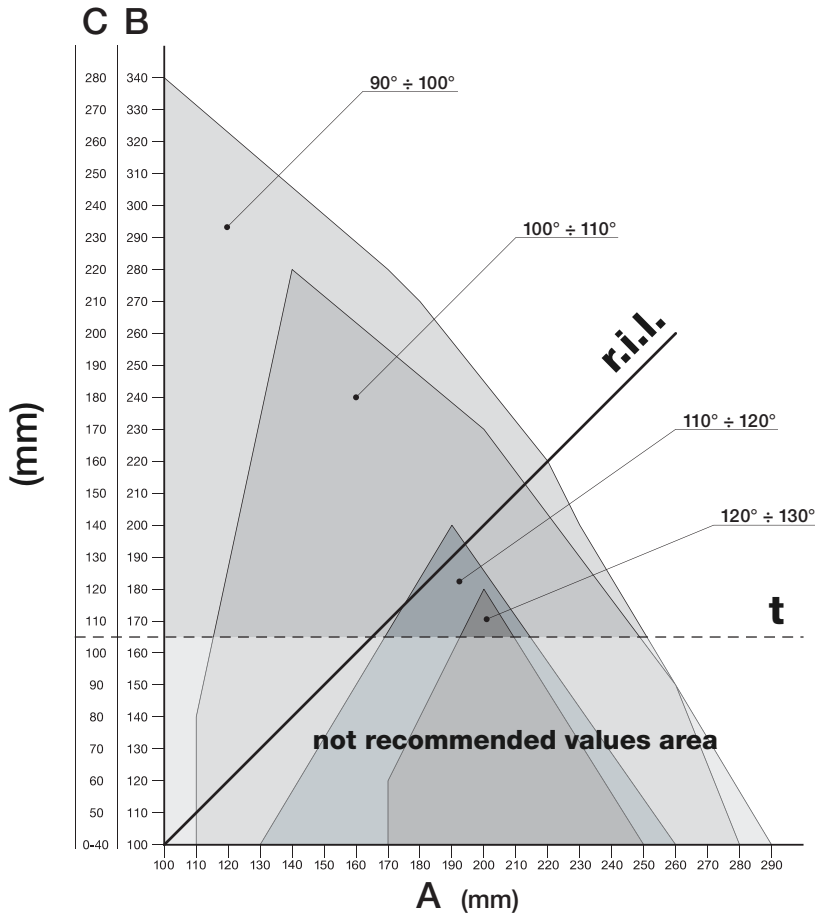

r.i.l. = recommended installation line

T07024

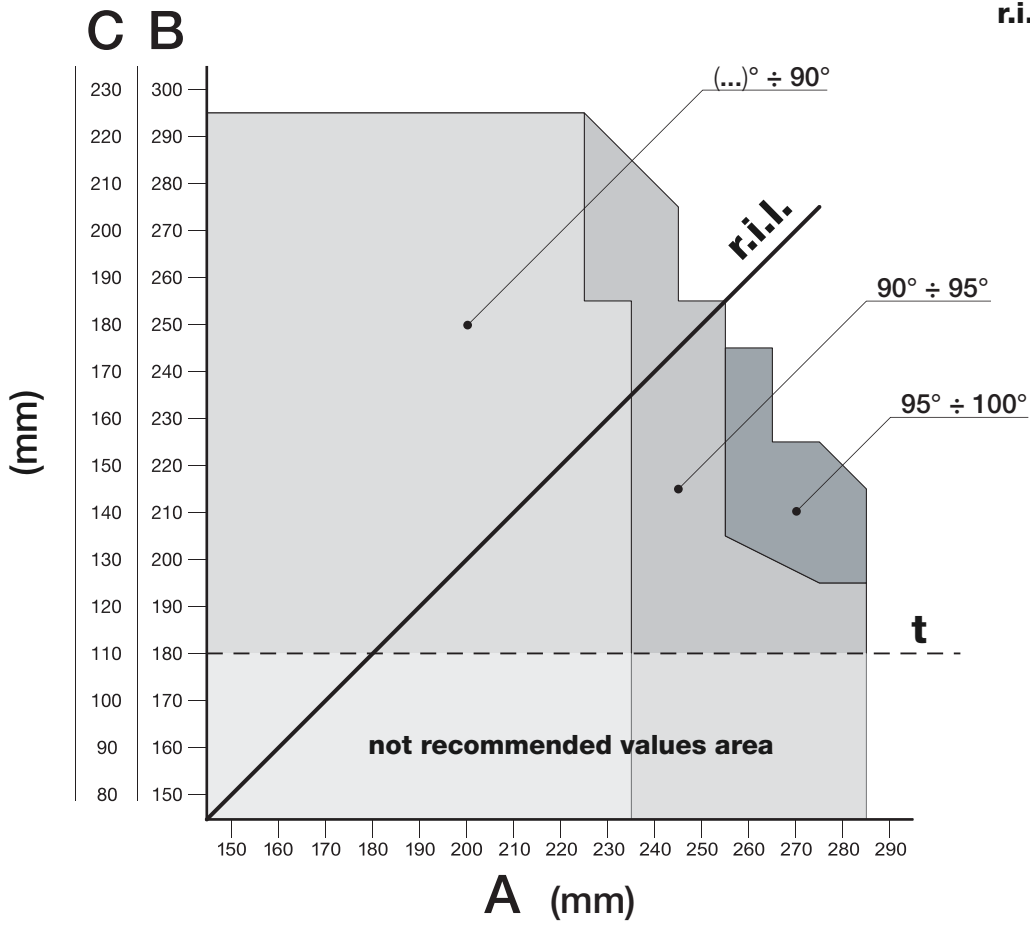

1 Toona 4-5

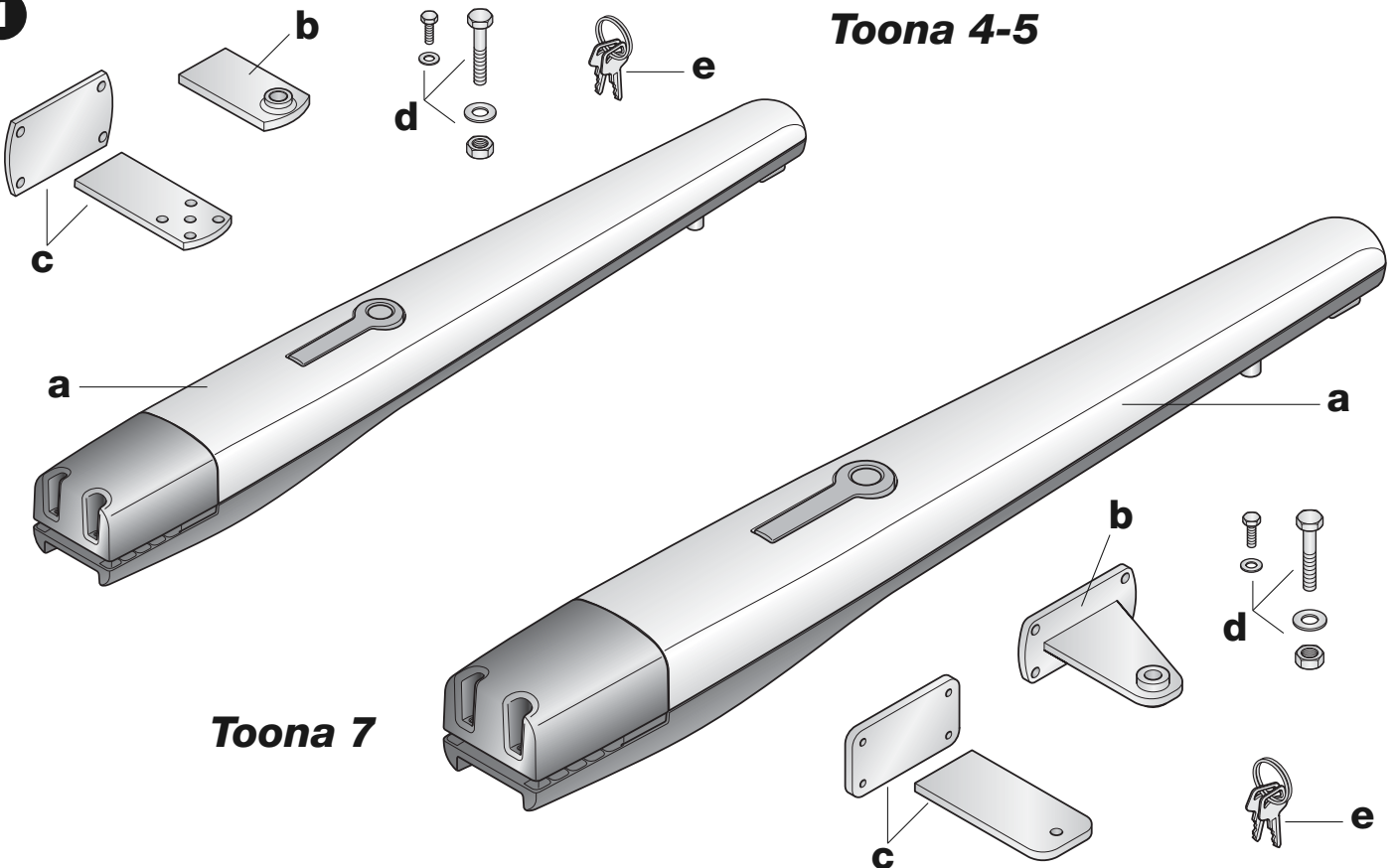

2

Toona 4

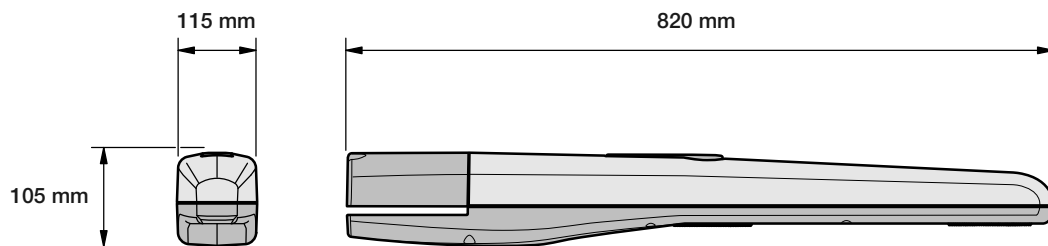

Toona 5

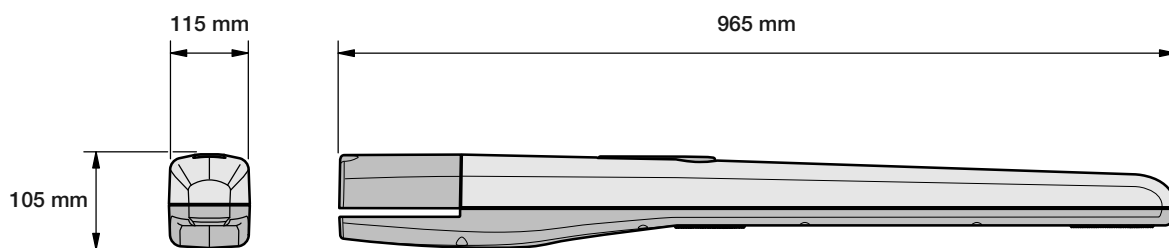

Toona 7

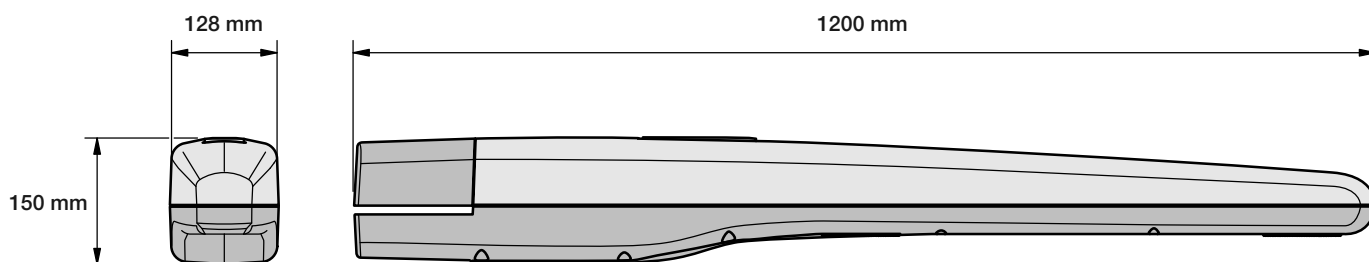

3

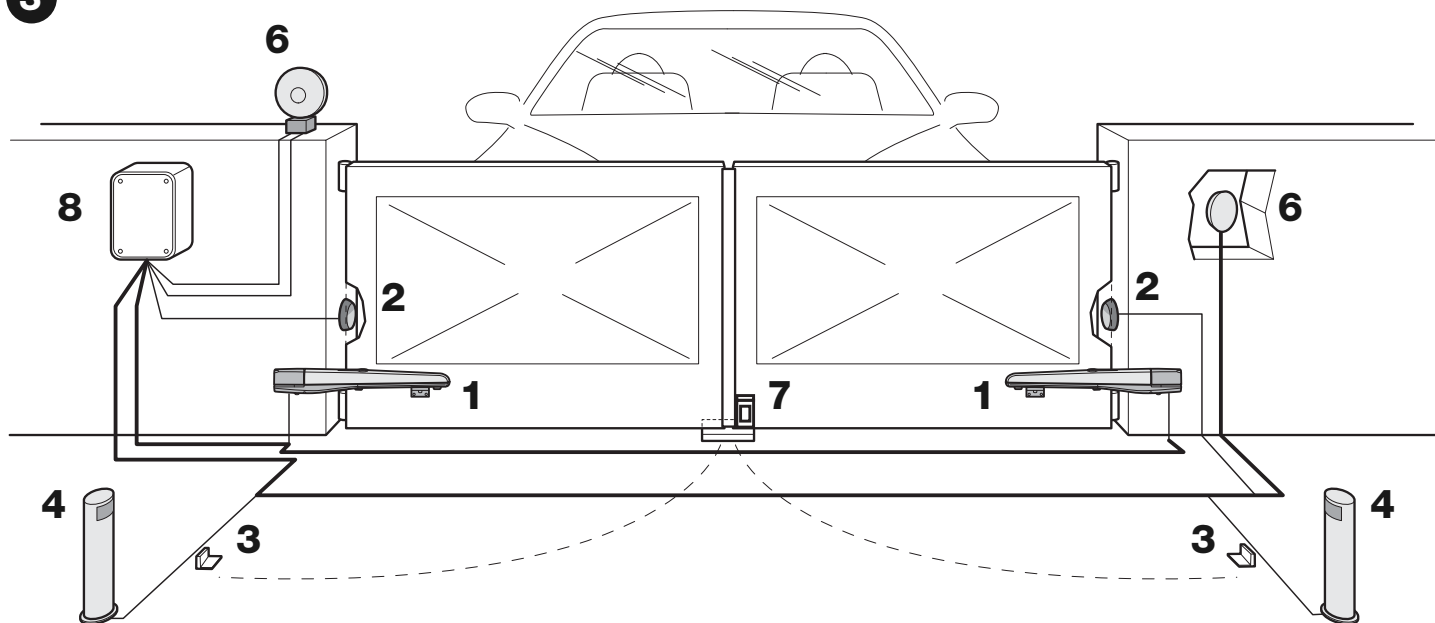

4

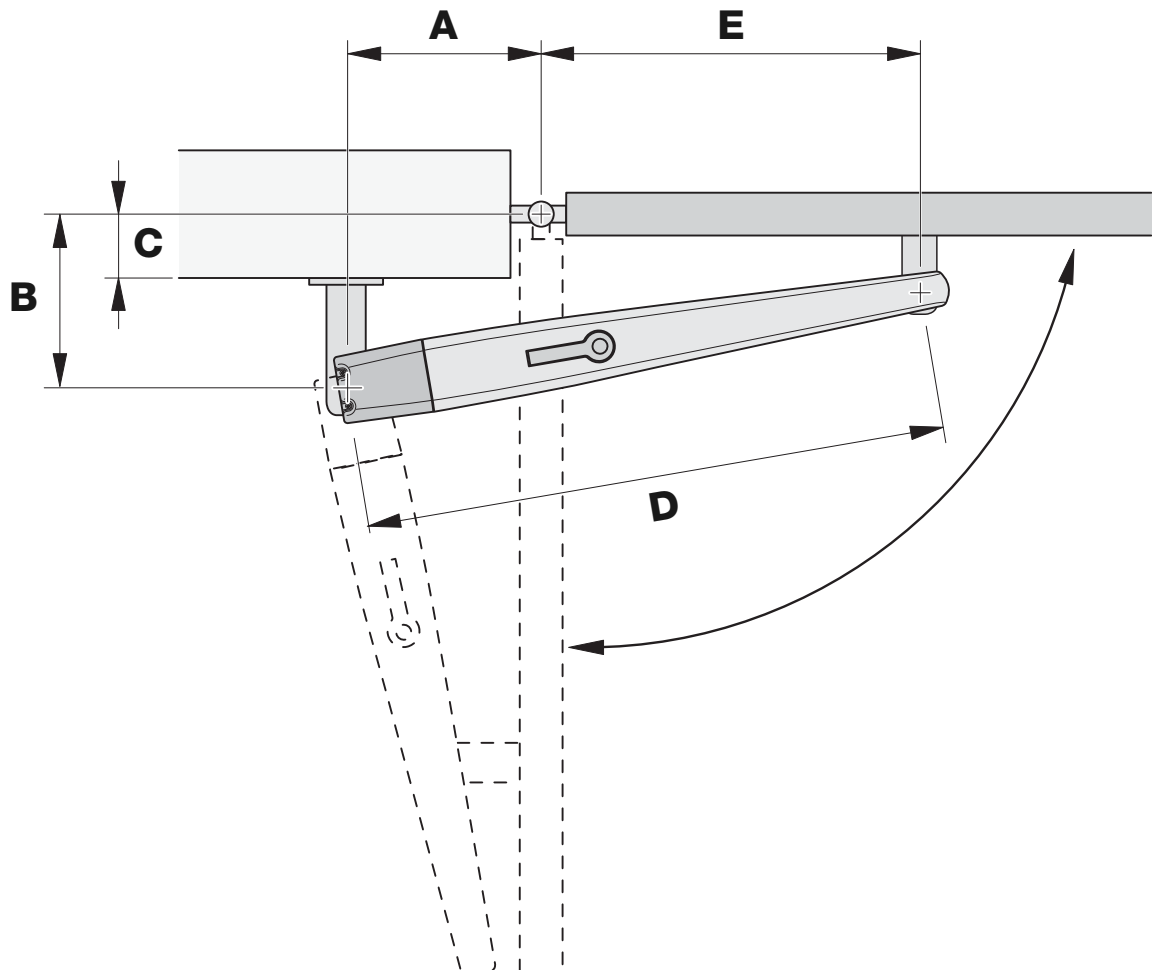

5

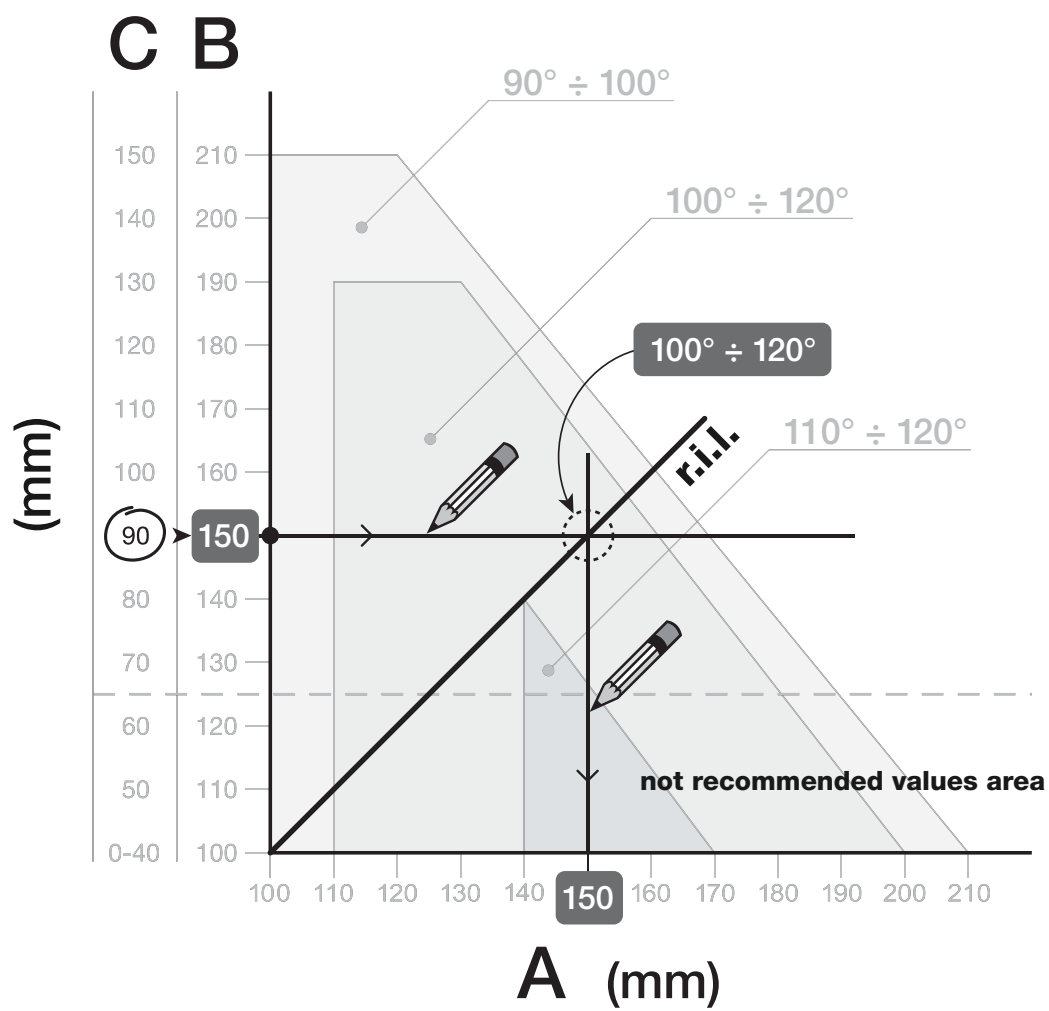

6

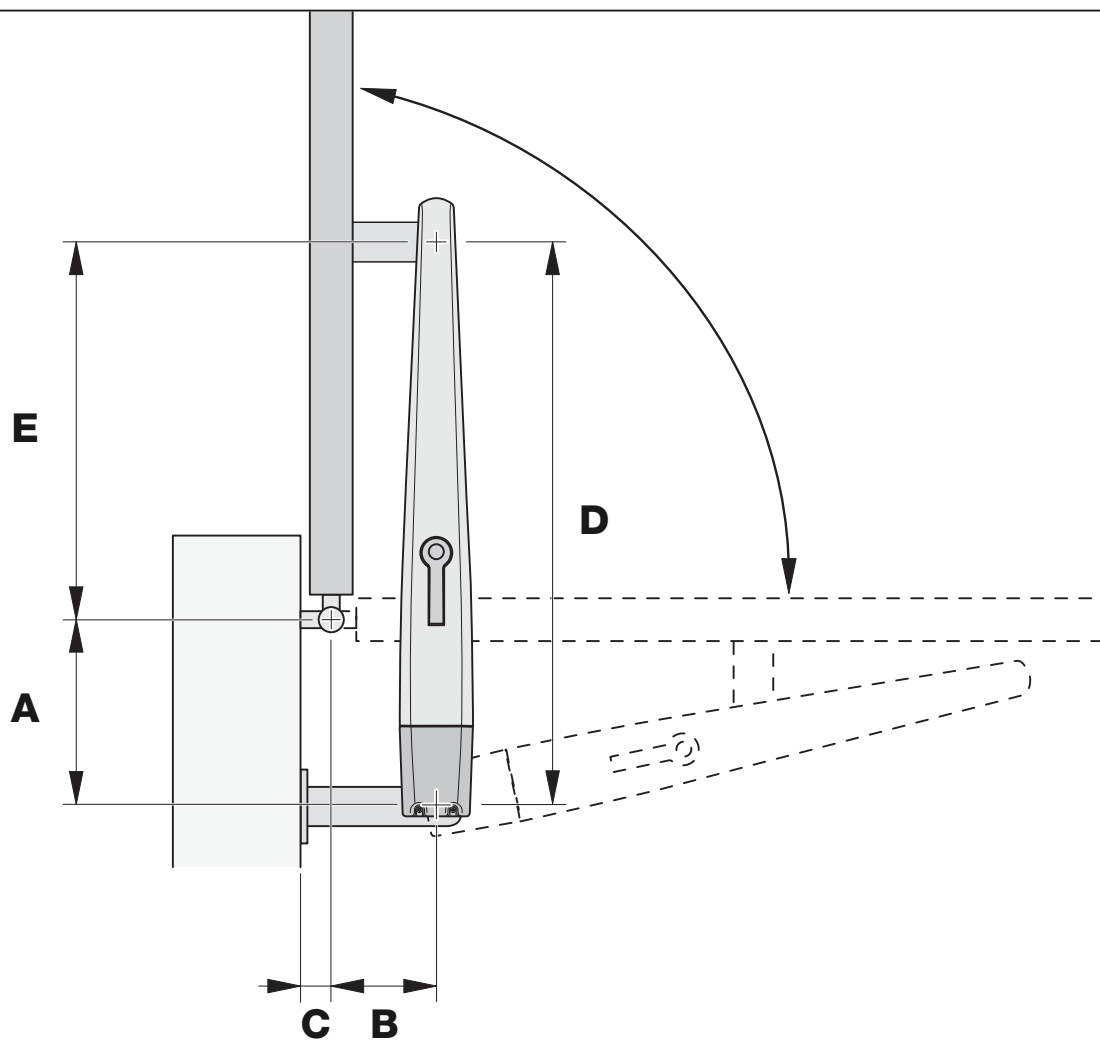

7

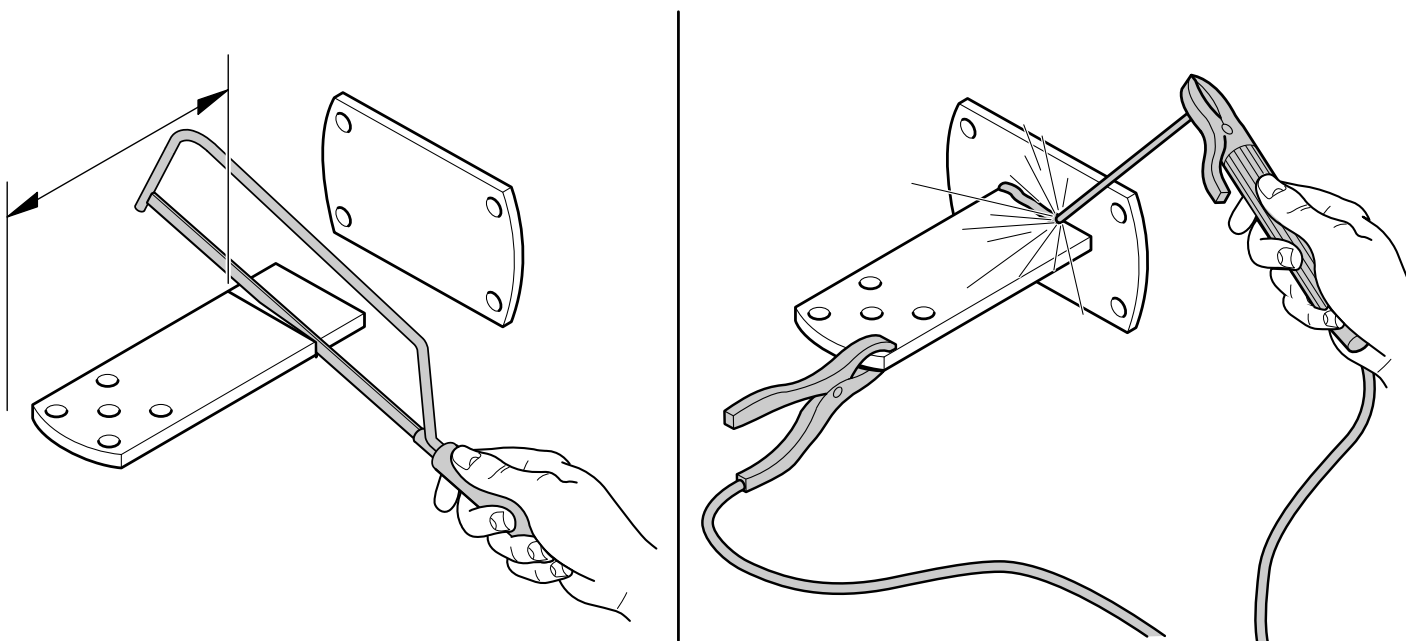

8

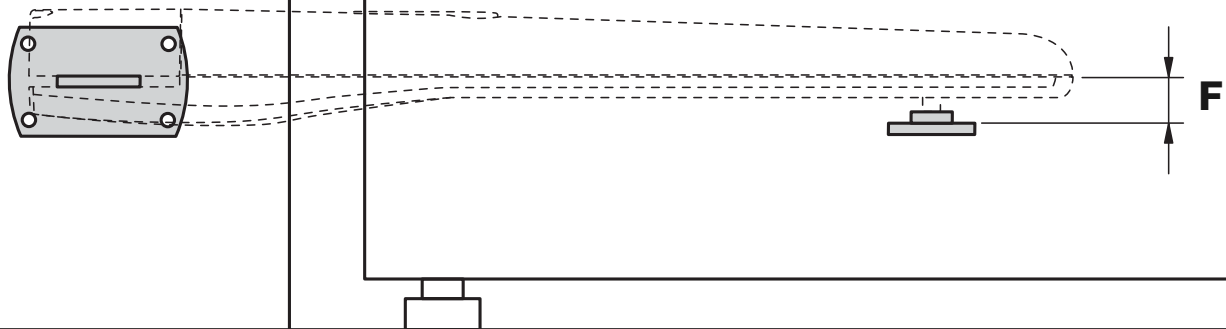

Toona 4-5: $F = 44 \text{ mm}$

Toona 7: $F = 50 \text{ mm}$

9

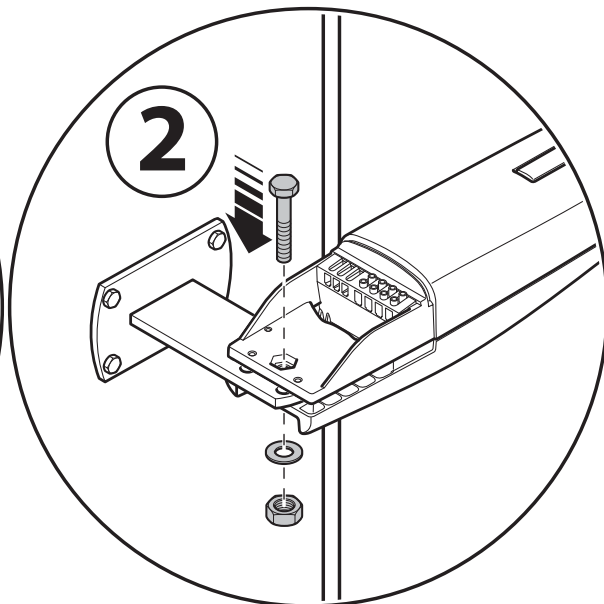
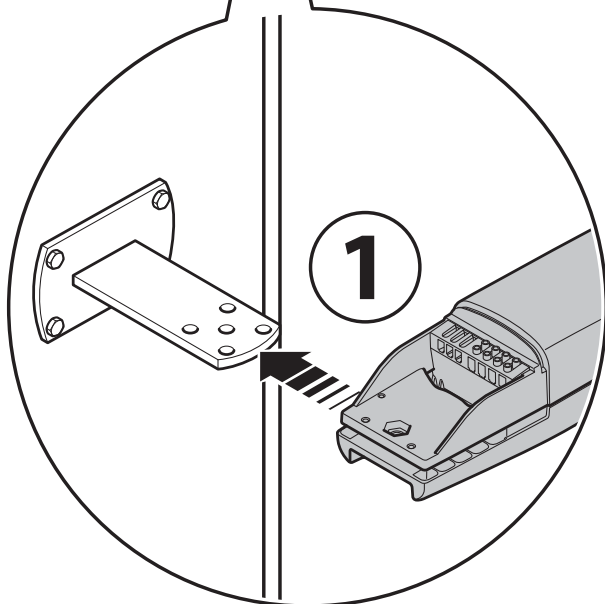
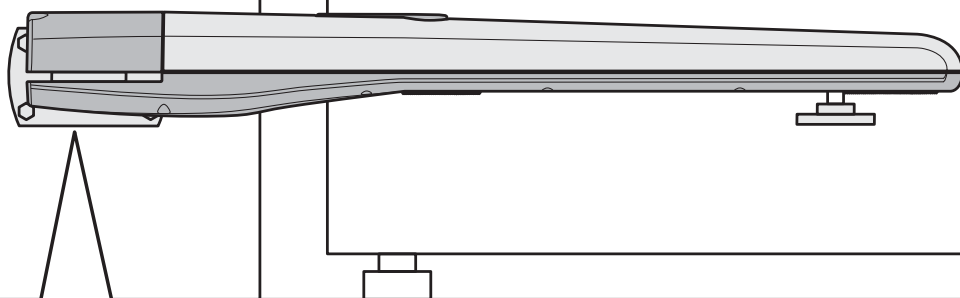

10

Toona 4-5

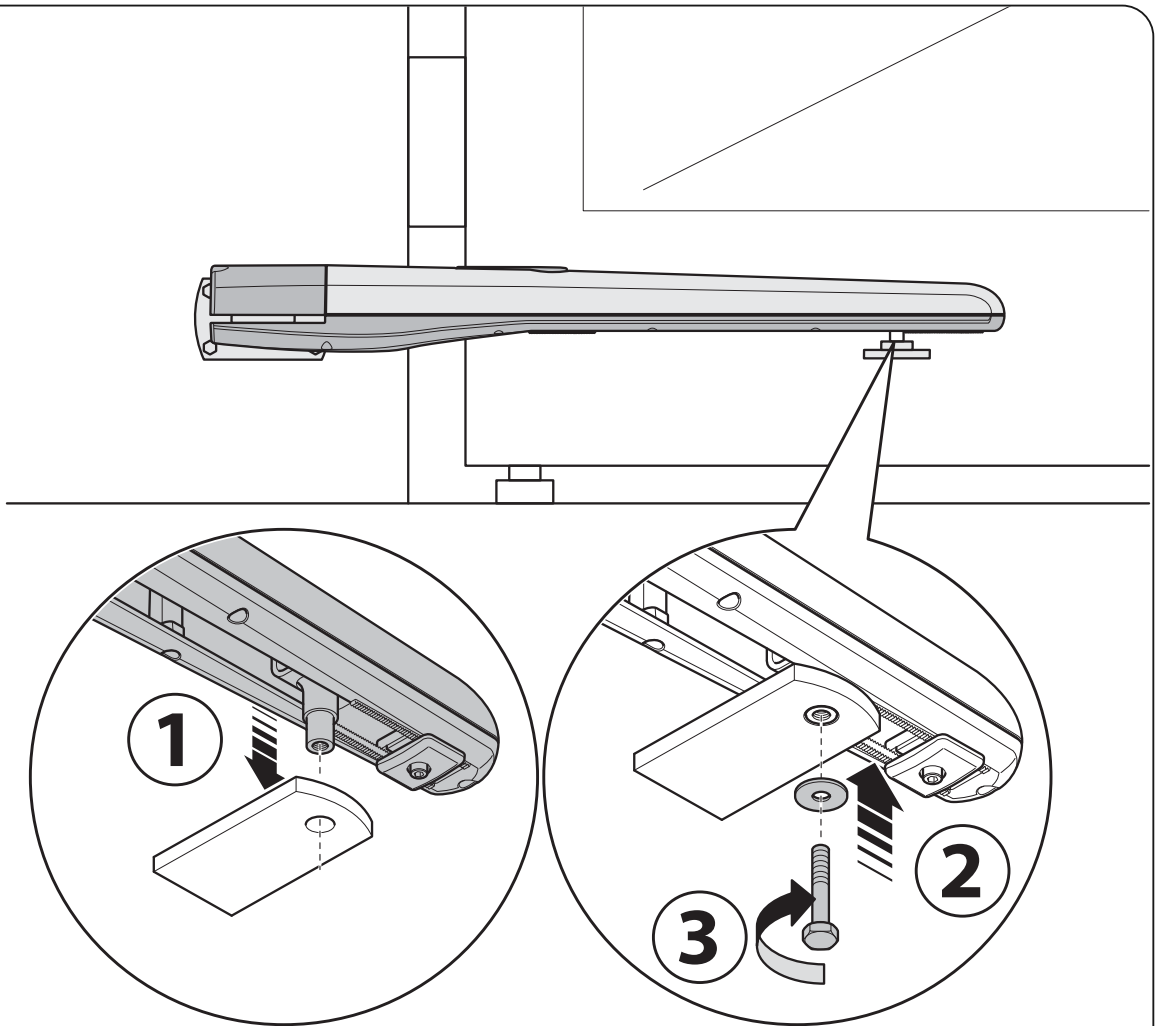

Toona 7

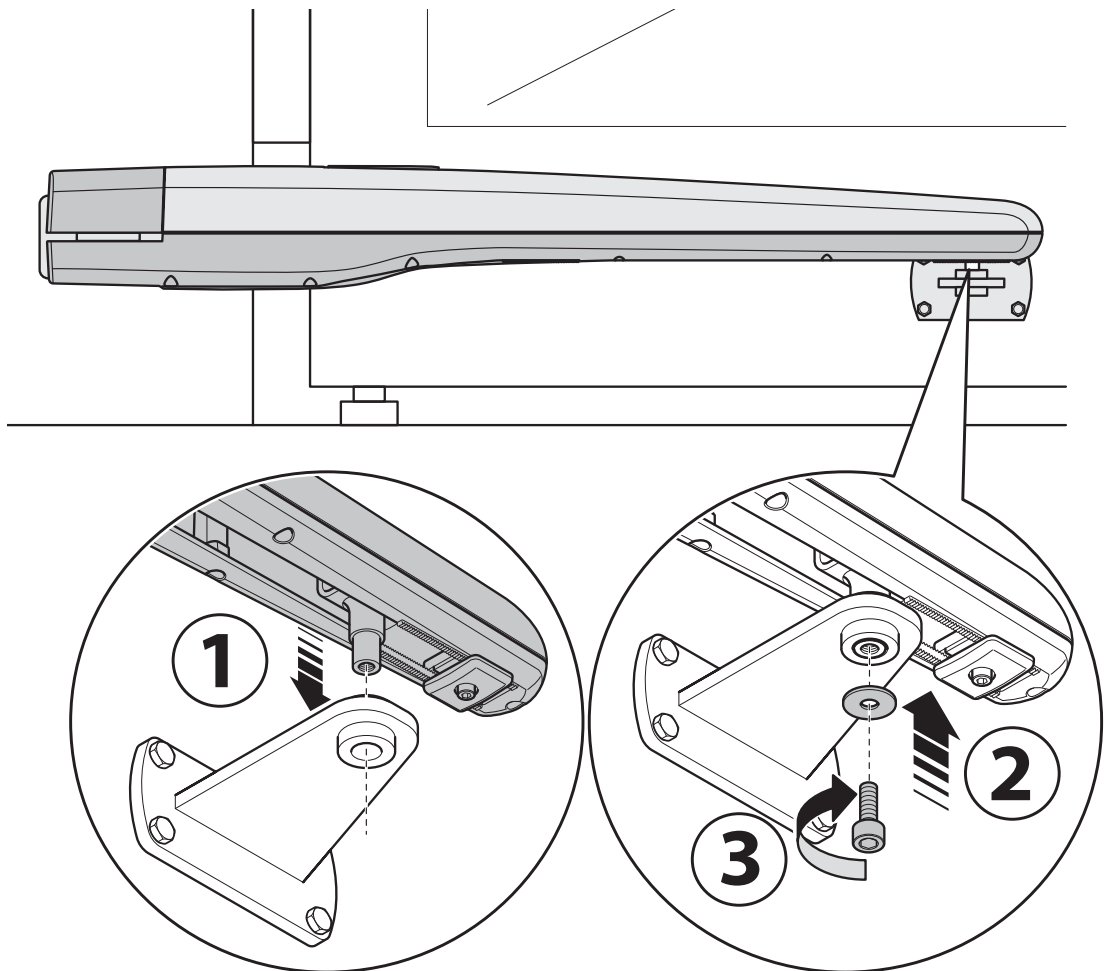

11

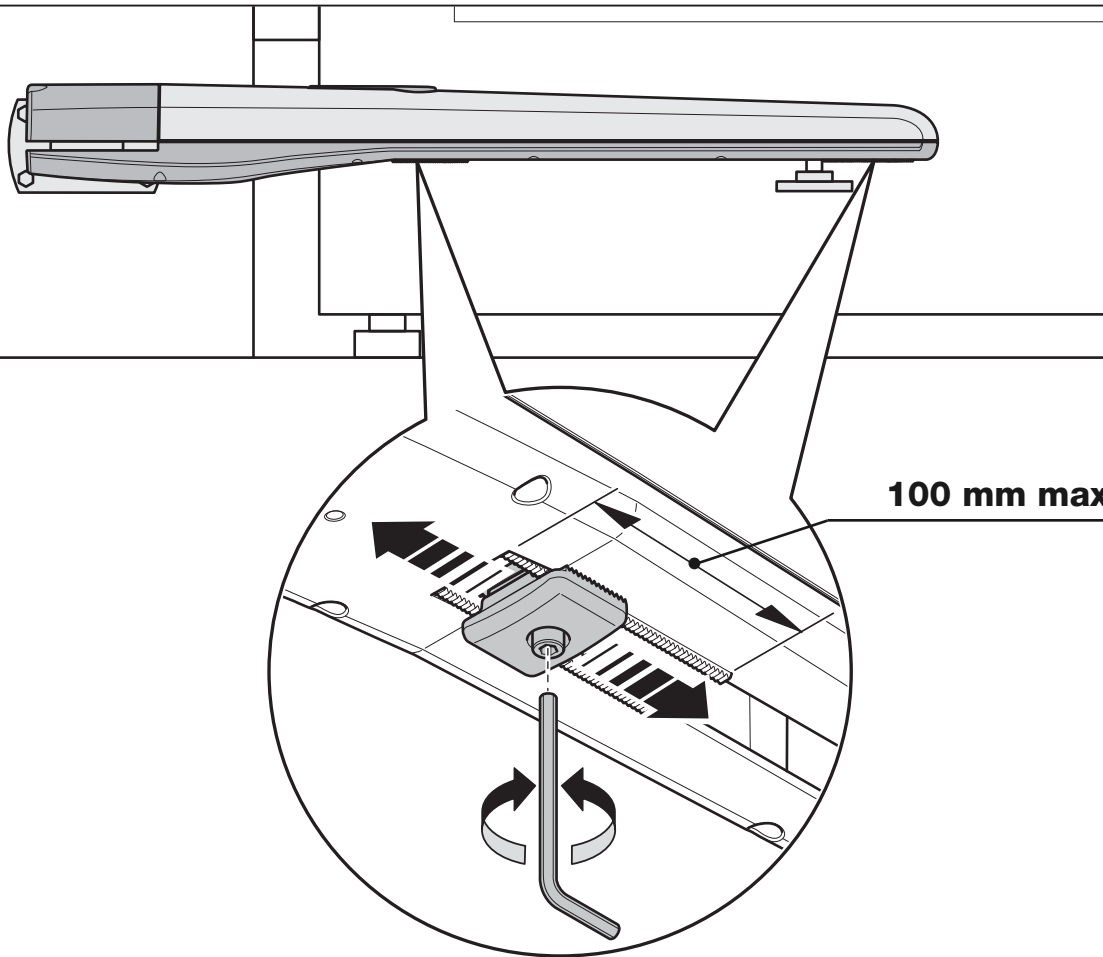

Toona 4-5

12

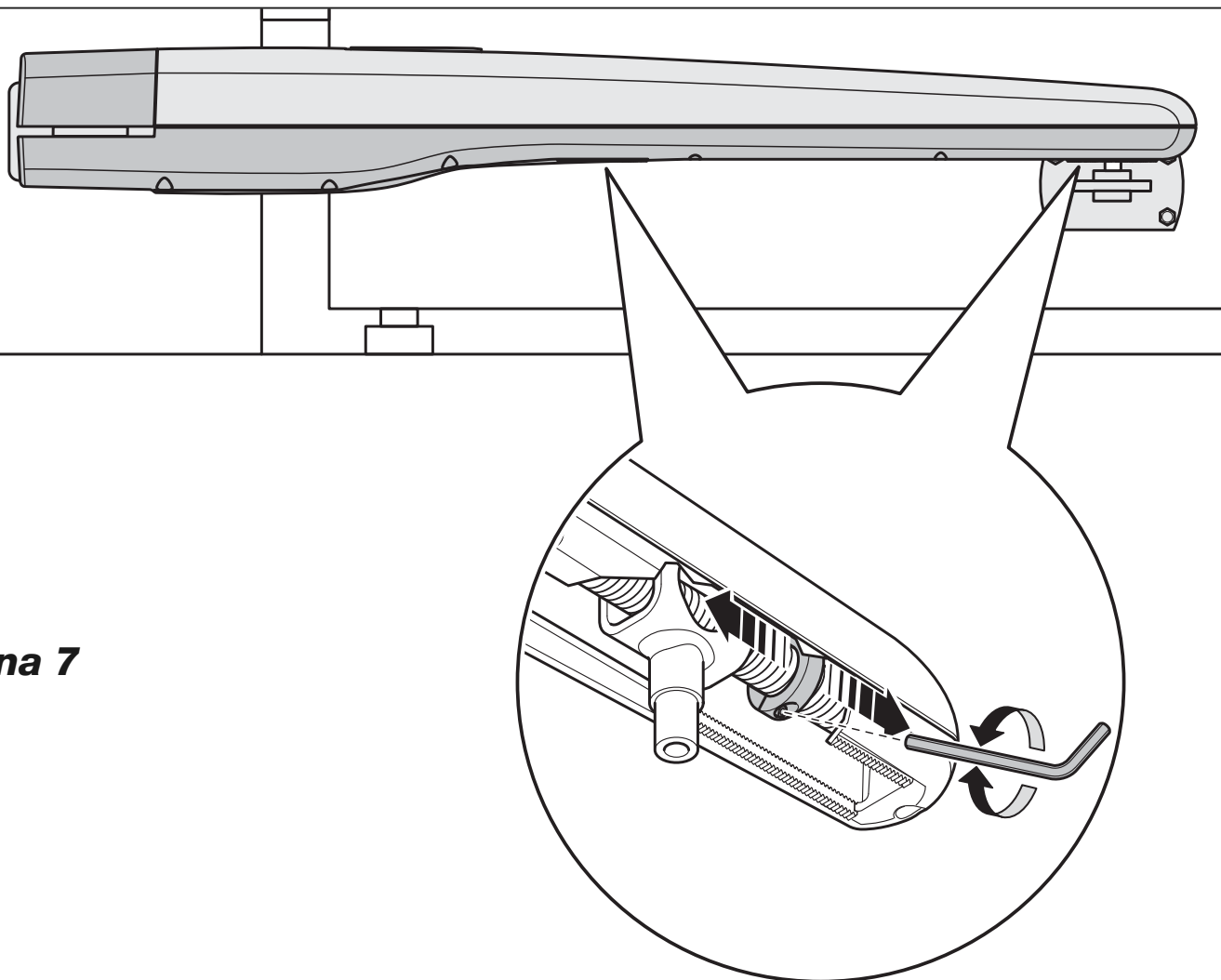

Toona 7

13

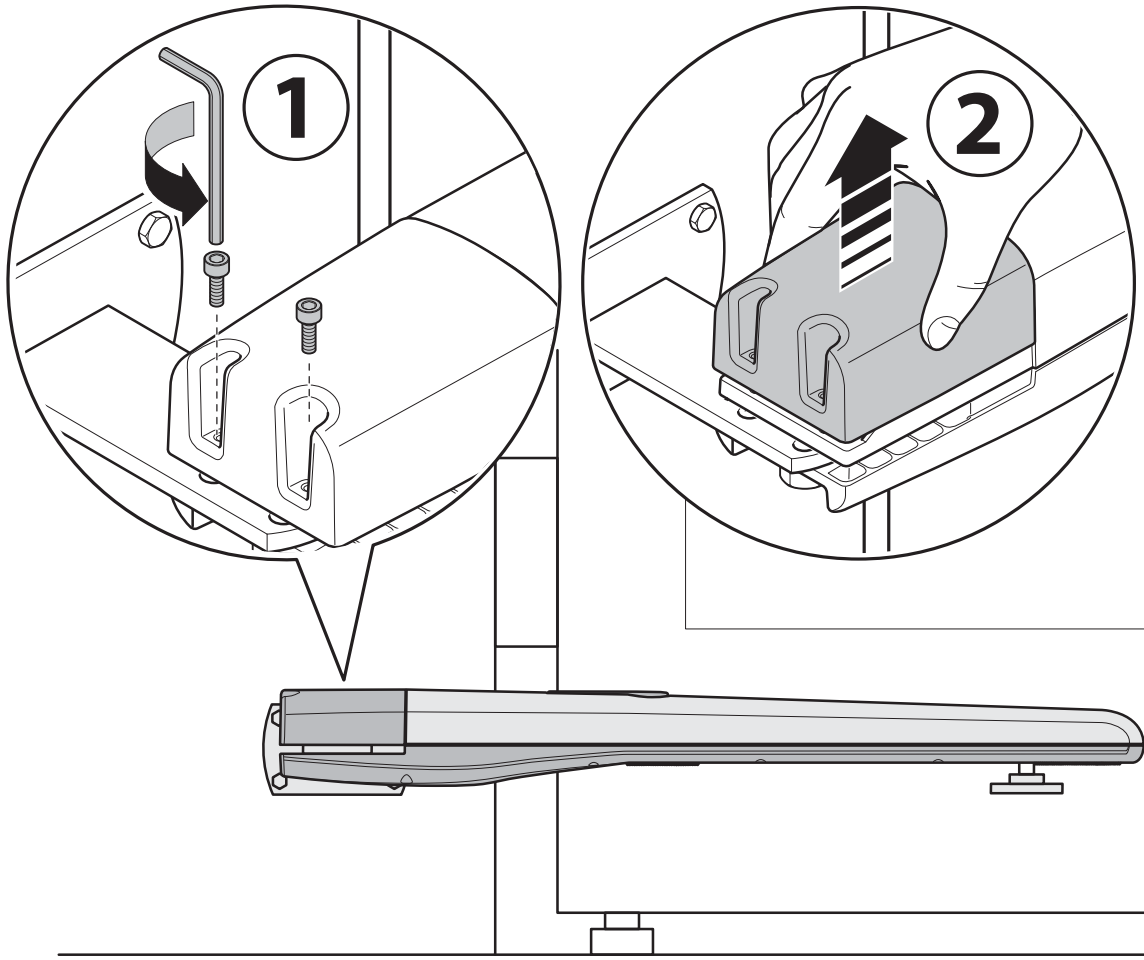

14

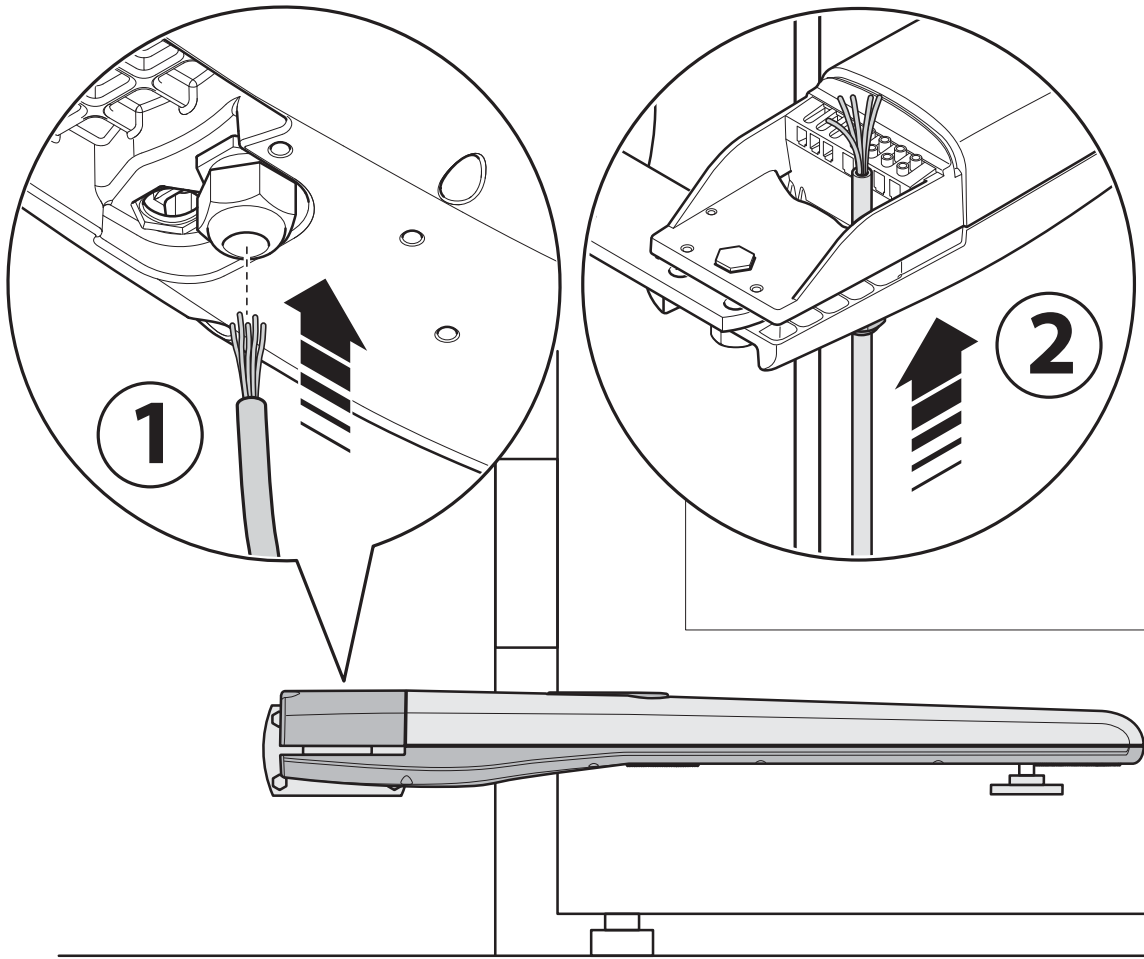

15

Toona 4-5 (24 V)

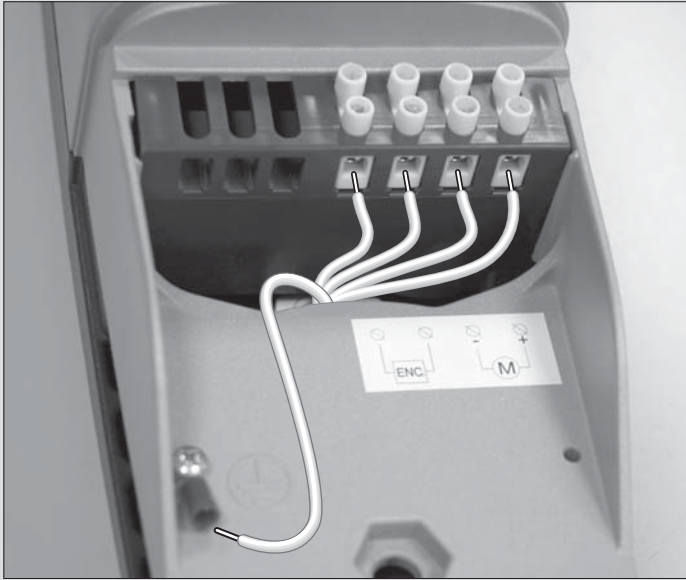

Toona 4-5 (230 V)

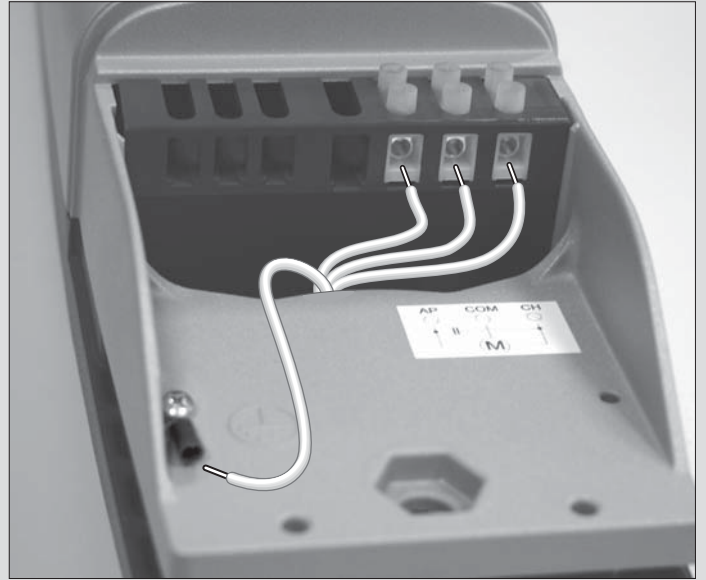

Toona 7 (24 V)

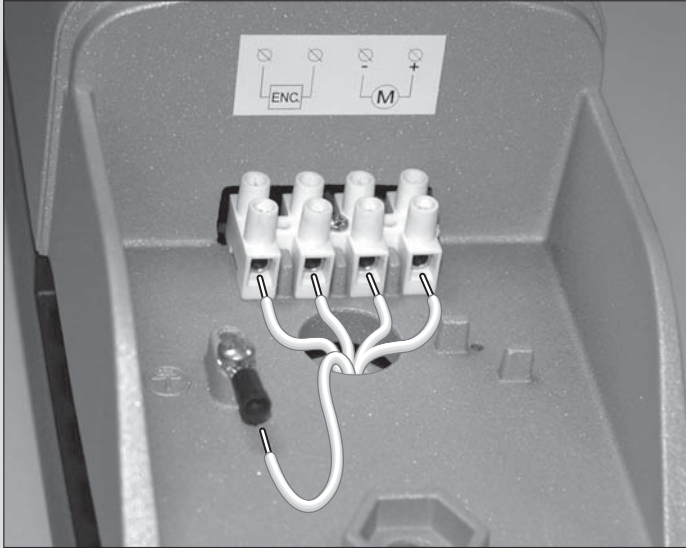

24 V

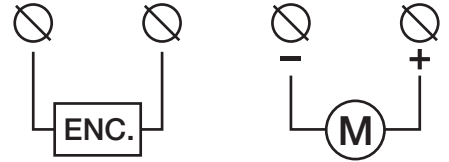

230 V

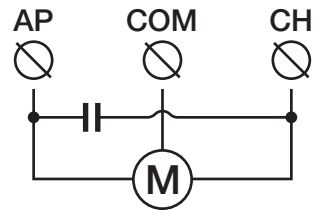

16

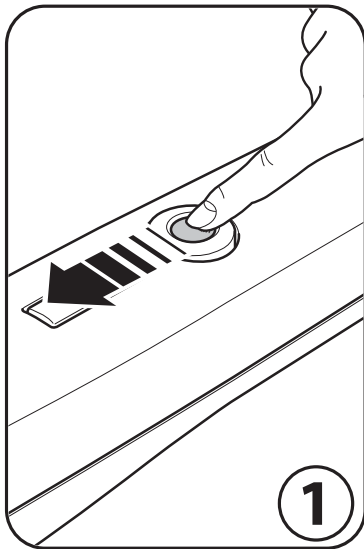

1

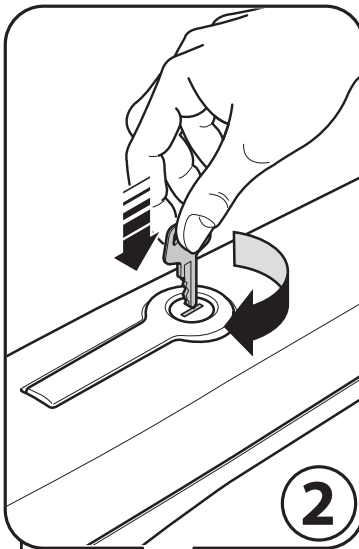

2

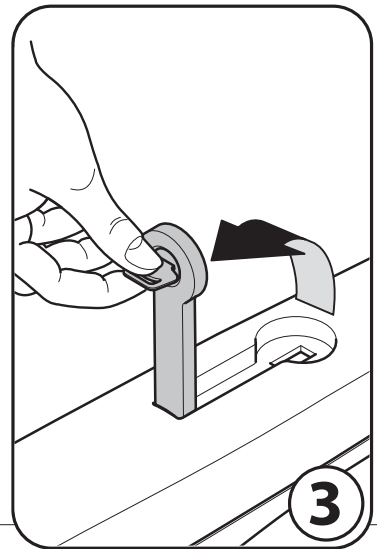

3

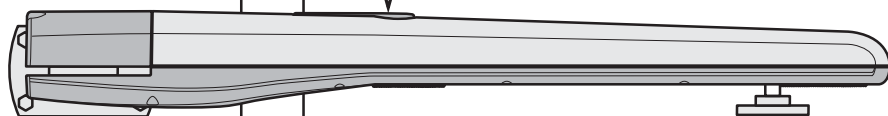



Nice

Headquarters

Nice SpA

Oderzo TV Italia
Ph. +39.0422.85.38.38
Fax +39.0422.85.35.85
info@niceforyou.com

Nice in Italy

Nice Padova

Sarmeola di Rubano PD Italia
Ph. +39.049.89.78.93.2
Fax +39.049.89.73.85.2
infopd@niceforyou.com

Nice Roma

Roma RM Italia
Ph. +39.06.72.67.17.61
Fax +39.06.72.67.55.20
inforoma@niceforyou.com

Nice Worldwide

Nice France

Buchelay France
Ph. +33.(0)1.30.33.95.95
Fax +33.(0)1.30.33.95.96
info@fr.niceforyou.com

Nice France Sud

Aubagne France
Ph. +33.(0)4.42.62.42.52
Fax. +33.(0)4.42.62.42.50
infomarseille@fr.niceforyou.com

Nice France Rhône Alpes

Decines Charpieu France
Ph. +33.(0)4.78.26.56.53
Fax +33.(0)4.78.26.57.53
infoyon@fr.niceforyou.com

Nice Belgium

Leuven (Heverlee) Belgium
Ph. +32.(0)16.38.69.00
Fax +32.(0)16.38.69.01
info@be.niceforyou.com

Nice Deutschland

Gelnhausen Deutschland
Ph. +49.(0)6051.91.520
Fax +49.(0)6051.91.52.119
info@de.niceforyou.com

Nice España Madrid

Mostoles Madrid España
Ph. +34.(0)9.16.16.33.00
Fax +34.(0)9.16.16.30.10
info@es.niceforyou.com

Nice España Barcelona

Sant Quirze del Valles
Barcelona España
Ph. +34.(0)9.37.84.77.75
Fax +34.(0)9.37.84.77.72
info@es.niceforyou.com

Nice Polska

Pruszków Polska
Ph. +48.(022).759.40.00
Fax +48.(022).759.40.22
info@pl.niceforyou.com

Nice Portugal

Mem Martins Portugal
Ph. +351.21.922.82.10
Fax +351.21.922.82.19
info@pt.niceforyou.com

Nice Romania

Cluj Napoca Romania
Ph./Fax +40.(0)264.453.127
info@ro.niceforyou.com

Nice Turkey

Kadikoy Istanbul Turkey
Ph. +90.216.456.34.97
Fax +90.216.455.78.29
info@tr.niceforyou.com

Nice UK

Sutton in Ashfield
United Kingdom
Ph. +44.16.23.55.80.86
Fax +44.16.23.55.05.49
info@uk.niceforyou.com

Nice Australia

Wetherill Park Australia
Ph. +61.(0)2.96.04.25.70
Fax +61.(0)2.96.04.25.73
info@au.niceforyou.com

Nice China

Shanghai P. R. China
Ph. +86.21.575.701.46/45
Fax +86.21.575.701.44
info@cn.niceforyou.com

Nice USA

Jacksonville Florida USA
Ph. +1.904.786.7133
Fax +1.904.786.7640
info@us.niceforyou.com